

«O'zbekiston temir yo'llari» DATK

Toshkent temir yo'l muhandislari instituti

EGRI CHIZIQLARNI BATAFSIL REJALASH

5340200 – Bino va inshootlar qurilishi; 5340200 – Bino va inshootlar qurilishi (temir yo'l transportida); 5340400 – Muhandislik kommunikatsiyalari qurilishi va montaji (temir yo'l transportida); 5340600 – Transport inshootlari ekspluatatsiyasi (temir yo'l transportida); 5111000 – Kasb ta'limi (5340600 – Transport inshootlari ekspluatatsiyasi); 5111000 – Kasb ta'limi (5340200– Bino va inshootlar qurilishi) ta'lim yo'nalishlari 2-bosqich bakalavriat talabalari uchun yozgi geodezik amaliyotni o'tashga doir uslubiy ko'rsatmalar

UDK 584.6

Mazkur uslubiy ko'rsatma Qurilish fakulteti talabalarining o'quv-geodezik amaliyotida "Egri chiziqlarni batafsil rejalash" ishlarini bajarishi uchun mo'ljallangan.

Uslubiy ko'rsatmada doiraviy va o'tish egri chiziqlar elementlarini, bosh nuqtalarini piket o'rnini hisoblash yo'llari, batafsil rejalash, hamda piketlarni egri chiziqqa ko'chirish usullari keltirilgan.

Tuzuvchilar: H.T.Qayumova – katta o'qit.;
U.K.Abduraimov – ass.

Taqrizchilar: S.S.Niyazbekov – t.f.n., dot.;
S.A.Toshpulatov – t.f.n., dot., (TAQI)

I. Egri chiziqlarni rejalash

Turli chizg'iy inshootlarni trassalashda va qurishda inshootning asosiy o'qini joy sharoitlari (tafsilot va reliefi) yoki boshqa sabablarga ko'ra ma'lum burchakga o'ng tomonga ($\theta_{o'ng}$) yoki chap tomonga (θ_{chap}) burishga to'g'ri keladi. Bunday burilish joylarda chizg'iy inshoot doiraviy egri chiziq bo'yicha joylashtiriladi, temir yo'llarni qurishda esa doiraviy egri chiziqlar hamda o'tish egri chiziqlari qo'llaniladi.

Inshootning loyihaviy o'qini joyda belgilash geodezik o'lchashlar yordamida amalga oshiriladi. Bunda, dastlab, egri chiziq (ECh) ning bosh nuqtalari: boshi, o'rtasi va ohiri joyda belgilanadi. So'ng batafsil rejalaniadi. Egri chiziqni joyda rejalash uchun avval uning elementlari hisoblanadi.

II. Doiraviy egri chiziq elementlari

Agar egri chiziq radiusi doimiy o'zgarmas bo'lsa, u doiraviy egri chiziq deb nomlanadi. Doiraviy egri chiziqning bosh nuqtalari: egri chiziq boshi (EB), egri chiziq o'rtasi (EO') va egri chiziq oxiri (EO) larni joyda belgilash (rejalash) uchun uning quyidagi elementlarini aniqlash kerak (1-rasm):

- 1) burilish burchagi - θ ;
- 2) egri chiziq radiusi - R ;
- 3) egri chiziq tangensi - T ;
- 4) egri chiziq uzunligi - K ;
- 5) egri chiziq bissektrisasi - B ;
- 6) egri chiziq domeri - D .

Burilish burchagi θ trassani piketlash jarayonida teodolit yordamida o'lchangan trassaning ichki burchagi β orqali aniqlanadi. Agar trassa o'ng tomonga burilsa, $\theta_{o'ng} = 180^\circ - \beta$; agar chap tomonga burilsa, $\theta_{chap} = \beta - 180^\circ$ formulalardan topiladi (2-rasm).

Egri chiziq radiusi texnik talablarga ko'ra tanlab olinadi yoki belgilanadi. Qolgan elementlar quyidagi formulalar bo'yicha hisoblanadi:

$$T = R \tan \frac{\theta}{2};$$
$$K = \frac{\pi R \theta}{180^\circ};$$
$$B = R \left(\sec \frac{\theta}{2} - 1 \right);$$
$$D = 2T - K.$$

Ish jarayonida bu elementlarning qiymati egri chiziqni burilish burchagi θ va radiusi R orqali mahsus “Doyraviy egri chiziqlarni rejalash” jadvalidan olinadi.

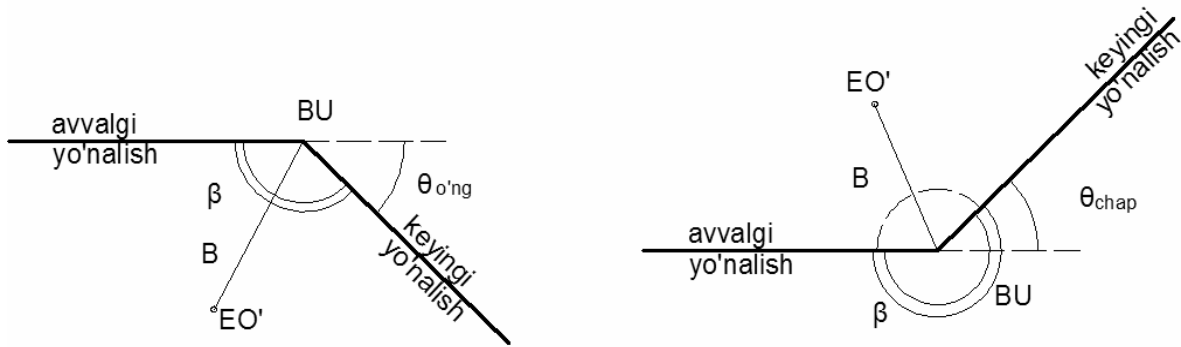
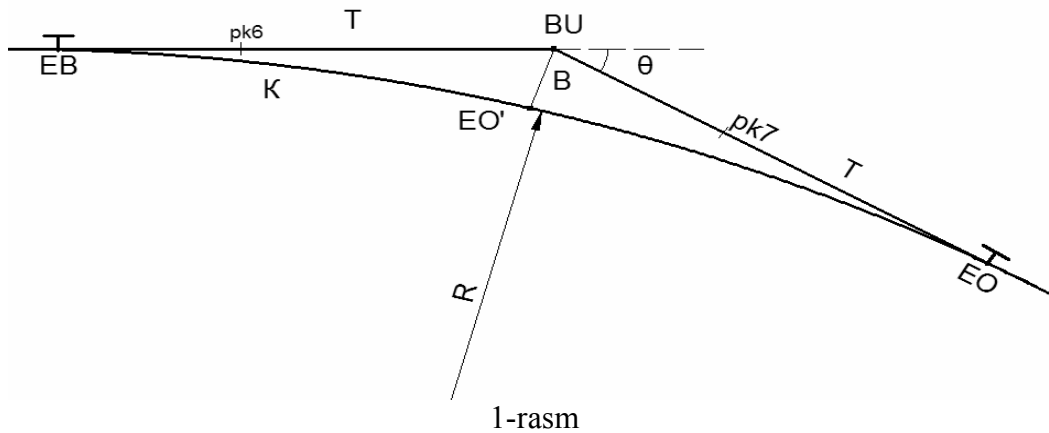

2-rasm

Ushbu uslubiy ko'rsatmalarda keltirilgan 1-jadvaldan quyidagicha foydalaniladi.

Masalan, berilgan: $\theta = 28^{\circ}34'$, $R = 400\text{m}$.

Jadvalning $\theta=28^{\circ}$ deb ko'rsatilgan 42- va 43-betlarini ochamiz va betning o'rtasida yo'g'on shrift bilan yozilgan minutlar ustunida $34'$ li qatorni topamiz. Shu $34'$ qatoridan $T = 254,59\text{m}$; $K = 498,58\text{m}$; $D = 10,59\text{m}$; $B = 31,90\text{m}$ olamiz. Agar bu misoldagi kabi elementlar qiymatining butun qismi berilgan bo'lmasa, u qatorning yuqoridagisidan olinadi (masalan, T uchun butun son - 254, K uchun - 498 ga teng va h.k.)

Bundan tashqari, jadvaldagi elementlar qiymati $R=1000\text{m}$ uchun hisoblangan va ularni ishlanayotgan egri chiziq radiusi bo'yicha qayta hisoblash kerak, ya'ni:

$$T = 254,59 \cdot 400\text{m} : 1000\text{m} = 254,59 \cdot 0,4 = 101,84\text{m};$$

$$K = 498,58 \cdot 0,4 = 199,43\text{m};$$

$$D = 10,59 \cdot 0,4 = 4,24\text{m};$$

$$B = 31,90 \cdot 0,4 = 12,76\text{m}.$$

$\theta - 14^\circ$				R=1000	$\theta - 15^\circ$			
Doyraviy egri chiziq asosiy elementlari				θ burchagi minutlari	Doyraviy egri chiziq asosiy elementlari			
T	K	D	B		T	K	D	B
122,78	244,35	1,22	7,51	0	131,65	261,80	1,51	8,63
93	64	23	53	1	80	262,09	51	65
123,08	93	23	55	2	95	38	52	67
123,23	245,22	1,24	7,56	3	132,1	262,67	1,52	8,69
38	51	24	58	4	24	96	53	71
52	80	25	60	5	39	263,25	53	73
123,67	246,09	1,25	7,62	6	132,54	263,54	1,54	8,75
82	38	25	64	7	69	84	54	76
97	67	26	65	8	84	264,13	55	78
124,11	246,96	1,26	7,67	9	132,98	264,42	1,55	8,80
26	247,2	27	69	10	133,13	71	56	82
41	55	27	71	11	28	265,00	56	84
124,56	247,84	1,28	7,73	12	133,43	265,29	1,57	8,86
70	248,13	28	75	13	58	58	57	88
80	42	29	76	14	72	87	58	90
125,00	248,71	1,29	7,78	15	133,87	266,16	1,58	8,92
15	249,00	29	80	16	134,02	45	59	94
30	29	30	82	17	17	74	59	96
125,44	249,58	1,30	7,84	18	134,32	267,04	1,60	8,98
59	87	31	86	19	46	33	60	9,00
74	250,16	31	87	20	61	62	61	02
125,89	250,45	1,32	7,89	21	134,76	267,91	1,61	9,04
126,03	75	32	91	22	91	268,20	62	06
18	251,04	33	93	23	135,06	49	62	08
126,33	251,33	1,33	7,95	24	135,21	268,78	1,63	9,10
48	62	34	97	25	35	269,07	63	12
62	91	34	99	26	50	36	64	14
126,77	252,20	1,35	8,00	27	135,65	269,65	1,65	9,16
92	49	35	02	28	80	94	65	18
127,07	78	35	04	29	95	270,24	66	20
127,22	253,07	1,36	8,06	30	136,09	270,53	1,66	9,22

$\theta - 14^\circ$

R=1000

 $\theta - 15^\circ$

Doyraviy egri chiziq asosiy elementlari				θ burchagi minutlari	Doyraviy egri chiziq asosiy elementlari			
T	K	D	B		T	K	D	B
127,22	253,07	1,36	8,06	30	136,09	27053	1,66	9,22
36	36	36	08	31	24	82	67	24
51	65	37	10	32	39	271,11	67	26
127,66	253,95	1,37	8,12	33	136,54	271,40	1,68	9,28
81	254,24	38	13	34	69	69	68	30
96	53	38	15	35	83	98	69	32
128,10	254,82	1,39	8,17	36	136,98	272,27	1,69	9,34
25	255,11	39	19	37	137,13	56	70	36
40	40	40	21	38	28	85	71	38
128,55	255,69	1,40	8,23	39	137,43	273,14	1,71	9,40
69	98	41	25	40	58	43	72	42
84	256,27	41	27	41	72	73	72	44
128,99	256,56	1,42	8,28	42	137,87	274,02	1,73	9,46
129,14	85	42	30	43	138,02	31	73	48
29	257,15	43	32	44	17	60	74	50
129,43	257,44	1,43	8,34'	45	138,32	274,89	1,74	9,52
58	73	44	36	46	46	275,18	75	54
73	258,02	44	38	47	61	47	76	56
129,88	258,31	1,45	8,40	48	138,76	276,76	1,76	9,58
130,03	60	45	42	49	91	276,05	77	60
17	89	46	44	50	139,06	34	77	62
130,32	259,18	1,46	8,46	51	139,21	276,63	1,78	9,64
47	47	47	48	52	35	93	78	66
62	76	47	49	53	60	277,22	79	68
130,76	260,05	1,48	8,51	54	139,65	277,51	1,79	9,70
91	34	48	53	55	80	80	80	72
131,06	64	49	55	56	95	278,09	81	75
131,21	260,93	1,49	8,57	57	140,10	278,38	1,81	9,77
36	261,22	50	59	58	24	67	82	79
50	51	50	61	59	39	96	82	81
131,65	261,80	1,51	8,63	60	140,54	279,25	1,83	9,83

$\theta - 16^\circ$				$R=1000$	$\theta - 17^\circ$			
Doyraviy egri chiziq asosiy elementlari				θ burchagi minutlari	Doyraviy egri chiziq asosiy elementlari			
T	K	D	B		T	K	D	B
140,54	279,25	1,83	9,83	0	149,45	296,71	2,20	11,11
69	54	83	85	1	60	297,00	20	13
84	83	84	87	2	75	29	21	15
140,99	280,13	1,85	9,89	3	149,90	297,58	2,22	11,17
141,13	42	85	91	4	150,05	87	22	19
28	71	86	93	5	19	298,16	23	22
141,43	281,00	1,86	9,95	6	150,34	298,45	2,24	11,24
58	29	87	97	7	49	74	24	26
73	58	88	99	8	64	299,03	25	28
141,88	281,87	1,88	10,01	9	150,79	299,32	2,26	11,30
142,02	282,16	89	04	10	94	61	27	33
17	45	89	06	11	151,09	91	27	35
142,32	282,74	1,90	10,08	12	151,24	300,20	2,27	11,37
47	283,03	90	10	13	38;	49	28	39
62	33	91	12	14	53	78	29	42
142,77	283,62	1,92	10,14	15	151,68	301,07	2,29	11,44
91	91	92	16	16	83	36	30	46
143,06	284,20	93	18	17	98	65	31	48
143,21	284,49	1,93	10,20	18	152,13	301,94	2,32	11,51
36	78	94	22	19	28	302,23	32	53
51	285,07	95	24	20	43	52	33	55
143,66	285,36	1,95	10,27	21	152,57	302,81	2,34	11,57
81	65	96	29	22	72	303,11	34	60
95	94	96	31	23	87	40	35	62
144,10	286,23	1,97	10,33	24	153,02	303,69	2,36	11,64
25	52	98	35	25	17	98	36	66
40	82	98	37	26	32	304,27	37	69
144,55	287,11	1,99	10,39	27	153,47	303,56	2,38	11,71
70	40	99	41	28	62	85	38	73
84	69	99	44	29	77	305,14	39	75
144,99	287,98	2,00	10,46	30	153,91	305,43	2,40	11,78

$\theta - 16^\circ$				$R=1000$	$\theta - 17^\circ$			
Doyraviy egri chiziq asosiy elementlari				θ burchagi minutlari	Doyraviy egri chiziq asosiy elementlari			
T	K	D	B		T	K	D	B
144,99	287,98	2,00	10,46	30	153,91	305,43	2,40	11,78
145,14	288,27	01	48	31	154,06	72	40	80
29	56	02	50	32	21	306,01	41	82
145,44	288,85	2,03	10,52	33	154,36	306,31	2,42	11,84
59	289,14	03	54	34	51	60	42	87
74	43	04	56	35	66	89	43	89
145,88	289,72	2,04	10,59	36	154,81	307,18	2,44	11,91
146,03	290,02	05	61	37	96	47	45	93
18	31	06	63	38	55,11	76	45	96
146,33	290,60	2,06	10,65	39	155,25	308,05	2,46	11,98
48	89	07	67	40	40	34	47	12,00
63	291,18	07	69	41	55	63	47	03
146,78	291,47	2,08	10,71	42	155,70	308,92	2,48	12,05
92	76	09	74	43	85	309,21	49	07
147,07	292,05	09	76	44	156,00	51	49	09
147,22	292,34	2,10	10,78	45	136,15	309,80	2,50	12,12
37	63	11	80	46	30	310,09	51	14
52	92	11	82	47	45	38	52	16
147,67	293,22	2,12	10,84	48	156,60	310,67	2,52	12,19
82	51	13	87	40	74	96	53	21
96	80	13	89	50	89	311,25	54	23
148,11	294,09	2,14	10,91	51	157,04	311,54	2,54	12,26
26	38	14	93	52	19	83	55	28
41	67	15	95	53	34	312,12	56	30
148,56	294,96	2,16	10,97	54	157,49	312,41	2,57	12,33
71	295,25	16	11,00	55	64	70	57	35
86	54	17	02	56	79	313	58	37
149,00	295,83	2,18	11,04	57	157,94	313,29	2,59	12,40
15	296,12	18	06	58	158,09	58	60	42
30	42	19	08	59	24	87	60	44
149,45	296,71	2,20	11,11	60	158,38	314,16	2,61	12,47

$\theta - 18^\circ$				$R=1000$	$\theta - 19^\circ$			
Doiraviy egri chiziq asosiy elementlari				θ burchagi minutlari	Doiraviy egri chiziq asosiy elementlari			
T	K	D	B		T	K	D	B
158,38	314,16	2,61	12,47	0	167,34	331,61	3,07	13,91
53	45	62	49	1	49	90	08	93
68	74	62	51	2	64	332,19	09	95
158,83	315,03	2,63	12,34	3	167,79	332,49	3,10	13,98
98	32	64	56	4	94	78	11	14,00
159,13	61	65	58	5	168,09	333,07	II	03
159,28	315,90	2,65	12,61	6	168,24	333,36	3,12	14,05
43	316,20	66	63	7	39	65	13	08
58	49	67	65	8	54	94	14	10
159,73	316,78	2,68	12,68	9	168,69	334,23	3,15	14,13
88	317,07	68	70	10	84	52	15	15
160,02	36	69	72	11	99	81	16	18
160,17	317,65	2,70	12,75	12	169,14	335,10	3,17	14,20
32	94	71	77	13	29	39	18	23
47	318,23	71	79	14	44	68	19	25
160,62	318,52	2,72	12,82	15	169,59	335,98	3,20	14,28
77	81	73	84	16	74	336,27	20	30
92	319,10	74	86	17	89	56	21	33
161,07	319,40	2,74	12,89	18	170,04	336,85	3,22	14,36
22	69	75	91	19	18	337,14	23	38
37	98	76	94	20	33	43	24	40
161,52	320,27	2,77	12,96	21	170,48	337,72	3,25	14,43
67	56	77	98	22	63	338,01	26	46
82	85	78	13,01	23	78	30	26	48
161,96	321,14	2,79	13,03	24	170,93	338,59	3,27	14,50
162,11	43	80	06	25	171,08	88	28	53
26	72	80	08	26	23	339,18	29	56
162,41	322,01	2,81	13,10	27	171,38	339,47	3,30	14,58
56	30	82	13	28	63	76	31	60
71	60	83	16	29	68	340,05	32	63
162,86	322,89	2,83	13,17	30	171,83	340,34	3,32	14,66

$\theta - 18^\circ$				R=1000	$\theta - 19^\circ$			
Doyraviy egri chiziq asosiy elementlari					θ burchagi minutlari	Doyraviy egri chiziq asosiy elementlari		
T	K	D	B	T		K	D	B
162,66	322,89	2,83	13,17	30	171,83	340,34	3,32	14,66
163,01	323,18	84	20	31	98	63	33	68
16	47	85	22	32	172,13	92	34	71
163,31	323,76	2,86	13,25	33	172,28	341,21	3,35	14,73
46	324,05	87	27	34	43	50	36	76
61	34	87	30	35	58	79	37	78
163,76	324,63	2,88	13,32	36	172,73	342,08	3,38	14,81
91	92	89	34	37	88	38	38	83
164,05	325,21	90	37	38	173,03	67	39	86
164,20	325,50	2,90	13,39	39	173,18	342,96	3,40	14,88
35	79	91	42	40	33	343,25	41	91
50	326,09	92	44	41	48	54	42	94
164,65	326,38	2,93	13,46	42	173,63	343,83	3,43	14,96
80	67	94	49	43	78	344,12	44	99
95	96	94	51	44	93	41	45	15,01
165,10	327,25	2,95	13,54	46	174,08	344,70	3,45	15,04
25	54	96	56	46	23	99	46	06
40	83	97	59	47	38	345,28	47	09
165,55	328,12	2,98	13,61	48	174,53	345,58	3,48	15,12
70	41	98	64	49	68	87	49	14
85	70	99	66	50	83	346,16	50	17
166,00	328,99	3,00	13,68	51	174,98	346,45	3,51	15,19
15	129,29	01	71	52	175,13	74	52	22
30	58	02	73	53	28	347,03	53	24
166,45	329,87	3,02	13,76	54	175,43	347,32	3,53	15,27
60	330,16	03	78	55	58	61	54	30
74	45	04	81	56	73	90	55	32
166,89	330,74	3,05	13,83	57	175,88	348,19	3,56	15,35
167,04	331,03	06	86	58	176,03	48	57	37
19	32	06	88	59	18	77	58	40
167,34	331,61	3,07	13,91	60	176,33	349,07	3,59	15,43

$\theta - 20^\circ$				R=1000	$\theta - 21^\circ$			
Doyraviy egri chiziq asosiy elementlari				θ burchagi minutlari	Doyraviy egri chiziq asosiy elementlari			
T	K	D	B		T	K	D	B
176,33	349,07	3,59	15,43	0	185,34	366,52	4,16	17,03
48	36	60	45	1	49	81	17	06
63	65	61	48	2	64	367,1	18	09
176,78	349,94	3,62	15,5	3	186,79	367,39	4,19	17,11
93	350,23	62	63	4	94	68	20	14
177,08	52	63	56	5	186,09	97	21	17
177,23	350,81	3,64	15,58	6	18624	368,26	422	17,20
38	351,1	65	61	7	39	56	23	22
63	39	66	64	8	64	85	24	25
177,68	351,68	3,67	15,66	9	186,69	369,14	4,26	17,28
83	97	68	69	10	84	43	26	31
98	352,27	69	71	11	99	72	27	33
178,13	352,56	3,7	16,74	12	187,14	370,01	4,28	17,36
28	85	71	77	13	30	30	29	39
43	363,14	72	79	14	46	59	30	42
178,58	353,43	3,73	15,82	15	187,6	370,88	4,31	17,44
73	72	73	85	16	75	371,17	32	47
88	354,01	74	87	17	90	46	33	50
179,03	354,3	3,75	15,9	18	188,05	371,76	4,34	17,53
18	59	76	93	19	20	372,05	35	56
33	88	77	95	20	35	34	36	58
179,48	355,17	3,76	15,98	21	188,50	372,63	4,37	17,61
63	47	79	16,01	22	65	92	38	64
78	76	60	3	23	80	373,21	39	67
179,93	356,05	3,81	16,06	24	188,95	373,5	4,4	17,69
180,08	34	82	8	28	189,10	79	41	72
23	63	83	11	26	25	374,08	42	75
180,38	356,92	3,84	16,14	27	189,40	374,37	4,43	17,78
63	357,21	85	16	28	55	66	46	81
68	50	S6	19	29	71	95	46	83
180,83	357,79	3,87	16,22	30	189,86	375,25	4,47	17,86

$\theta - 20^\circ$				R=1000	$\theta - 21^\circ$			
Doiraviy egri chiziq asosiy elementlari				θ burchagi minutlari	Doiraviy egri chiziq asosiy elementlari			
T	K	D	B		T	K	D	B
180,83	357,79	3,87	16,22	30	189,86	375,25	4,47	17,86
98	358,08	88	24	31	190,01	54	48	89
181,13	37	89	27	32	16	83	49	92
181,28	358,67	3,89	16,30	33	190,31	376,12	4,50	17,95
43	96	90	33	34	46	41	51	98
58	359,25	91	35	35	61	70	52	18,00
181,73	359,54	3,92	16,38	36	190,76	376,99	4,53	18,03
88	83	93	41	37	91	377,28	54	06
182,03	360,12	94	43	38	191,06	57	55	09
182,18	360,41	3,95	16,46	39	191,21	377,86	4,56	18,12
33	70	96	49	40	36	378,15	57	15
48	99	97	51	41	51	45	58	17
182,63	361,28	3,98	16,54	42	191,66	378,74	4,59	18,2
78	57	99	57	43	82	379,03	60	23
93	86	4,00	59	44	97	32	61	26
183,08	362,16	4,01	16,62	45	192,12	379,61	4,63	18,29
23	45	02	65	46	27	90	64	32
38	74	03	68	47	42	380,19	65	34
183,53	363,03	4,04	16,70	48	192,57	380,48	4,66	18,37
68	32	05	73	49	72	77	67	40
84	61	06	76	50	87	381,06	68	43
183,99	363,90	4,07	16,78	51	193,02	381,35	4,69	18,46
184,14	364,19	08	81	52	17	65	70	49
29	48	09	84	53	32	94	71	52
184,44	364,77	4,10	16,87	54	193,47	382,23	4,72	18,54
59	365,06	11	89	55	63	52	73	57
74	36	12	92	56	78	81	74	60
184,89	365,65	4,13	16,95	57	193,93	383,10	4,76	18,63
185,04	94	14	98	58	194,08	39	77	66
19	366,23	15	17	59	23	68	78	69
185,34	366,52	4,16	17,03	60	194,38	383,97	4,79	18,72

$\theta - 22^\circ$				R=1000	$\theta - 23^\circ$			
Doyraviy egri chiziq asosiy elementlari				θ burchagi minutlari	Doyraviy egri chiziq asosiy elementlari			
T	K	D	B		T	K	D	B
194,38	383,97	4,79	18,72	0	203,45	401,43	5,48	20,49
53	384,26	80	76	1	60	72	49	52
68	55	81	77	2	76	402,01	50	55
194,83	384,85	4,82	18,80	3	203,91	402,30	5,52	20,58
98	385,14	83	83	4	204,06	59	53	61
195,14	43	84	86	5	21	88	54	64
195,29	385,72	4,85	18,89	6	204,36	403,17	5,55	20,67
44	386,01	87	92	7	51	46	56	70
59	30	88	95	8	66	75	58	73
195,74	386,59	4,89	18,98	9	204,82	404,04	5,59	20,76
89	88	90	19,01	10	97	33	60	79
196,04	387,17	91	03	11	205,12	63	61	82
196,19	387,46	4,92	19,06	12	205,27	404,92	5,62	20,85
34	75	93	09	13	42	405,21	64	88
49	388,04	94	12	14	57	50	65	91
196,65	388,34	4,96	19,15	15	205,73	405,79	5,66	20,94
80	63	97	18	16	88	406,08	67	97
95	92	98	21	17	206,03	37	69	21
197,10	389,21	4,99	19,24	18	206,18	406,66	5,70	21,03
25	50	5,00	27	19	33	95	71	06
40	79	01	30	20	48	407,24	72	10
197,55	390,08	5,02	19,33	21	206,64	407,33	5,74	21,13
70	37	03	36	22	79	83	75	16
85	66	05	39	23	94	408,12	76	19
198,01	390,95	5,06	19,41	24	207,09	408,41	5,77	21,22
16	391,24	07	44	25	24	70	79	25
31	54	08	47	26	39	99	80	28
198,46	391,83	5,09	19,5	27	207,55	409,28	5,61	21,31
61	392,12	10	53	28	70	57	82	34
76	41	11	56	29	85	86	84	37
198,91	392,7	5,13	19,59	30	208,00	410,15	5,85	21,40

$\theta - 22^\circ$

R=1000

 $\theta - 23^\circ$

Doyraviy egri chiziq asosiy elementlari				θ burchagi minutlari	Doyraviy egri chiziq asosiy elementlari			
T	K	D	B		T	K	D	B
198,91	392,70	5,13	19,59	30	208,00	410,15	5,85	21,40
109,06	99	14	62	31	15	44	80	43
21	393,28	15	65	32	30	73	87	46
199,37	393,57	5,16	19,68	33	208,46	411,03	5,89	21,50
52I	86	17	71	34	61	32	90	53
67	394,15	18	74	35	76	61	91	56
199,82	394,44	5,20	19,77	36	208,91	411,90	5,92	21,59
97	74	21	80	37	209,06	412,19	94	62
200,12	395,03	22	83	38	21	48	95	66
200,27	395,32	5,23	19,86	39	209,37	412,77	5,96	21,68
42	61	24	89	40	52	413,06	98	71
68	90	25	92	41	67	35	99	74
200,73	396,19	5,27	19,95	42	209,82	413,64	6,00	21,78
86	48	28	98	43	97	93	01	81
201,03	77	29	20,01	44	210,13	414,22	03	84
201,18	397,06	5,30	20,04	46	210,28	414,52	6,04	21,87
33	35	31	07	46	43	81	05	90
48	64	32	10	47	58	415,10	07	93
201,64	397,94	5,34	20,13	48	210,73	415,39	6,08	21,96
79	398,23	35	16	49	88	68	09	99
94	52	36	19	50	211,04	97	10	22,03
202,09	398,81	5,37	20,22	51	211,19	416,26	6,12	22,06
24	399,10	38	25	52	34	55	13	09
39	39	40	28	53	49	84	14	12
202,54	399,68	5,41	20,31	54	211,64	417,13	6,16	22,15
70	97	42	34	55	80	42	17	18
85	400,26	43	37	56	95	72	18	21
203,00	400,55	5,44	20,40	57	212,10	418,01	6,19	22,25
15	84	45	43	58	25	30	21	28
30	401,13	47	46	59	40	59	22	31
203,45	401,43	5,48	20,49	60	212,56	418,88	6,23	22,34

$\theta - 24^\circ$

R=1000

 $\theta \alpha - 25^\circ$

Doiraviy egri chiziq asosiy elementlari				θ burchagi minutlari	Doiraviy egri chiziq asosiy elementlari			
T	K	D	B		T	K	D	B
212,56	418,88	6,23	22,34	0	221,69	436,33	7,05	24,28
71	419,17	25	37	1	85	62	07	31
86	46	26	40	2	222,00	91	09	35
213,01	419,75	6,27	22,44	3	222,15	437,20	7,10	24,38
16	420,04	29	47	4	31	50	11	41
32	33	30	50	5	46	79	13	44
213,47	420,62	6,31	22,53	6	222,61	438,08	7,14	24,48
62	92	33	56	7	76	37	15	51
77	421,21	34	59	8	92	66	17	54
213,93	421,50	6,35	22,63	9	223,07	438,95	7,19	24,58
214,08	79	37	66	10	22	439,24	20	61
23	422,08	38	69	11	37	53	22	64
214,38	422,37	6,39	22,72	12	223,53	439,82	7,23	24,68
53	66	41	75	13	68	440,11	24	71
69	95	42	79	14	83	40	26	74
214,84	423,24	6,43	22,82	15	223,98	440,70	7,27	24,78
99	53	45	85	16	224,14	99	29	81
216,14	82	46	88	17	29	441,28	30	84
215,29	424,11	6,47	22,91	18	224,44	441,57	7,32	24,88
45	41	49	95	19	60	86	33	91
60	70	50	98	20	76	442,15	35	94
215,75	424,99	6,51	23,01	21	224,90	442,44	7,36	24,98
90	425,28	53	04	22	225,05	73	38	25,01
216,06	57	54	07	23	21	443,02	39	05
216,21	425,86	6,56	23,11	24	225,36	443,31	7,41	25,08
36	426,15	57	14	25	51	60	42	11
51	44	58	17	26	67	90	44	16
216,66	426,73	6,60	23,20	27	225,82	444,19	7,45	25,18
82	427,02	61	23	28	97	48	47	21
97	31	62	27	29	226,12	47	48	25
217,12	427,61	6,64	23,30	30	226,28	445,06	7,49	25,28

$\theta - 24^\circ$				R=1000	$\theta - 25^\circ$			
Doyraviy egri chiziq asosiy elementlari				θ burchagi minutlari	Doyraviy egri chiziq asosiy elementlari			
T	K	D	B		T	K	D	B
217,12	427,61	6,64	23,30	30	226,28	445,06	7,49	25,28
27	90	65	33	31	43	35	51	31
43	428,19	66	36	32	58	64	52	35
217,58	428,48	6,68	23,40	33	226,74	445,93	7,54	25,38
73	77	69	43	34	89	446,22	55	42
88	429,06	71	46	35	227,04	51	57	45
218,04	429,35	6,72	23,49	36	227,19	446,80	7,58	25,48
19	64	73	53	37	35	447,10	60	52
34	93	75	56	38	50	39	61	55
218,49	430,22	6,76	23,59	39	227,65	447,68	7,63	25,59
64	51	78	62	40	81	97	64	62
80	81	79	66	41	69	448,26	66	65
218,95	431,10	6,80	23,69	42	228,11	448,55	7,68	25,69
219,10	39	82	72	43	27	84	69	72
25	68	83	75	44	42	449,13	71	76
219,41	431,97	6,84	23,79	46	228,57	449,42	7,72	25,79
56	432,26	86	82	46	72	71	74	82
71	55	87	85	47	88	450,00	75	86
219,86	432,84	6,89	23,88	48	229,03	450,29	7,77	25,89
220,02	433,13	90	92	49	18	59	78	93
17	42	92	95	50	34	88	80	96
220,32	433,71	6,93	23,98	51	229,49	451,17	7,81	25,99
47	434,01	94	24,02	52	64	46	83	26,03
63	30	96	05	53	80	75	84	06
220,78	434,59	6,97	24,08	54	229,95	452,04	7,86	26,10
93	88	99	11	55	230,10	33	87	13
221,08	435,17	7,00	15	56	26	62	90	17
221,24	435,46	7,01	24,18	57	230,41	452,91	7,91	26,20
39	75	03	21	58	56	453,20	92	24
54	436,04	04	25	59	71	49	93	27
221,69	436,33	7,05	24,28	60	230,87	453,79	7,95	26,30

$\theta - 26^\circ$				R=1000	$\theta - 27^\circ$			
Doyraviy egri chiziq asosiy elementlari				θ burchagi minutlari	Doyraviy egri chiziq asosiy elementlari			
T	K	D	B		T	K	D	B
230,87	463,79	7,95	26,30	0	240,08	471,24	8,92	28,42
231,02	454,08	96	34	1	23	53	94	45
17	37	98	37	2	39	82	95	49
231,33	454,66	8,00	26,41	3	240,54	472,11	8,97	28,52
48	96	01	44	4	69	40	99	66
63	455,24	03	48	5	85	69	9,00	60
231,79	465,63	8,04	26,51	6	241,00	472,98	9,02	28,63
94	82	06	56	7	16	473,28	04	67
232,09	466,11	08	58	8	31	57	05	70
232,25	456,40	8,09	26,62	9	241,46	473,86	9,07	28,74
40	69	11	65	10	62	474,15	09	78
65	99	12	68	11	77	44	10	81
232,71	467,28	8,14	26,72	12	241,93	474,73	9,12	28,85
86	57	15	75	18	242,08	476,02	14	88
233,01	86	17	79	14	23	31	16	92
233,17	458,15	8,19	26,82	15	242,39	476,60	9,17	28,96
32	44	20	86	16	54	89	19	99
47	73	22	89	17	70	476,18	21	29,03
233,63	459,02	8,23	26,93	18	242,85	476,47	9,22	29,07
78	31	25	96	19	243,00	77	24	10
93	60	27	27,00	20	16	477,06	26	14
234,09	459,89	8,28	27,03	21	24331	477,35	9,28	29,17
24	460,19	30	07	22	47	64	29	21
39	48	31	10	23	62	93	81	25
234,55	460,77	8,33	27,14	24	243,77	478,22	9,33	29,28
70	461,06	34	17	25	93	51	34	32
85	35	36	21	26	244,08	80	36	36
235,01	461,64	8,38	27,24	27	244,24	479,09	9,38	29,39
16	93	39	28	28	39	38	40	43
32	462,22	41	31	29	54	67	41	47
238,47	462,51	8,43	27,35	30	244,70	479,97	9,43	29,50

$\theta - 26^\circ$

R=1000

 $\theta - 27^\circ$

Doyraviy egri chiziq asosiy elementlari				θ burchagi minutlari	Doyraviy egri chiziq asosiy elementlari			
T	K	D	B		T	K	D	B
235,47	462,51	8,43	27,35	30	244,70	479,97	9,43	29,50
62	80	44	38	31	85	480,26	45	54
78	463,09	46	42	32	245,01	55	47	58
235,93	463,38	8,47	27,45	33	245,16	480,84	9,48	29,61
236,08	68	49	49	34	32	481,13	50	65
24	97	51	53	35	47	42	52	69
236,39	464,26	8,52	27,56	38	245,62	481,71	9,54	29,72
64	55	54	60	37	78	463,00	56	76
70	84	55	63	38	93	29	57	80
236,85	465,13	8,57	27,67	39	246,09	482,58	9,59	29,83
237,00	42	59	70	40	24	87	61	87
16	71	60	74	41	39	483,17	62	91
237,31	466	8,62	27,77	42	246,55	483,46	9,64	29,94
47	29	64	81	43	70	75	66	98
62	68	65	84	44	86	484,04	68	30,02
237,77	466,88	8,67	27,88	45	247,01	484,33	9,70	30,06
93	467,17	69	91	46	17	62	71	09
238,08	46	70	95	47	32	91	73	13
238,23	467,75	8,72	27,99	48	247,47	485,20	9,76	30,17
39	468,04	74	28,02	49	63	49	77	20
54	33	75	06	50	78	78	78	24
238,69	468,62	8,77	28,09	51	247,94	486,07	9,80	30,28
85	91	79	13	62	248,09	37	82	32
239,00	469,20	80	16	53	26	66	84	35
239,16	469,49	8,82	28,20	54	248,40	486,95	9,86	30,39
31	78	84	24	55	56	487,24	87	43
46	470,08	85	27	56	71	53	89	46
239,62	470,37	8,87	28,31	57	248,86	487,82	9,91	30,5
77	66	89	34	58	249,02	488,11	93	54
92	95	90	38	59	17	40	95	58
240,08	471,24	8,92	28,42	60	249,33	488,69	9,97	30,61

$\theta - 28^\circ$				R=1000	$\theta - 29^\circ$			
Doyraviy egri chiziq asosiy elementlari				θ burchagi minutlari	Doyraviy egri chiziq asosiy elementlari			
T	K	D	B		T	K	D	B
249,33	488,69	9,97	30,61	0	258,62	506,15	11,09	32,90
48	98	98	66	1	77	44	11	94
64	489,27	10,00	69	2	93	73	13	98
249,79	489,56	10,02	30,73	3	259,08	507,02	11,15	33,02
95	86	04	76	4	24	31	17	06
250,10	490,15	05	80	5	39	60	19	09
250,26	490,44	10,07	30,84	6	259,55	507,89	11,21	33,13
41	73	09	88	7	70	508,18	23	17
56	491,02	11	91	8	86	47	25	21
250,72	491,31	10,13	30,95	9	260,01	508,76	11,27	33,25
87	60	15	99	10	17	509,05	29	29
251,03	89	16	31,03	11	33	35	31	33
251,18	192,18	10,18	31,66	12	260,48	509,64	11,32	33,87
34	47	20	10	13	64	93	34	41
49	76	22	14	14	79	510,22	36	45
251,65	493,06	10,24	31,18	15	260,95	510,51	11,38	33,49
80	35	26	21	16	261,10	80	40	53
96	64	27	25	17	26	511,09	42	56
252,11	493,93	10,29	31,29	18	261,41	511,38	11,44	33,60
27	494,22	31	33	19	57	67	46	64
42	51	33	37	20	72	96	48	68
252,57	494,80	10,35	31,40	21	261,88	512,25	11,50	33,72
73	495,09	37	44	22	262,03	55	52	76
88	38	39	48	23	19	84	54	80
253,04	495,67	10,40	31,52	24	262,35	513,13	11,56	33,84
19	96	42	56	25	60	42	58	88
35	496,26	44	59	26	66	71	60	92
253,5	496,55	10,46	31,63	27	262,81	514,00	11,62	33,96
66	84	48	67	28	97	29	64	34,00
81	497,13	50	71	29	263,12	58	66	04
253,97	497,42	10,52	31,76	30	263,28	514,87	11,68	34,08

$\theta - 28^\circ$				R=1000	$\theta - 29^\circ$			
Doyraviy egri chiziq asosiy elementlari				θ burchagi minutlari	Doyraviy egri chiziq asosiy elementlari			
T	K	D	B		T	K	D	B
253,97	497,42	10,52	31,75	30	263,28	514,87	11,68	34,08
254,12	71	54	78	31	43	515,16	70	12
28	498,00	55	82	32	59	45	72	16
254,43	498,29	10,57	31,86	33	263,74	515,74	11,74	4,20
59	58	59	90	34	90	516,04	76	24
74	87	61	94	35	264,06	33	79	28
254,9	499,16	10,63	31,97	36	264,21	516,62	11,81	34,32
255,05	46	65	32,01	37	37	91	83	35
21	75	67	05	38	52	517,20	85	39
255,3	500,01	10,69	32,09	39	264,68	517,49	11,87	34,43
52	33	71	13	40	83	78	89	47
67	62	72	17	41	99	518,07	91	51
255,83	500,91	10,74	32,20	42	265,15	518,36	11,93	34,55
98	501,20	76	24	43	30	66	95	59
256,14	49	78	28	44	46	94	97	63
256,29	501,78	10,80	32,32	46	265,61	519,24	11,99	34,67
45	502,07	82	36	46	77	53	12,01	71
60	36	84	40	47	92	82	03	75
256,76	502,65	10,86	32,44	48	266,08	520,11	12,05	34,79
91	95	88	47	49	24	40	07	83
257,07	503,24	90	51	50	39	69	09	87
257,22	503,53	10,92	32,55	51	266,55	520,98	12,11	34,91
38	82	93	59	52	70	521,27	13	95
53	504,11	95	63	53	86	56	15	99
257,69	504,4	10,97	32,67	54	267,01	521,85	12,17	35,03
84	69	99	71	55	17	522,14	20	07
258	98	11,01	75	56	33	14	22	11
258,15	505,27	11,03	32,78	57	267,48	522,73	12,24	35,16
31	66	05	82	58	64	523,03	26	20
46	85	07	86	59	79	31	28	24
258,62	506,16	11,09	32,90	60	267,95	523,60	12,30	35,28

II.1. Egri chiziq bosh nuqtalari piket o'rnini hisoblash

Temir yo'l o'q chizig'ini trssalash (piketlash) jarayonida har bir burilish uchining piket o'rnini aniqlab boriladi va piketlash daftarchasiga yoziladi, masalan, $BU_{pk} = 6 + 72.50m$.

BU_{pk} o'rnini va egri chiziq elementlari orqali egri chiziq bosh nuqtalari EB, EO' va EO ning (1-rasm) piket o'rnini hisoblanadi.

Masalan:

$$\begin{array}{r}
 BU Pk 6 + 72,50 \\
 \underline{-T \quad 1 \quad 01,84} \\
 EB Pk 5 + 70,66 \\
 \underline{+ K \quad 1 \quad 99,43} \\
 EO Pk 7 + 70,09
 \end{array}
 \qquad
 \begin{array}{r}
 EB Pk 5 + 70,66 \\
 \underline{+ K/2 \quad 99,72} \\
 EO' Pk 6 + 70,38
 \end{array}$$

Tekshirish

$$\begin{array}{r}
 EB Pk 5 + 70,66 \\
 \underline{+ 2T \quad 2 \quad 03,68} \\
 7 + 74,34 \\
 \underline{-D \quad 14,24} \\
 EO Pk 7 + 70,10
 \end{array}
 \qquad
 \begin{array}{r}
 BU Pk 6 + 72,50 \\
 \underline{-0,5D \quad 2,12} \\
 EO' Pk 6 + 70,38
 \end{array}$$

III. Egri chiziq bosh nuqtalarini joyda rejalash

Buning uchun egri chiziq burilish uchiga teodolit o'rnatiladi va ish holatiga keltiriladi. Ko'rish trubasi trassaning burilishidan oldingi yo'nalish tomonga (oldingi burilish uchiga yoki burilishgacha joylashgan oxirgi piketga) qaratilib, limb va alidada qotiriladi. So'ng ko'rish trubasi tik tekislik bo'yicha gorizontalar o'qi atrofida aylantiriladi hamda qarama-qarshi tomonga qaratiladi va gorizontalar doyradan sanoq olinadi. Bu sanoqqa burilish burchagi θ qo'shiladi, agar trassa o'ng tomonga burilsa, yoki ayiriladi, agar chap tomonga burilsa, va yangi yo'nalish sanog'i topiladi. Keyin ko'rish trubasi gorizontalar doirada shu hisoblangan sanoq o'rnashgunga qadar tegishli o'ng yoki chap tarafga buriladi.

Endi, dastlab, hosil bo'lgan trassaning yangi yo'nalishi bo'ylab, keyin esa burilishidan oldingi yo'nalishi bo'ylab masofa o'lchash asboblari yordamida tangens uzunligi (T) o'lchab qo'yilib, egri chiziq oxiri (EO) va egri chiziq boshi (EB) qoziq bilan belgilanadi.

Egri chiziq o'rtasining o'rnini belgilash uchun, trassaning burilishidan keyingi yo'nalishiga to'g'ri kelgan gorizontalar doira sanog'iga ichki burchak β ning yarmisi ($\beta/2$) qo'shiladi (agar burilish o'ngga bo'lsa), burilish chap tarafga bo'lganda $360^\circ - \beta = \gamma$ burchak hisoblanadi va keyingi

yo'nalish sanog'idan $\gamma/2$ ayriladi (2-rasm). Hosil bo'lgan son ichki burchak bissektrisa yo'nalishiga mos gorizontal doira sanog'idir. Ko'rish trubasi gorizontal doirada shu sanoq o'rnamshunga qadar buriladi va ko'rish nuri yo'nalishi bo'yicha lenta tortilib, bissektrisa uzunligi (B) o'lchab qoziq qoqiladi.

IV. Doiraviy egri chiziqlarni batafsil rejalash

Joyda egri chiziq bosh nuqtalari belgilangandan keyin, uni batafsil rejalashga o'tiladi. Egri chiziq nuqtalarini joyda bir-biridan teng masofada (5,10 yoki 20m) belgilash **batafsil rejalash** deyiladi.

Joy sharoitlari, burilish burchagining katta-kichikligiga va mavjud ish asboblariga qarab batafsil rejalash usullari tanlanadi.

IV.1. To'g'ri burchakli koordinatalar usuli

Bu usulda EB va EO nuqtalari koordinatalar boshi, tangens chizig'i $-x$ o'qi va unga perpendikulyar yo'nalish bo'yicha $-y$ o'qi deb qabul qilinadi.

Rejalashni amalga oshirish uchun to'g'ri burchakli koordinatalar x va y ma'lum bo'lishi kerak. Ular quyidagi formulalar bo'yicha hisoblanadi.

$$x = R \sin \varphi;$$

$$y = 2R \sin \frac{\varphi}{2},$$

bunda R – egri chiziq radiusi;

φ – yoy uzunligi “K”ga mos markaziy burchak.

$$\varphi = \frac{180^\circ}{\pi R} K = \frac{\rho}{R} K,$$

bunda K – EB dan tangens bo'yicha rejalanayotgan nuqtagacha masofa.

Bu usulda egri chiziqni joyda rejalash quyidagicha amalga oshiriladi: masofa o'lchash asbobi yordamida egri chiziq boshidan (EB) tangens (T) yo'nalishi bo'ylab K (10,20,30,... m) kesimlar o'lchab qo'yiladi. Har 10m ga mos x masofa belgilanib undan tangensga perpendikulyar ravishda y ordinatalar o'lchab qo'yiladi.

Masalan, R = 300m uchun, birinchi 10m da $x = 9.99m$ belilanadi, hamda tangens yo'nalishiga perpendikulyar ravishda $y = 0.17m$ o'lchab qo'yilib, egri chiziqning 1-nuqtasiga qoziq qoqiladi. So'ng EB dan ikkinchi 10 metrida $x = 19.99m$ belgilanadi, undan $y = 0.67m$

perpendikulyar chiqarilib egri chiziqning 2-nuqtasiga qoziq qoqiladi va h.k. (3-rasm).

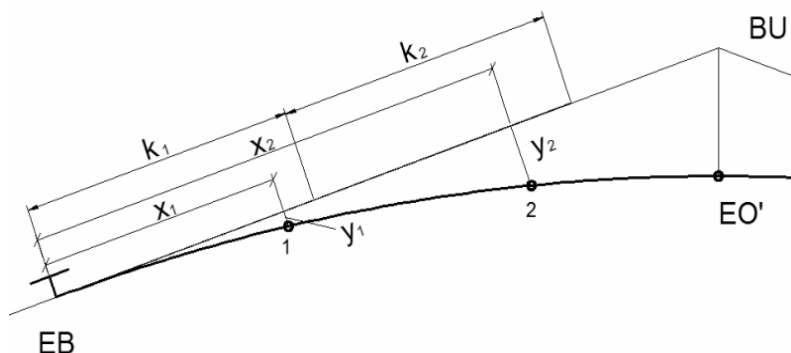

3-rasm

2 – jadvalda x va y koordinatalar “K” ning 10m dan 200m gacha qiymatlari hamda turli radiuslar uchun berilgan.

2-jadval

K, m	R=200m		R=300m		R=400m		R=500m	
	x, m	y, m	x, m	y, m	x, m	y, m	x, m	y, m
10	10	0.25	9.99	0.17	10.00	0.13	10.00	0.10
20	19.97	1.00	19.99	0.67	19.99	0.50	19.99	0.40
30	29.89	2.25	29.95	1.50	29.97	1.12	29.98	0.90
40	39.73	3.99	39.88	2.66	39.93	2.00	39.96	1.60
50	49.48	6.22	49.77	4.16	49.87	3.12	49.92	2.50
60	59.10	8.93	59.60	5.98	59.78	4.49	59.86	3.60
70	68.58	12.12	69.37	8.13	69.64	6.11	69.77	4.89
80	79.89	15.79	79.06	10.60	79.47	7.47	79.66	6.39
90	89.99	19.91	88.66	13.40	89.24	10.08	89.51	8.08
100	98.24	23.46	98.16	16.51	98.96	12.44	99.33	9.97

Shu tarzda nuqtalar egri chiziq o’rtasigacha (EO’) belgilab chiqiladi. Egri chiziqning ikkinchi yarmi xuddi shunday tartibda uning oxiri (EO) dan boshlab egri chiziq o’rtasigacha rejalab kelinadi.

IV.2. Burchaklar usuli

Bunda dastlab rejalash burchagi φ hisoblanadi:

$$\sin \varphi = \frac{K}{2R},$$

bu yerda K – vatar uzunligi (egri chiziqning ketma-ket joylashgan nuqtalar orasidagi masofa). $K=10m$ yoki $20m$ deb tanlab olinadi;

R – egri chiziq radiusi;

φ – bu tangens chizig’i bilan egri chiziqning rejalanayotgan nuqtaga yo’nalish orasidagi burchak (4-rasm).

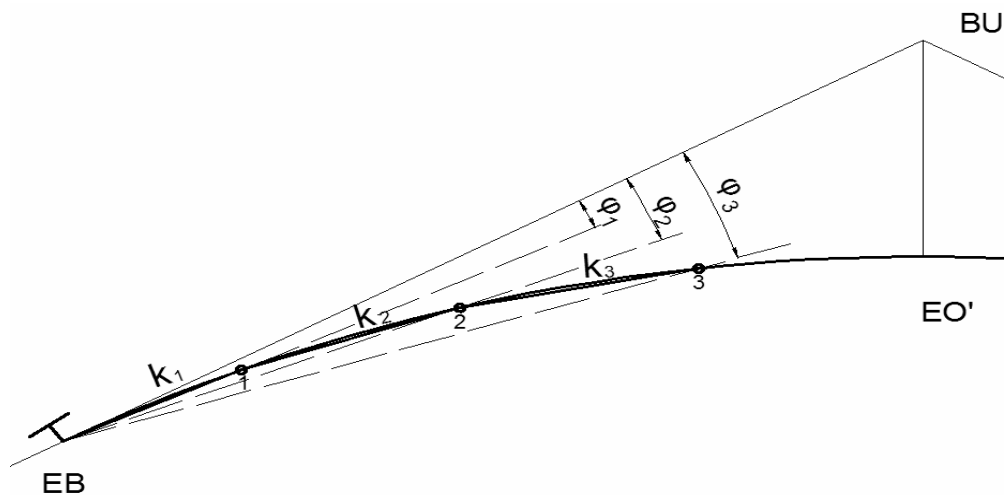

4-rasm

Bu usulda egri chiziqni rejalash quyidagicha olib boriladi.

Egri chiziq bosh (EB) nuqtasiga teodolit gorizontaal doira sanog'i $0^{\circ}00'$ ga keltirilib, ko'rish trubasi burilish uchi (BU) dagi vexaga qaratiladi (4-rasm). Limb qotirilib, alidada bo'shatiladi va gorizontaal doiradagi sanoq φ ga teng bo'lgunga qadar ko'rish trubasi buraladi. Shunda, agar burilish o'ng tomonga bo'lsa, gorizontaal doirada φ , 2φ , 3φ burchaklarga teng sanoqlar ketma-ket truba o'ng tomonga aylantirilgan holda o'rnatiladi; agarda burilish chapga bo'lsa, ko'rish trubasi $360^{\circ} - \varphi$, $360^{\circ} - 2\varphi$, $360^{\circ} - 3\varphi$ va h.k. ga teng sanoqlargacha chap tomonga aylantiriladi. So'ng ko'rish nuri yo'nalishi bo'yicha lenta tortilib, vatar uzunligi $K=20\text{m}$ o'lchab qo'yiladi va chiziqning birinchi nuqtasi (1) belgilanadi. Shundan keyin ko'rish trubasini 2φ burchagiga teng sanoqqacha aylantiriladi, lentaning boshi egri chiziqning 1chi nuqtasida ushlab turiladi, keyingi uchi esa trubaning ko'rish nuri bilan kesishguncha tarang tortiladi va shu yerda egri chiziqning ikkinchi nuqtasi (2) belgilanadi.

3-jadval

Burchaklar usulida rejalash elementlari

R, m		200	300	400	500
		° ' "	° ' "	° ' "	° ' "
20	φ_1	2 51 58	1 54 37	1 25 57	1 08 46
	φ_2	5 43 55	3 49 14	2 51 54	2 17 31
	φ_3	8 35 53	5 43 50	4 17 51	3 26 17
	φ_4	11 27 50	7 38 27	5 43 48	4 35 02
	φ_5	14 19 48	9 33 04	6 52 33	5 43 48
	φ_6	17 11 45	11 27 41	8 01 19	6 52 33
	φ_7	20 03 43	13 22 17	10 01 40	8 01 19

Xuddi shu tartibda 3,4,5 va h.k. nuqtalar o'zni topiladi. 3 – jadvalda vatar $K=20m$ ga mos turli radiuslar uchun rejalash burchaklari $\varphi_1, \varphi_2, \varphi_3, \dots$ miqdorlari keltirilgan.

Egri chiziqni bu usulda ham rejalash alohida EB dan EO' gacha va EO dan EO' gacha amalga oshiriladi.

IV.3. Vatarlarni davom etish usuli

Bu usulda egri chiziq boshi (EB) dan tangens yo'nalishida birinchi $K=10m$ kesma o'lchab qo'yiladi, uning oxiri A_1 dan tangens (T) ga perpendikulyar yo'nalish bo'yicha d_1 masofa o'lchanadi va birinchi nuqta belgilanadi (5-rasm). Lentaning boshi egri chiziq boshi (EB) da ushlab turiladi, 10 chi metri esa 1 chi nuqtaga ko'chiriladi. So'ng EB-1 chiziq davomiga yana $K=10m$ o'lchanib, A_2 nuqtadan perpendikulyar yo'nalish bo'yicha $2d$ kesma qo'yiladi va 2 chi nuqta belgilanadi, hamda lentaning oxiri unga ko'chiriladi.

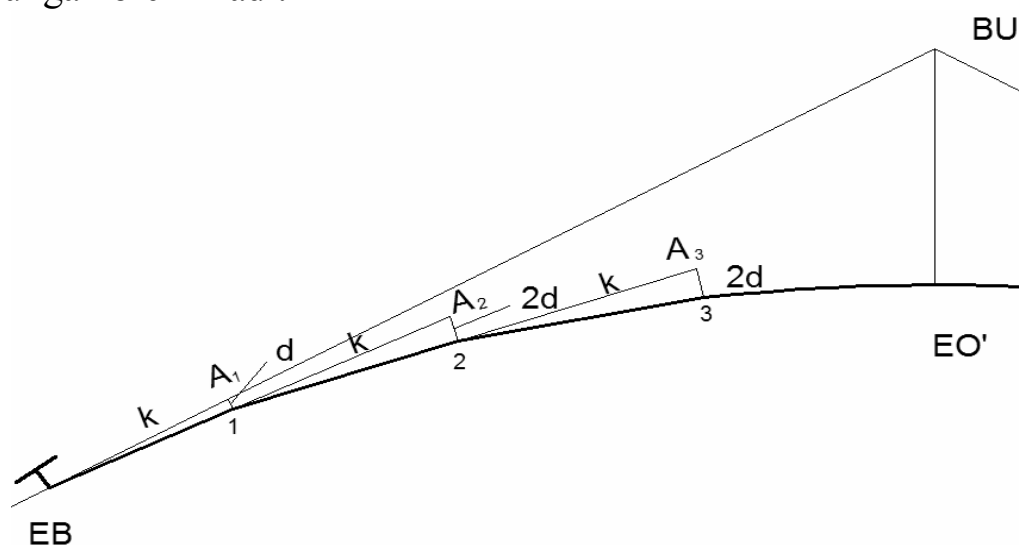

5-rasm

Yana 1-2 chiziq davomida 2- A_3 yo'nalish bo'ylab $K=10m$ masofa o'lchanib, keyin A_3 nuqtadan perpendikulyar bo'yicha $2d$ kesma o'lchanib qo'yiladi va 3 nuqta belgilanadi.

Egri chiziq xordasi $K=10m$ va perpendikulyar siljishi d elementlari orqali batafsil rejalaniadi.

$$d = \frac{K^2}{2R}$$

d larning qiymati egri chiziq radiusiga ko'ra 4-jadvalda keltirilgan.

Egri chiziq radiusi, m	Vatar K, m	Perpendikulyar siljishlar, m	
		d	2d
200	10	0.25	0.50
	20	1.00	2.00
300	10	0.17	0.33
	20	0.67	1.33
400	10	0.12	0.25
	20	0.50	1.00
500	10	0.10	0.20
	20	0.40	0.80

IV. Karrali egri chiziqlar va ularni rejalash

Temir yo'lni qidiruvi va loyihalash jarayonida, agar joy tor (tog'li hudud, shahar sharoiti va h.k.) hamda burilish burchagi katta bo'lsa, egri chiziqni batafsil rejalash uchun uni bir nechta teng bo'lakka bo'linadi va har bir qismining uzunligi 100m, 10m yoki 5m ga qoldiqsiz bo'linishi kerak.

Bunday egri chiziqlarni uzunligi karrali deb nomlanadi, ularning burilish burchagi qiymati kichik olinadi, uzunligi esa shu burilish burchagi Q va radiusi R orqali hisoblab topiladi. AYEC ni batafsil rejalash uchun (6-rasm) uni, masalan, 2 teng qismga AB_1E va CB_2E ga bo'lib olinadi va har biri alohida-alohida rejalalanadi. Bunda $AB_1=B_1E=EB_2=B_2C=T$ lar egri chiziqlarning tangenslari bo'lib, uzunligi

$$T = R \cdot \operatorname{tg}\left(\frac{Q}{4}\right)$$

formula bo'yicha hisoblanadi.

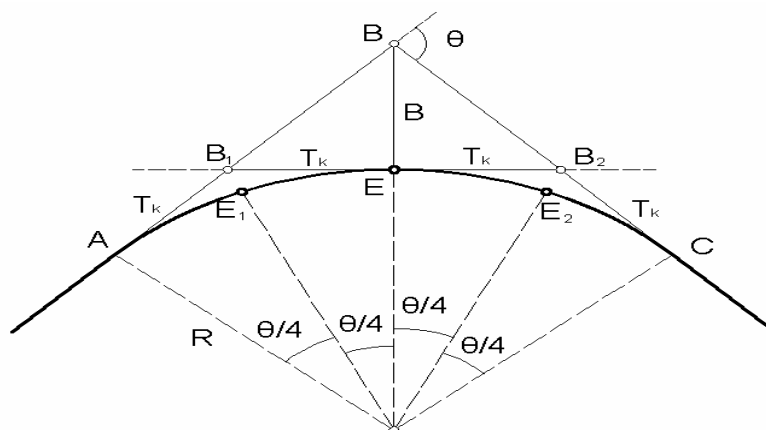

6-rasm

A va C nuqtalardan B nuqta tomon $AB_1 = CB_2$ kesmalar o'lchanib qo'shiladi va B_1 bilan B_2 nuqtalar AE_1E va CE_2E karrali egri chiziqlarning burilish uchi bo'ladi.

Bu egri chiziqlar odatda to'g'ri burchakli koordinatalar usulida batafsil rejalaniadi.

V. O'tish egri chiziqlari

O'tish egri chiziqlari doiraviy egri chiziqning ikki tarafida (boshi va oxirida) joylashib, temir yo'lni to'g'ri qismidan egri qismiga o'tishni osonlashtirish maqsadida barpo etiladi (7-rasm).

Temir yo'llarda o'tish egri chiziqlari radiodal spiral yoki klotoida shaklida bo'ladi. 7-rasmda ℓ - o'tish egri chiziq uzunligi, K - doiraviy egri chiziq qoldiq qismi uzunligi; ρ - doiraviy egri chiziq surilishi;

$$Q' = Q - 24 - \text{doiraviy egri chiziq burilish burchagi } \varphi = \frac{\rho \cdot \ell}{2R} \text{ (}\rho\text{-radian).}$$

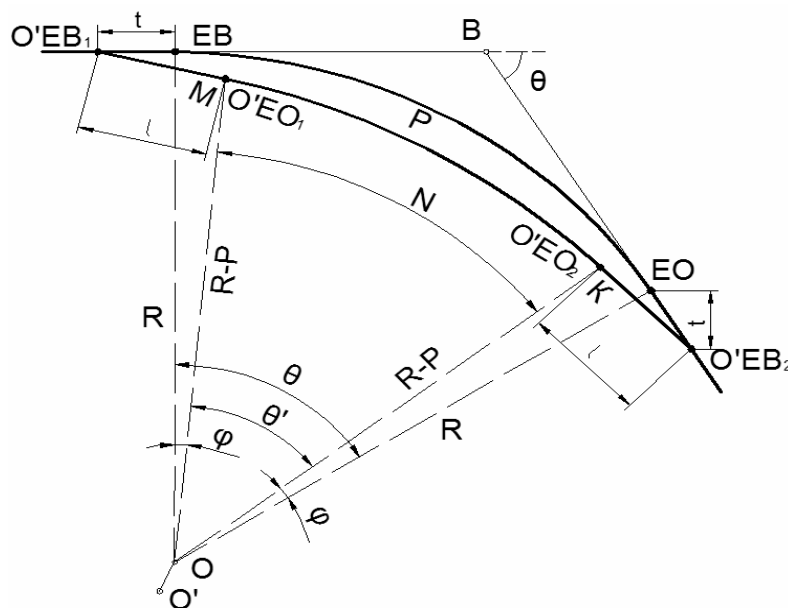

7-rasm. O'tish egri chizig'i elementlari

O'tish egri chiziqni qo'shish burilish burchagini kamayishiga olib keladi. Shuni bilish kerakki, o'tish egri chiziqlarni faqat $\theta \geq 2\varphi$ yoki $K \geq \ell$ bo'lganda, qurish mumkin. Temir yo'l qurilishida, odatda, $K \geq \ell + 10i$ ga teng qilib olinadi.

Doiraviy egri chiziq surilishi quyidagi formula bo'yicha hisoblanadi:

$$p \approx \ell^2 / (24.R).$$

Birinchi o'tish egri chizig'i boshi ($O'EB$) ning hamda ($O'EO_2$) ning o'rinlarini joyda belgilash uchun, doiraviy egri chiziq tangenslari VEB va VEO ni qo'shimcha t masofaga surish kerak:

$$t \approx \frac{\ell}{2}.$$

Surilish miqdori "t" katta radiuslarda kichik bo'ladi, shuning uchun rejalash jarayonida ko'pincha u e'tiborga olinmaydi.

Ammo $R \leq 1000i$ radiusni R miqdoriga kamaytirmaslik maqsadida, doiraviy egri chiziq markazi O ichkari tomonga O' nuqtaga bissektrisa yo'nalishi bo'yicha suriladi:

$$OO' = P \sec \frac{\theta}{2}.$$

Bunda umumiy tangens

$$T = T_k + T_p + t; \quad B = B_k + p \sec \frac{\alpha}{2},$$

bu yerda T_k, A_e - doiraviy egri chiziq tangensi;

$$T_p = P \cdot \operatorname{tg} \frac{\theta}{2}.$$

VI. Piketlarni tangens chizig'idan egri chiziqqa ko'chirish

Ko'p hollarda egri chiziq tangensida piketlar joylashgan bo'lishi mumkin va ularni tangensdan egri chiziqqa ko'chirish zarur (8-rasm).

Piketni ko'chirish koordinatalar usuli bilan bajariladi, buning uchun piket nuqtaning koordinatalari hisoblanishi kerak. Bunda avval egri chiziq boshidan shu piketgacha bo'lgan masofa X hisoblanadi. X ni uzunligi piketning trassa boshidan egri chiziq boshi (EB) ni piket o'rining ayirmasiga teng bo'ladi:

$$K_{nk} = \Pi K - \mathcal{E} B_{nk}.$$

Bu son EB dan egri chiziq bo'ylab GK gacha bo'lgan masofasi.

Bu yoy qiymati bo'yicha bunga to'g'ri kelgan markaziy burchakni ϑ desak, quyidagi formula bo'yicha hisoblanadi:

$$\vartheta = \frac{\Pi R \cdot K_{nk}}{180^\circ} = \frac{180^\circ}{3,14 \cdot 300} \cdot 39,44 = 7^\circ 32'.$$

Keyin to'g'ri burchakli koordinatalarni hisoblash formulalari bo'yicha

$$X_{nk} = R \cdot \sin \varphi_{nk}$$

$$Y_{nk} = 2R \sin^2 \frac{\varphi_{nk}}{2} \text{ ga teng.}$$

Piket o'rnini egri chiziqqa ko'chirishda qulaylik yaratish uchun har metrda K_{Pk} qiymati berilgan maxsus jadval tuzilgan (5- jadval).

5- jadval

k	Koordinatar		k	Koordinatar		k	Koordinatar		k	Koordinatar	
	x	y		x	y		x	y		x	y
$\beta_5 = 1^\circ 03' 39'', 7$			$R = 270$						$\beta_{100} = 21^\circ 13' 14''$		
5	5,00	0,05	30	29,94	1,66	55	54,62	5,58	80	78,83	11,77
10	10,00	19	35	34,90	2,27	60	59,51	6,64	85	83,60	13,27
15	14,99	42	40	39,85	96	65	64,37	7,79	90	88,34	14,86
20	19,98	0,74	45	44,79	3,74	70	69,22	9,02	95	93,05	16,54
25	24,96	1,16	50	49,71	4,62	75	74,04	10,35	100	97,73	18,31
$\beta_5 = 1^\circ 02' 30'', 3$			$R = 275$						$\beta_{105} = 21^\circ 52' 36''$		
5	5,00	0,05	35	34,91	2,22	60	59,53	6,52	85	83,65	13,03
10	10,00	18	40	39,86	90	65	64,40	7,65	90	88,41	14,59
15	14,99	41	45	44,80	3,67	70	69,25	8,86	95	93,12	16,25
20	19,98	0,72	50	49,72	4,53	75	74,07	10,16	100	97,82	17,98
25	24,97	1,14	55	54,63	5,48	80	78,88	11,55	105	102,47	19,80
30	29,94	63									
$\beta_5 = 1^\circ 01' 23'', 3$			$R = 280$						$\beta_{105} = 21^\circ 29' 09''$		
5	5,00	0,04	35	34,91	2,18	60	59,54	6,40	85	83,70	12,80
10	10,00	18	40	39,86	85	65	64,42	7,50	90	88,46	14,34
15	14,99	40	45	44,81	3,61	70	69,27	8,70	95	93,19	15,96
20	19,98	0,71	50	49,73	4,45	75	74,11	9,98	100	97,89	17,67
25	24,96	1,12	55	54,65	5,38	80	78,92	11,35	105	102,56	19,46
$\beta_5 = 0^\circ 59' 16'', 3$			$R = 290$						$\beta_{100} = 20^\circ 44' 42''$		
5	5,00	0,04	35	34,91	2,11	60	59,57	6,18	85	83,79	12,37
10	10,00	17	40	39,87	75	65	64,46	7,25	90	88,56	13,85
15	14,99	39	45	44,82	3,48	70	69,32	8,41	95	93,31	15,42
20	19,98	0,69	50	49,75	4,30	75	74,17	9,64	100	97,03	17,07
25	24,96	1,08	55	54,66	5,20	80	78,99	10,96	105	102,72	18,80
30	29,95	55									
$\beta_1 = 0^\circ 11' 27'', 5$			$R = 300$						$\beta_{110} = 21^\circ 43' 58''$		
1	1,00	0,00	21	20,98	0,73	41	40,87	2,80	61	60,58	6,18
2	2,00	01	22	21,98	81	42	41,86	93	62	61,56	6,38
3	3,00	02	23	22,98	0,88	43	42,85	3,08	63	62,54	59
4	4,00	0,03	24	23,97	96	44	43,84	22	64	63,52	80
5	5,00	0,04	25	24,97	1,04	45	44,83	37	65	64,49	7,01
6	6,00	06	26	25,96	1,13	46	45,82	52	66	65,47	23
7	7,00	08	27	26,96	21	47	46,81	3,67	67	66,45	45
8	8,00	0,11	28	27,96	31	48	47,80	83	68	67,43	67
9	9,00	0,14	29	28,95	1,40	49	48,78	99	69	68,40	90
10	9,99	17	30	29,95	50	50	49,77	4,16	70	69,37	8,13
11	10,99	20	31	30,94	60	51	50,76	33	71	70,34	36
12	11,99	0,24	32	31,94	1,71	52	51,74	50	72	71,31	60
13	12,99	0,28	33	32,93	81	53	52,73	4,67	73	72,28	84
14	13,99	33	34	33,93	93	54	53,72	85	74	73,25	9,09
15	14,99	38	35	34,92	2,04	55	54,70	5,03	75	74,22	33
16	15,99	0,43	36	35,92	16	56	55,68	5,21	76	75,19	58
17	16,99	0,48	37	36,91	28	57	56,66	40	77	76,16	83
18	17,99	54	38	37,90	2,40	58	57,64	59	78	77,12	10,08
19	18,99	60	39	38,89	53	59	58,62	78	79	78,09	34
20	19,99	0,67	40	39,88	2,66	60	59,60	98	80	79,06	10,60

5-jadv. davomi

K	Koordinatar		k	Koordinatar		k	Koordinatar		k	Koordinatar	
	x	y		x	y		x	y		x	y
$\beta_5 = 0^\circ 11' 27'', 5$			$R = 300$						$\beta_{110} = 21^\circ 43' 58''$		
81	80,02	10,87	89	87,71	13,11	97	95,32	15,55	104	101,93	17,85
82	80,98	11,14	90	88,66	40	98	96,27	87	105	102,87	18,19
83	81,94	41	91	89,62	70	99	97,22	16,19	106	103,81	18,54
84	82,91	68	92	90,57	14,00	100	98,16	16,51	107	104,75	89
85	83,87	96	93	91,52	30	101	99,11	84	108	105,69	19,24
86	84,83	12,24	94	92,47	61	102	100,05	17,17	109	106,62	19,59
87	85,80	53	95	93,42	92	103	100,99	17,51	110	107,55	94
88	86,76	81	96	94,37	15,23						
$\beta_{10} = 1^\circ 47' 25'', 8$			$R = 320$						$\beta_{110} = 19^\circ 41' 44''$		
10	10,00	0,16	40	39,90	2,50	70	69,44	7,63	100	98,38	15,50
20	19,99	62	50	49,80	3,90	80	79,17	9,95	110	107,85	18,71
30	29,96	1,41	60	59,65	5,61	90	88,82	12,57			
$\beta_{10} = 1^\circ 45' 46'', 6$			$R = 325$						$\beta_{110} = 19^\circ 23' 33''$		
10	10,00	0,15	40	39,90	2,46	70	69,46	7,51	100	98,42	15,28
20	19,99	61	50	49,80	3,84	80	79,19	9,80	110	107,91	18,44
30	29,96	1,38	60	59,66	5,53	90	88,85	12,38			
$\beta_{10} = 1^\circ 41' 06'', 6$			$R = 340$						$\beta_{100} = 18^\circ 32' 13''$		
10	10,00	0,15	40	39,91	2,35	70	69,51	7,81	100	98,56	14,60
20	19,99	59	50	49,82	3,67	80	79,26	9,37	110	108,09	17,64
30	29,96	1,32	60	59,69	5,28	90	88,95				
$\beta_1 = 0^\circ 09' 49'', 3$			$R = 350$						$\beta_{118} = 19^\circ 19' 01''$		
1	1,00	0,00	26	25,97	97	51	51,81	71	76	75,40	8,22
2	2,00	01	27	26,97	1,04	52	52,80	3,86	77	76,38	43
3	3,00	01	28	27,96	1,12	53	53,78	4,01	78	77,36	65
4	4,00	0,02	29	28,96	20	54	54,77	16	79	78,33	8,87
5	5,00	04	30	29,96	28	55	55,76	4,31	80	79,31	9,10
6	6,00	05	31	31,95	1,37	56	56,75	47	81	80,28	33
7	7,00	0,07	32	32,94	46	57	57,73	63	82	81,26	9,56
8	8,00	09	33	33,94	55	58	58,72	4,80	83	82,23	80
9	9,00	12	34	34,94	1,65	59	59,70	96	84	83,20	10,03
10	9,99	014	35	35,93	75	60	59,7	5,13	85	84,17	10,27
11	10,99	17	36	36,93	85	61	60,69	5,30	86	85,14	51
12	11,99	21	37	37,92	1,95	62	61,67	48	87	85,11	76
13	12,99	0,24	38	38,92	2,06	63	62,66	66	88	87,07	11,01
14	13,99	28	39	39,91	17	64	64,63	5,84	89	88,04	26
15	14,99	32	40	40,91	2,28	65	64,63	6,02	90	89,01	11,51
16	15,99	0,37	41	41,91	40	66	65,61	21	91	89,98	77
17	16,99	41	42	41,90	52	67	66,59	6,40	92	90,94	12,03
18	17,99	46	43	43,89	2,64	68	67,57	59	93	91,91	12,29
19	18,99	0,52	44	44,88	76	69	68,55	78	94	92,87	55
20	19,99	57	45	45,87	89	70	69,53	6,98	95	93,84	81
21	20,98	63	46	46,86	3,02	71	70,51	6,17	96	94,80	13,08
22	21,98	0,69	47	47,85	15	72	71,49	37	97	95,76	35
23	22,98	76	48	48,84	29	73	72,47	7,58	98	96,73	63
24	23,97	82	49	49,83	3,42	74	73,45	79	99	97,69	13,91
25	24,97	0,89	50	50,82	57	75	74,42	8,00	100	98,65	14,19

8-jadv. davomi

k	Koordinatar		k	Koordinatar		k	Koordinatar		k	Koordinatar	
	x	y		x	y		x	y		x	y
$\beta_1 = 0^\circ 11' 27'', 5$			$R = 350$						$\beta_{118} = 21^\circ 43' 58''$		
101	99,61	14,47	106	104,38	15,93	111	109,15	17,45	115	112,94	18,72
102	100,57	14,76	107	105,34	16,23	112	110,10	76	116	113,88	19,05
103	101,52	15,05	108	106,29	16,53	113	111,04	18,08	117	114,83	19,38
104	102,48	15,34	109	107,25	83	114	111,99	18,40	118	115,77	19,71
105	103,43	15,63	110	108,20	17,14						
$\beta_{10} = 1^\circ 35' 29'', 6$			$R = 360$						$\beta_{120} = 19^\circ 05' 55''$		
10	10,00	0,14	40	39,92	2,22	70	69,56	6,78	100	98,72	13,80
20	19,99	56	50	49,84	3,47	80	79,34	8,85	110	108,30	16,68
30	29,97	1,25	60	59,72	4,99	90	89,07	11,19	120	117,79	19,82
$\beta_{10} = 1^\circ 31' 40'', 4$			$R = 375$						$\beta_{120} = 18^\circ 20' 05''$		
10	10,00	0,13	40	39,93	2,13	70	69,59	6,51	100	98,82	13,26
20	19,99	54	50	49,85	3,33	80	79,39	8,50	110	108,43	16,02
30	29,97	1,20	60	59,74	4,79	90	89,14	10,75	120	117,96	19,04
$\beta_{10} = 1^\circ 30' 28'', 0$			$R = 380$						$\beta_{120} = 18^\circ 05' 36''$		
10	10,00	0,13	40	39,93	2,10	70	69,60	6,43	100	98,85	13,08
20	19,99	53	50	49,86	3,28	80	79,41	8,39	110	108,47	15,81
30	29,97	1,18	60	59,75	4,73	90	89,16	10,61	120	118,02	18,79
$\beta_1 = 0^\circ 08' 35'', 7$			$R = 400$						$\beta_{127} = 18^\circ 11' 29''$		
1	1,00	0,00	27	26,98	0,91	53	52,85	3,51	79	78,49	77
2	2,00	00	28	27,98	98	54	53,84	3,64	80	79,47	97
3	3,00	01	29	28,97	1,05	55	54,83	3,78	81	80,45	8,17
4	4,00	02	30	29,97	1,12	56	55,82	91	82	81,43	37
5	5,00	03	31	30,96	1,20	57	56,81	4,05	83	82,41	58
6	6,00	05	32	31,96	28	58	57,80	4,20	84	83,38	79
7	7,00	06	33	32,96	36	59	58,79	34	85	84,36	9,00
8	8,00	08	34	33,95	45	60	59,78	49	86	85,34	21
9	9,00	10	35	34,95	53	61	60,76	64	87	86,32	9,42
10	10,00	13	36	35,94	62	62	61,75	79	88	87,29	64
11	11,00	15	37	36,94	71	63	62,74	95	89	88,27	86
12	12,00	18	38	37,94	81	64	63,73	5,11	90	89,24	10,08
13	13,00	21	39	38,93	90	65	64,72	27	91	90,22	31
14	14,00	25	40	39,93	2,00	66	65,70	43	92	91,19	53
15	15,00	28	41	40,93	10	67	66,69	5,60	93	92,16	10,76
16	16,00	32	42	41,92	21	68	67,67	77	94	93,14	99
17	17,00	36	43	42,92	31	69	68,66	94	95	94,11	11,23
18	18,00	41	44	43,91	42	70	69,64	6,11	96	95,08	46
19	19,00	45	45	44,90	53	71	70,63	28	97	96,05	70
20	19,99	50	46	45,89	65	72	71,61	45	98	97,02	95
21	20,99	55	47	46,89	76	73	72,60	6,64	99	97,99	12,19
22	21,99	61	48	47,88	88	74	73,58	82	100	98,96	44
23	22,99	66	49	48,88	3,00	75	74,56	7,01	101	99,93	12,69
24	23,98	72	50	49,87	12	76	75,54	7,20	102	100,90	94
25	24,98	78	51	50,86	25	77	76,53	39	103	101,86	13,19
26	25,98	0,85	52	51,85	3,38	78	77,51	7,58	104	102,83	13,44

8-jadv. davomi

k	Koordinatalar		k	Koordinatalar		k	Koordinatalar		k	Koordinatalar	
	x	y		x	y		x	y		x	y
$\beta_1 = 0^\circ 08' 35'' ,7$			$R = 400$						$\beta_{127} = 18^\circ 11' 29''$		
105	103,80	13.70	111	109,58	15.30	117	115,34	17.00	123	121.07	18.77
106	104,76	96	112	110,54	58	118	116,30	17.29	124	122.02	19.07
107	105,73	14.22	113	111,50	86	119	117,26	58	125	122.97	37
108	106,69	49	114	112,46	16.14	120	118,21	87	126	123.92	68
109	107,66	76	115	113,42	16.42	121	119,11	18.17	127	124.87	19.99
110	108,62	15.03	116	114,38	16.71	122	120.11	18.47			

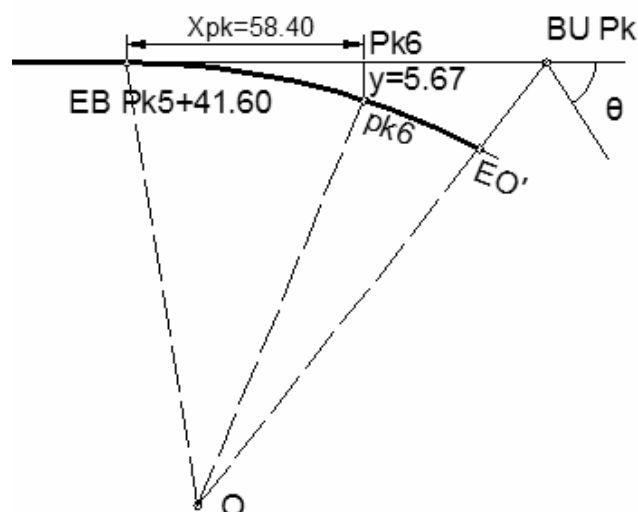

8-rasm

Jadvaldan foydalanishda quyidagicha ish tutiladi: masalan, $R=300m$, $EB=Pk\ 5 + 41.60$ bolsa, tangensga to'g'ri kelgan $Pk6$ bilan EB orasida $K_{mk} = 600 - 451,60 = 58,40m$ bo'ladi.

Jadvalning $R=300m$ dan $K = 58,40m$ uchun $X = 57,03m$ va $y = 5,67m$ interpolyatsiya yo'li bilan topiladi.

Endi $Pk6$ ni egri chiziqqa ko'chirish uchun EB dan tangens bo'ylab $x=58.03m$ masofa o'lchanib, uning oxiridan tangensga perpendikulyar ravishda $y = 5,67m$ o'lchab qo'yilib, piketning egri chiziqdagi orni topiladi.

Bepul tarqatiladi	Muharrir:	X.T. Qayumova
Nashrga ruhsat etildi 14.06.2012		Hajmi 2 b. t.
Qog'oz bichimi 60×84/16	Adadi 30 nusxa	Buyurtma № 8-2/2012
ToshTYMI bosmaxonasi	Toshkent sh., Odilxo'jayev ko'chasi, 1	