

SH. O. ALIMOV, O. R. XOLMUHAMEDOV,  
M. A. MIRZAAHMEDOV

# ALGEBRA

UMUMIY TA'LIM MAKTABLARINING  
9- SINFI UCHUN DARSLIK

*Qayta ishlangan va to'ldirilgan nashri*

*O'zbekiston Respublikasi Xalq ta'limi vazirligi  
tasdiqlagan*

«O'QITUVCHI» NASHRIYOT-MATBAA IJODIY UYI  
TOSHKENT – 2006

### Kitobdagi shartli belgilar



bilish muhim va eslab qolish foydali (yodlash shart emas) matn



masalani yechish boshlandi



masalani yechish tugadi



matematik tasdiqni asoslash yoki formulani keltirib chiqarish boshlandi



asoslash yoki formulani keltirib chiqarish tugadi



yechilishi majburiy masalalarni ajratib turuvchi belgi



murakkabroq masala



asosiy materialni ajratish



asosiy material bo'yicha bilimni tekshirish uchun mustaqil ish



sinov mashqlari – testlar

«Darsliklar aylanma jamg'armasi mablag'lari hisobidan  
DARSLIKLAR AYLANMA JAMG'ARMASI (DAJ) uchun chop etildi».

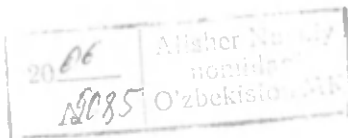

4306020502-3  
353(04)-2006 buyrt. var. – 2006

ISBN 5-645-04540-8

© «O'qituvchi» NMIU, T., 2006.

## 7-8- SINFLARDA O'RGANILGAN MAVZULARNI TAKRORLASH

*Aziz o'quvchi! Siz 7-8- sinflarda algebraik ifodalar, birhad va ko'phadlar, ko'phadni ko'paytuvchilarga ajratish, algebraik kasrlar, tengsizliklar, chiziqli funksiya va uning grafigi, ikki noma'lumli ikkita chiziqli tenglama sistemasi, taqribiy hisoblashlar, kvadrat ildizlar, kvadrat tenglamalarga doir misol va masalalarni yechgansiz. 7-8 sinflarda matematikadan olgan bilimlaringizni yodga solish maqsadida Sizga bir qator mashqlar taklif etamiz.*

1. Soddalashtiring:

1)  $(5a - 2b) - (3b - 5a)$ ;

3)  $9a - (3a + 5b) - 4b$ ;

2)  $8a - (3a - 2b) - 5b$ ;

4)  $(7a - 2b) - (3a + 4b)$ .

2. Tenglamani yeching:

1)  $4x - 6 = 12 - x$ ;

3)  $2\left(3 - \frac{x}{3}\right) = 5 + x$ ;

2)  $\frac{7x}{9} = \frac{5+x}{4}$ ;

4)  $\frac{5x-3}{2} - \frac{3-4x}{3} = \frac{2x+1}{4}$ .

3. Ko'paytuvchilarga ajrating:

1)  $4a(x + y) - 5b(x + y)$ ;

3)  $x(a - 2) + y(2 - a) + 5(2 - a)$ ;

2)  $3a(x - y) - 4(y - x)$ ;

4)  $c(p - q) + a(p - q) + d(q - p)$ .

4. Ifodani soddalashtiring:

1)  $(2a + b)^2 - (3a - b)^2$ ;

3)  $5(2 - a)^2 + 4(a - 5)^2$ ;

2)  $(a + b)^2 - (a - b)^2$ ;

4)  $(3a - y)^2 + (a - 3y)^2$ .

5. Tenglamalar sistemasini yeching:

$$\begin{cases} \frac{6y-x}{4} = 2, \\ \frac{x+13y}{2} = 4. \end{cases}$$

6. Tengsizlikni yeching:

1)  $\frac{x+4}{2} - x \leq 2 - \frac{x}{2}$ ; 2)  $3(2x - 1) + 3(x - 1) > 5(x + 2) + 2(2x - 3)$ .

7. Tengsizliklar sistemasini yeching:

$$1) \begin{cases} 2x + 5 \leq 0, \\ 9x - 18 \geq 0; \end{cases} \quad 3) \begin{cases} \frac{3(x-1)}{2} - 1,5x \geq 0, 2x - 1,5, \\ \frac{x+3}{3} > \frac{x+5}{4}; \end{cases}$$

$$2) \begin{cases} \frac{x-5}{4} \leq \frac{3x+1}{2}, \\ \frac{x+2}{3} \leq \frac{x+3}{5}; \end{cases} \quad 4) \begin{cases} 2x - 1 < 7x + 6, \\ 3x + 1 > 4x - 3, \\ 11x - 9 \leq 14x + 2. \end{cases}$$

8. Tengsizlikni yeching:

$$1) |3 - x| \leq \frac{2}{3}; \quad 2) |1 - x| \geq 1; \quad 3) |3x + 4| > 1; \quad 4) |5 - 4x| \leq 3.$$

9. Tenglamani yeching:

$$1) |x + 3| = |x - 3|; \quad 3) |x + 6| = |x + 10|;$$
$$2) |1 - x| = |x + 2|; \quad 4) |x + 5| = |x - 7|.$$

10. Hisoblang:

$$1) \frac{3}{\sqrt{11+3}} + \frac{7}{\sqrt{11-2}}; \quad 3) \frac{7}{3+\sqrt{13}} - \frac{2}{2-\sqrt{13}};$$
$$2) \frac{4}{\sqrt{7-1}} - \frac{2}{\sqrt{7+3}} - 3\sqrt{7}; \quad 4) \frac{1}{3-\sqrt{5}} + \frac{1}{2-\sqrt{5}} + \frac{3\sqrt{5}}{4}.$$

11. Tenglamani yeching:

$$1) 3x^2 - 5x + 4 = 0; \quad 3) \frac{x^2 - 3x}{7} + x = 11;$$
$$2) x^2 - 3x - 4 = 0; \quad 4) 3x(x - 2) - 1 = x - \frac{1}{2}(x^2 + 8).$$

12. Tenglamalar sistemasini yeching:

$$1) \begin{cases} 2x^2 - y^2 = 46, \\ xy = 10; \end{cases} \quad 3) \begin{cases} x^2 - y + 2 = 0, \\ x^2 + y^2 - 4 = 0; \end{cases}$$
$$2) \begin{cases} xy = 5, \\ x^2 + y^2 = 26; \end{cases} \quad 4) \begin{cases} \sqrt{x} - \sqrt{y} = 1, \\ x - y = 5. \end{cases}$$

13. Ikki sonning o'rta arifmetigi 20 ga, ularning o'rta geometrigi esa 12 ga teng. Shu sonlarni toping.

# I BOB. KVADRAT FUNKSIYA

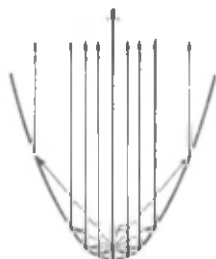

## 1-§.

## KVADRAT FUNKSIYANING TA'RIFI

Siz VIII sinfda  $y = kx + b$  chiziqli funksiya va uning grafigi bilan tanishgansiz.

Fan va texnikaning turli sohalarida *kvadrat funksiyalar* deb ataladigan funksiyalar uchraydi. Misollar keltiramiz.

1) Tomoni  $x$  bo'lgan kvadratning yuzi  $y = x^2$  formula bo'yicha hisoblanadi.

2) Agar jism yuqoriga  $v$  tezlik bilan otilgan bo'lsa, u holda  $t$  vaqtda undan Yer sirtigacha masofa  $s = -\frac{gt^2}{2} + vt + s_0$  formula bilan aniqlanadi, bunda  $s_0$  - vaqtning  $t = 0$  boshlang'ich paytidagi jismdan Yer sirtigacha bo'lgan masofa.

Bu misollarda  $y = ax^2 + bx + c$  ko'rinishdagi funksiyalar qaraldi. Birinchi misolda  $a = 1$ ,  $b = c = 0$ , o'zgaruvchilar esa  $x$  va  $y$  lar bo'ladi.

Ikkinchi misolda  $a = -\frac{g}{2}$ ,  $b = v$ ,  $c = s_0$ , o'zgaruvchilar esa  $t$  va  $s$  harflari bilan belgilangan.

**!** **Ta'rif.**  $y = ax^2 + bx + c$  funksiya kvadrat funksiya deyiladi, bunda  $a$ ,  $b$  va  $c$  — berilgan haqiqiy sonlar,  $a \neq 0$ ,  $x$  — haqiqiy o'zgaruvchi.

Masalan, quyidagi funksiyalar kvadrat funksiyalardir:

$$y = x^2,$$

$$y = -2x^2,$$

$$y = x^2 - x,$$

$$y = x^2 - 5x + 6,$$

$$y = -3x^2 + \frac{1}{2}x.$$

**1 - masala.**  $x = -2$ ,  $x = 0$ ,  $x = 3$  bo'lganda

$$y(x) = x^2 - 5x + 6$$

funksiyaning qiymatini toping.

$$\trianglequad y(-2) = (-2)^2 - 5 \cdot (-2) + 6 = 20;$$

$$y(0) = 0^2 - 5 \cdot 0 + 6 = 6;$$

$$y(3) = 3^2 - 5 \cdot 3 + 6 = 0. \blacktriangle$$

**2 - masala.**  $x$  ning qanday qiymatlarida  $y = x^2 + 4x - 5$  kvadrat funksiya: 1) 7 ga; 2) -9 ga; 3) -8 ga; 4) 0 ga teng qiymatni qabul qiladi?

$\triangle$  1) Shartga ko'ra  $x^2 + 4x - 5 = 7$ . Bu tenglamani yechib, quyidagini hosil qilamiz:

$$x^2 + 4x - 12 = 0,$$

$$x_{1,2} = -2 \pm \sqrt{4 + 12} = -2 \pm 4, \quad x_1 = 2, \quad x_2 = -6.$$

Demak,  $y(2) = 7$  va  $y(-6) = 7$ .

2) Shartga ko'ra  $x^2 + 4x - 5 = -9$ , bundan

$$x^2 + 4x + 4 = 0, \quad (x + 2)^2 = 0, \quad x = -2.$$

3) Shartga ko'ra  $x^2 + 4x - 5 = -8$ , bundan  $x^2 + 4x + 3 = 0$ .

Bu tenglamani yechib,  $x_1 = -3$ ,  $x_2 = -1$  ekanini topamiz.

4) Shartga ko'ra  $x^2 + 4x - 5 = 0$ , bundan  $x_1 = 1$ ,  $x_2 = -5$ .  $\blacktriangle$

Oxirgi holda  $x$  ning  $y = x^2 + 4x - 5$  funksiya 0 ga teng, ya'ni  $y(1) = 0$  va  $y(-5) = 0$  bo'lgan qiymatlari topildi.  $x$  ning bunday qiymatlari kvadrat funksiyaning nollari deyiladi.

**3 - masala.**  $y = x^2 - 3x$  funksiyaning nollarini toping.

$\triangle$   $x^2 - 3x = 0$  tenglamani yechib,  $x_1 = 0$ ,  $x_2 = 3$  ekanini topamiz.  $\blacktriangle$

### Mashqlar

1. (Og'zaki.) Quyida ko'rsatilgan funksiyalardan qaysilari kvadrat funksiya bo'ladi:

$$1) y = 2x^2 + x + 3;$$

$$2) y = 3x^2 - 1;$$

$$3) y = 5x + 1;$$

$$4) y = x^3 + 7x - 1;$$

$$5) y = 4x^2;$$

$$6) y = -3x^2 + 2x?$$

2.  $x$  ning shunday haqiqiy qiymatlarini topingki,  $y = x^2 - x - 3$

kvadrat funksiya: 1) -1 ga; 2) -3 ga; 3)  $-\frac{13}{4}$  ga; 4) -5 ga

teng qiymat qabul qilsin.

3.  $x$  ning qanday haqiqiy qiymatlarida  $y = -4x^2 + 3x - 1$  kvadrat funksiya: 1)  $-2$ ; 2)  $-8$ ; 3)  $-0,5$ ; 4)  $-1$  ga teng qiymat qabul qiladi?
4.  $-2$ ;  $0$ ;  $1$ ;  $\sqrt{3}$  sonlaridan qaysilari quyidagi kvadrat funksiyaning nollari bo'ladi:  
 1)  $y = x^2 + 2x$ ;                      2)  $y = x^2 + x$ ;  
 3)  $y = x^2 - 3$ ;                        4)  $y = 5x^2 - 4x - 1$ ?
5. Kvadrat funksiyaning nollarini toping:  
 1)  $y = x^2 - x$ ;                            2)  $y = x^2 + 3$ ;  
 3)  $y = 12x^2 - 17x + 6$ ;                4)  $y = -6x^2 + 7x - 2$ ;  
 5)  $y = 3x^2 - 5x + 8$ ;                6)  $y = 2x^2 - 7x + 9$ ;  
 7)  $y = 8x^2 + 8x + 2$ ;                8)  $y = \frac{1}{2}x^2 - x + \frac{1}{2}$ ;  
 9)  $y = 2x^2 + x - 1$ ;                    10)  $y = 3x^2 + 5x - 2$ .
6. Agar  $y = x^2 + px + q$  kvadrat funksiyaning  $x_1$  va  $x_2$  nollari ma'lum bo'lsa,  $p$  va  $q$  koeffitsiyentlarni toping:  
 1)  $x_1 = 2$ ,  $x_2 = 3$ ;                      2)  $x_1 = -4$ ,  $x_2 = 1$ ;  
 3)  $x_1 = -1$ ,  $x_2 = -2$ ;                4)  $x_1 = 5$ ,  $x_2 = -3$ .
7.  $x$  ning  $y = x^2 + 2x - 3$  va  $y = 2x + 1$  funksiyalar teng qiymatlar qabul qiladigan qiymatlarini toping.

## 2- §.

## $y = x^2$ FUNKSIYA

$y = x^2$  funksiyanı, ya'ni  $a = 1$ ,  $b = c = 0$  bo'lgandagi  $y = ax^2 + bx + c$  kvadrat funksiyanı qaraymiz. Bu funksiyaning grafigini yasash uchun uning qiymatlari jadvalini tuzamiz:

$x$	$-4$	$-3$	$-2$	$-1$	$0$	$1$	$2$	$3$	$4$
$y = x^2$	$16$	$9$	$4$	$1$	$0$	$1$	$4$	$9$	$16$

Jadvalda ko'rsatilgan nuqtalarnı yasab va ularni silliq egri chiziq bilan tutashtirib,  $y = x^2$  funksiyaning grafigini hosil qilamiz (1- rasm).



$y = x^2$  funksiyaning grafigi bo'lgan egri chiziq *parabola* deyiladi.

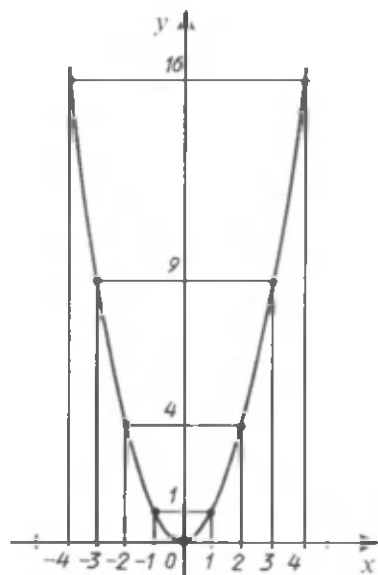

1- rasm.

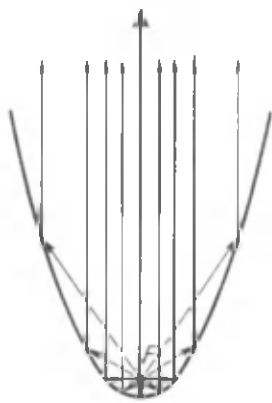

2- rasm.

$y = x^2$  funksiyaning xossalarini qaraymiz.

1)  $y = x^2$  funksiyaning qiymati  $x \neq 0$  bo'lganda *musbat* va  $x = 0$  bo'lganda *nolga* teng. Demak,  $y = x^2$  parabola koordinatalar boshidan o'tadi, parabolaning qolgan nuqtalari esa absissalar o'qidan yuqorida yotadi.  $y = x^2$  parabola absissalar o'qiga  $(0; 0)$  nuqtada urinadi, deyiladi.

2)  $y = x^2$  funksiyaning grafigi *ordinatalar o'qiga nisbatan simmetrik*, chunki  $(-x)^2 = x^2$ . Masalan,  $y(-3) = y(3) = 9$  (1- rasm). Shunday qilib, ordinatalar o'qi *parabolaning simmetriya o'qi* bo'ladi. Parabolaning o'z simmetriya o'qi bilan kesishish nuqtasi *parabolaning uchi* deyiladi.  $y = x^2$  parabola uchun koordinatalar boshi uning uchi bo'ladi.

3)  $x \geq 0$  bo'lganda  $x$  ning katta qiymatiga  $y$  ning katta qiymati mos keladi. Masalan,  $y(3) > y(2)$ .  $y = x^2$  funksiya  $x \geq 0$  oraliqda *o'suvchi*, deyiladi (1- rasm).

$x \leq 0$  bo'lganda  $x$  ning katta qiymatiga  $y$  ning kichik qiymati mos keladi. Masalan,  $y(-2) < y(-4)$ .  $y = x^2$  funksiya  $x \leq 0$  oraliqda *kamayuvchi* deyiladi (1- rasm).

**Masala.**  $y = x^2$  parabola bilan  $y = x + 6$  to'g'ri chiziqning kesishish nuqtalari koordinatalarini toping.



### △ Kesishish nuqtalari

$$\begin{cases} y = x^2, \\ y = x + 6 \end{cases}$$

sistemaning yechimlari bo'ladi.

Bu sistemadan  $x^2 = x + 6$ , ya'ni  $x^2 - x - 6 = 0$  ni hosil qilamiz, bundan  $x_1 = 3$ ,  $x_2 = -2$ .  $x_1$  va  $x_2$  ning qiymatlarini sistemaning tenglamalaridan biriga qo'yib,  $y_1 = 9$ ,  $y_2 = 4$  ni topamiz.

**Javob:** (3; 9), (-2; 4). ▲

Parabola texnikada keng ko'lamda foydalaniladigan ko'pgina ajoyib xossalarga ega. Masalan, parabolaning simmetriya o'qida *parabolaning fokusi* deb ataladigan  $F$  nuqta bor (2- rasm). Agar bu nuqtada yorug'lik manbai joylashgan bo'lsa, u holda paraboladan akslangan barcha yorug'lik nurlari parallel bo'ladi. Bu xossadan proyektorlar, lokatorlar va boshqa asboblarda tayyorlashda foydalaniladi.

$y = x^2$  parabolaning fokusi  $\left(0; \frac{1}{4}\right)$  nuqta bo'ladi.

### Mashqlar

8.  $y = x^2$  funksiyaning grafigini millimetrli qog'ozda yasang. Grafik bo'yicha:
- 1)  $x = 0,8$ ;  $x = 1,5$ ;  $x = 1,9$ ;  $x = -2,3$ ;  $x = -1,5$  bo'lganda  $y$  ning qiymatini taqriban toping;
  - 2) agar  $y = 2$ ;  $y = 3$ ;  $y = 4,5$ ;  $y = 6,5$  bo'lsa,  $x$  ning qiymatini taqriban toping.
9.  $y = x^2$  funksiya grafigini yasamasdan:  $A(2; 6)$ ,  $B(-1; 1)$ ,  $C(12; 144)$ ,  $D(-3; -9)$  nuqtalardan qaysilari parabolaga tegishli bo'lishini aniqlang.
10. (Og'zaki.)  $A(3; 9)$ ,  $B(-5; 25)$ ,  $C(4; 15)$ ,  $D(\sqrt{3}; 3)$  nuqtalarga ordinatalar o'qiga nisbatan simmetrik bo'lgan nuqtalarni toping. Bu nuqtalar  $y = x^2$  funksiyaning grafigiga tegishli bo'ladimi?
11. (Og'zaki.)  $y = x^2$  funksiyaning qiymatlarini
- 1)  $x = 2,5$  va  $x = 3\frac{1}{3}$ ;
  - 2)  $x = 0,4$  va  $x = 0,3$ ;
  - 3)  $x = -0,2$  va  $x = -0,1$ ;
  - 4)  $x = 4,1$  va  $x = -5,2$
- bo'lganda taqqoslang.

12.  $y = x^2$  parabolaning:

- 1)  $y = 25$ ;                      2)  $y = 5$ ;                      3)  $y = -x$ ;  
4)  $y = 2x$ ;                      5)  $y = 3 - 2x$ ;                      6)  $y = 2x - 1$

to'g'ri chiziq bilan kesishish nuqtalarining koordinatalarini toping.

13. A nuqta  $y = x^2$  parabola bilan

- 1)  $y = -x - 6$ ,  $A(-3; 9)$ ;                      2)  $y = 5x - 6$ ,  $A(2; 4)$

to'g'ri chiziqning kesishish nuqtasi bo'ladimi?

14. Tasdiq to'g'rimi:  $y = x^2$  funksiya:

- 1)  $[1; 4]$  kesmada;                      2)  $(2; 5)$  intervalda;  
3)  $x > 3$  intervalda;                      4)  $[-3; 4]$  kesmada o'sadi?

15. Bitta koordinata tekisligida  $y = x^2$  parabola bilan  $y = 3$  to'g'ri chiziqni yasang.  $x$  ning qanday qiymatlarida parabolaning nuqtalari to'g'ri chiziqdan yuqorida bo'ladi; pastda bo'ladi?

16.  $x$  ning qanday qiymatlarida  $y = x^2$  funksiyaning qiymati:

- 1) 9 dan katta;    2) 25 dan katta emas;    3) 16 dan kichik emas;  
4) 36 dan kichik bo'ladi?

### 3- §.

### $y = ax^2$ FUNKSIYA

**1-masala.**  $y = 2x^2$  funksiyaning grafigini yasang.

△  $y = 2x^2$  funksiyaning qiymatlar jadvalini tuzamiz:

$x$	-3	-2	-1	0	1	2	3
$y = 2x^2$	18	8	2	0	2	8	18

Topilgan nuqtalarni yasaymiz va ular orqali silliq egri chiziq o'tkazamiz (3- rasm). ▲

$y = 2x^2$  va  $y = x^2$  funksiyalarning grafiklarini taqqoslaymiz (3- rasm).  $x$  ning aynan bir qiymatida  $y = 2x^2$  funksiyaning qiymati  $y = x^2$  funksiyaning qiymatidan 2 marta ortiq. Bu  $y = 2x^2$  funksiya grafigining har bir nuqtasini  $y = x^2$  funksiya grafigining xuddi shunday absissali nuqtasining ordinatasini 2 marta orttirish bilan hosil qilish mumkinligini bildiradi.

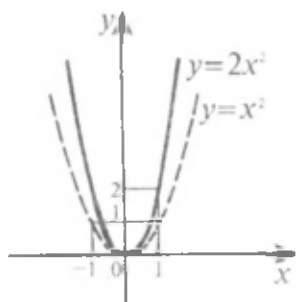

3- rasm.

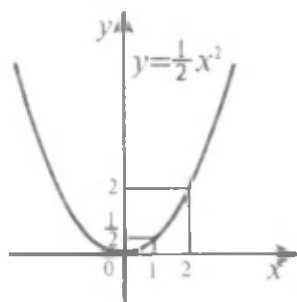

4- rasm.

$y = 2x^2$  funksiyaning grafigi  $y = x^2$  funksiya grafigini  $Ox$  o'qidan  $Oy$  o'qi bo'yicha 2 marta *cho'zish* bilan hosil qilinadi, deyiladi.

**2- masala.**  $y = \frac{1}{2}x^2$  funksiyaning grafigini yasang.

$\Delta y = \frac{1}{2}x^2$  funksiyaning qiymatlar jadvalini tuzamiz:

$x$	-3	-2	-1	0	1	2	3
$y = \frac{1}{2}x^2$	4,5	2	0,5	0	0,5	2	4,5

Topilgan nuqtalarni yasab, ular orqali silliq egri chiziq o'tkazamiz (4- rasm). ▲

$y = \frac{1}{2}x^2$  va  $y = x^2$  funksiyalarning grafiklarini taqqoslaymiz.

$y = \frac{1}{2}x^2$  funksiya grafigining har bir nuqtasini  $y = x^2$  funksiya grafigining xuddi shunday absissali nuqtasining ordinatasini 2 marta kamaytirish bilan hosil qilish mumkin.

$y = \frac{1}{2}x^2$  funksiyaning grafigi  $y = x^2$  funksiya grafigini  $Ox$  o'qiga  $Oy$  o'qi bo'yicha 2 marta *siqish* yo'li bilan hosil qilinadi, deyiladi.

**3- masala.**  $y = -x^2$  funksiyaning grafigini yasang.

$\Delta y = -x^2$  va  $y = x^2$  funksiyalarni taqqoslaymiz.  $x$  ning aynan bir qiymatida bu funksiyalarning qiymatlari modullari bo'yicha teng va

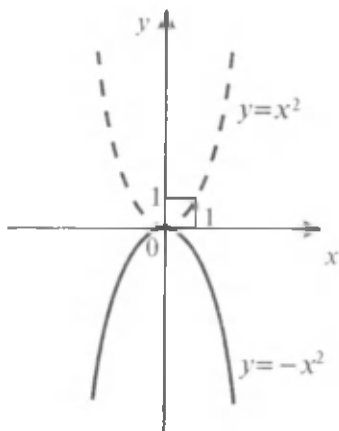

5- rasm.

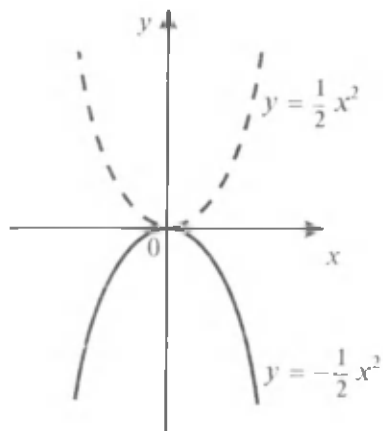

6- rasm.

qarama-qarshi ishorali. Demak,  $y = -x^2$  funksiyaning grafigini  $y = x^2$  funksiya grafigini  $Ox$  o'qiga nisbatan simmetik ko'chirish bilan hosil qilish mumkin (5- rasm). ▲

Shunga o'xshash,  $y = -\frac{1}{2}x^2$  funksiyaning grafigi  $Ox$  o'qiga nisbatan

$y = \frac{1}{2}x^2$  funksiya grafigiga simmetrikdir (6- rasm).



$y = ax^2$  funksiyaning grafigi istalgan  $a \neq 0$  da ham *parabola* deb ataladi.  $a > 0$  da parabolaning tarmoqlari *yuqoriga*,  $a < 0$  da esa *pastga yo'nalgan*.

$y = ax^2$  parabolaning fokusi  $\left(0; \frac{1}{4a}\right)$  nuqtada joylashganligini ta'kidlaymiz.

$y = ax^2$  funksiyaning asosiy xossalarini sanab o'tamiz, bunda  $a \neq 0$ .

1) agar  $a > 0$  bo'lsa, u holda  $y = ax^2$  funksiya  $x \neq 0$  bo'lganda musbat qiymatlar qabul qiladi;

agar  $a < 0$  bo'lsa, u holda  $y = ax^2$  funksiya  $x \neq 0$  bo'lganda manfiy qiymatlar qabul qiladi;

$y = ax^2$  funksiyaning qiymati faqat  $x = 0$  bo'lgandagina 0 ga teng bo'ladi.

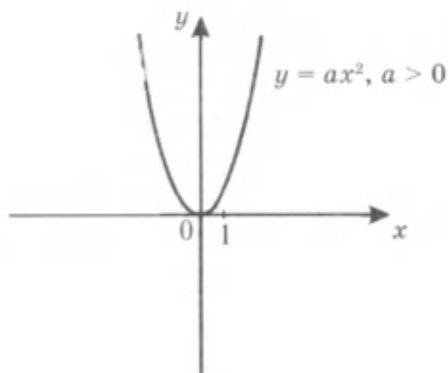

7- rasm.

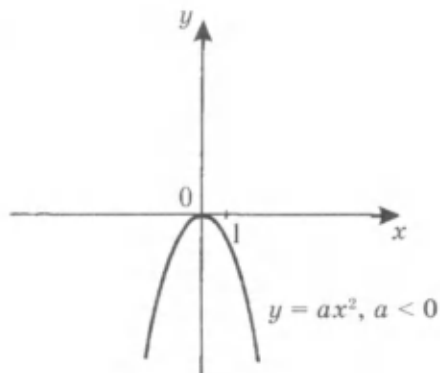

8- rasm.

2)  $y = ax^2$  parabola ordinatalar o'qiga nisbatan simmetrik bo'ladi.

3) agar  $a > 0$  bo'lsa, u holda  $y = ax^2$  funksiya  $x \geq 0$  bo'lganda o'sadi va  $x \leq 0$  bo'lganda kamayadi;

agar  $a < 0$  bo'lsa, u holda  $y = ax^2$  funksiya  $x \geq 0$  bo'lganda kamayadi va  $x \leq 0$  bo'lganda o'sadi.

Bu barcha xossalarni grafikdan ayoniy ko'rish mumkin (7- va 8- rasmlar).

### Mashqlar

17. Millimetrli qog'ozda  $y = 3x^2$  funksiyaning grafigini yasang. Grafik bo'yicha:

1)  $x = -2,8; -1,2; 1,5; 2,5$  bo'lganda  $y$  ning qiymatini toping;

2) agar  $y = 9; 6; 2; 8; 1,3$  bo'lsa,  $x$  ning qiymatini taqriban toping.

18. (Og'zaki.) Parabola tarmoqlarining yo'nalishini aniqlang:

1)  $y = 3x^2$ ; 2)  $y = \frac{1}{3}x^2$ ; 3)  $y = -4x^2$ ; 4)  $y = -\frac{1}{3}x^2$ .

19. Quyidagi funksiyalarning grafiklarini bitta koordinata tekisligida yasang:

1)  $y = x^2$  va  $y = 3x^2$ ; 2)  $y = -x^2$  va  $y = -3x^2$ ;

3)  $y = 3x^2$  va  $y = -3x^2$ ; 4)  $y = \frac{1}{3}x^2$  va  $y = -\frac{1}{3}x^2$ .

Grafiklardan foydalanib, bu funksiyalardan qaysilari  $x \geq 0$  oraliqda o'suvchi ekanini aniqlang.

20. Quyidagi funksiyalar grafiklari kesishish nuqtalarining koordinatalarini toping:

1)  $y = 2x^2$  va  $y = 3x + 2$ ;    2)  $y = -\frac{1}{2}x^2$  va  $y = \frac{1}{2}x - 3$ .

21. Funksiya  $x \leq 0$  oraliqda kamayuvchi bo'ladimi:

1)  $y = 4x^2$ ;    2)  $y = \frac{1}{4}x^2$ ;    3)  $y = -5x^2$ ;    4)  $y = -\frac{1}{5}x^2$ ?

22.  $y = -2x^2$  funksiya:

- 1)  $[-4; -2]$  kesmada;    3)  $(3; 5)$  intervalda;  
 2)  $[-5; 0]$  kesmada;    4)  $(-3; 2)$  intervalda  
 o'suvchi yoki kamayuvchi bo'lishini aniqlang.

23. Tekis tezlanuvchan harakatda jism bosib o'tgan yo'l  $s = \frac{at^2}{2}$  formula bilan hisoblanadi, bunda  $s$  — yo'l, metrlarda;  $a$  — tezlanish, m/s<sup>2</sup> larda;  $t$  — vaqt, sekundlarda o'lchanadi. Agar jism 8 s da 96 m yo'lni bosib o'tgan bo'lsa,  $a$  tezlanishni toping.

**4- §.**

**$y = ax^2 + bx + c$  FUNKSIYA**

**1- masala.**  $y = x^2 - 2x + 3$  funksiyaning grafigini yasang va uni  $y = x^2$  funksiya grafigi bilan taqqoslang.

$\Delta$   $y = x^2 - 2x + 3$  funksiyaning qiymatlar jadvalini tuzamiz:

$x$	-3	-2	-1	0	1	2	3
$y = x^2 - 2x + 3$	18	11	6	3	2	3	6

Topilgan nuqtalarni yasaymiz va ular orqali silliq egri chiziq o'tkazamiz (9- rasm).

Grafiklarni taqqoslash uchun to'la kvadratni ajratish usulidan foydalanib,  $y = x^2 - 2x + 3$  formulaning shaklini almashtiramiz:

$$y = x^2 - 2x + 1 + 2 = (x - 1)^2 + 2.$$

Avval  $y = x^2$  va  $y = (x - 1)^2$  funksiyalarning grafiklarini taqqoslaymiz. Agar  $(x_1; y_1)$  nuqta  $y = x^2$  parabolaning nuqtasi, ya'ni  $y_1 = x_1^2$  bo'lsa,

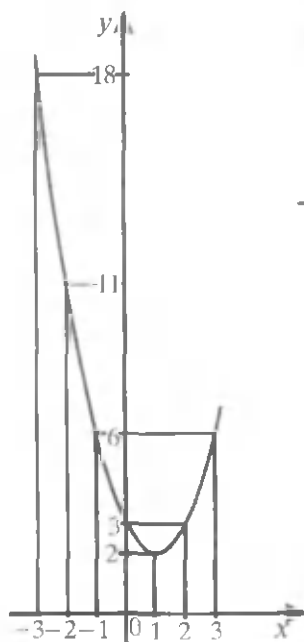

9- rasm.

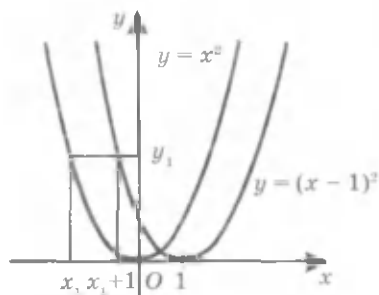

10- rasm.

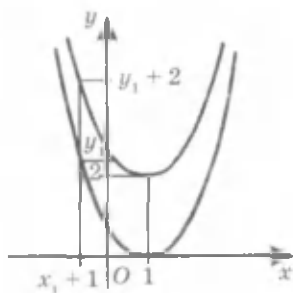

11- rasm.

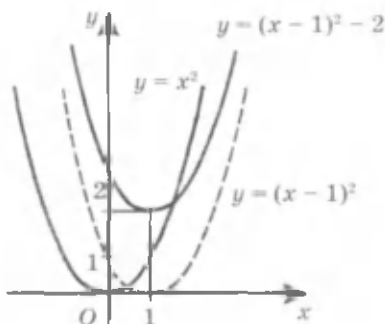

12- rasm.

u holda  $(x_1 + 1; y_1)$  nuqta  $y = (x-1)^2$  funksiyaning grafigiga tegishli bo'ladi, chunki  $((x_1 + 1) - 1)^2 = x_1^2 = y_1$ . Demak,  $y = (x-1)^2$  funksiyaning grafigi  $y = x^2$  paraboladan uni bir birlik o'ngga siljitish (parallel ko'chirish) bilan hosil qilingan parabola bo'ladi (10- rasm).

Endi  $y = (x-1)^2$  va  $y = (x-1)^2 + 2$  funksiyalarning grafiklarini taqqoslaymiz.  $x$  ning har bir qiymatida  $y = (x-1)^2 + 2$  funksiyaning qiymati  $y = (x-1)^2$  funksiyaning qiymatidan 2 taga ortiq. Demak,  $y = (x-1)^2 + 2$  funksiyaning grafigi  $y = (x-1)^2$  parabolani ikki birlik yuqoriga siljitish bilan hosil qilingan parabola bo'ladi (11- rasm).

Shunday qilib,  $y = x^2 - 2x + 3$  funksiyaning grafigi  $y = x^2$  parabolani bir birlik o'ngga va ikki birlik yuqoriga siljitish natijasida hosil qilingan parabola bo'ladi (12- rasm).  $y = x^2 - 2x + 3$  parabolaning simmetriya o'qi ordinatalar o'qiga parallel va parabolaning uchi bo'lgan  $(1; 2)$  nuqtadan o'tgan to'g'ri chiziq bo'ladi. ▲

$y = a(x - x_0)^2 + y_0$  funksiyaning grafigi  $y = ax^2$  parabolani:

agar  $x_0 > 0$  bo'lsa, absissalar o'qi bo'yicha o'ngga  $x_0$  ga, agar  $x_0 < 0$  bo'lsa, chapga  $|x_0|$  ga siljitish;

agar  $y_0 > 0$  bo'lsa, ordinatalar o'qi bo'ylab yuqoriga  $y_0$  ga, agar  $y_0 < 0$  bo'lsa, pastga  $|y_0|$  ga siljitish yo'li bilan hosil qilinadigan parabola bo'lishi shunga o'xshash isbot qilinadi.

Istalgan  $y = ax^2 + bx + c$  kvadrat funksiyani undan to'la kvadratni ajratish yordamida

$$y = a \left( x + \frac{b}{a} \right)^2 - \frac{b^2 - 4ac}{4a},$$

ya'ni  $y = a(x - x_0)^2 + y_0$  kabi ko'rinishda yozish mumkin, bunda

$$x_0 = -\frac{b}{2a}, y_0 = y(x_0) = \frac{b^2 - 4ac}{4a}.$$

Shunday qilib,  $y = ax^2 + bx + c$  funksiyaning grafigi  $y = ax^2$  parabolani koordinatalar o'qlari bo'ylab siljitishlar natijasida hosil bo'ladigan parabola bo'ladi.  $y = ax^2 + bx + c$  tenglik parabolaning tenglamasi deyiladi.  $y = ax^2 + bx + c$  parabola uchining  $(x_0; y_0)$  koordinatalarini quyidagi formula bo'yicha topish mumkin:

$$x_0 = -\frac{b}{2a}, y_0 = y(x_0) = ax_0^2 + bx_0 + c.$$

$y = ax^2 + bx + c$  parabolaning simmetriya o'qi ordinatalar o'qiga parallel va parabolaning uchidan o'tuvchi to'g'ri chiziq bo'ladi.

$y = ax^2 + bx + c$  parabolaning tarmoqlari, agar  $a > 0$  bo'lsa, yuqoriga yo'nalgan, agar  $a < 0$  bo'lsa, pastga yo'nalgan bo'ladi.

**2-masala.**  $y = 2x^2 - x - 3$  parabola uchining koordinatalarini toping.

△ Parabola uchining absissasi:

$$x_0 = -\frac{b}{2a} = \frac{1}{4}.$$

Parabola uchining ordinatasi:

$$y_0 = ax_0^2 + bx_0 + c = 2 \cdot \frac{1}{16} - \frac{1}{4} - 3 = -3\frac{1}{8}.$$

**J a v o b :**  $\left( \frac{1}{4}; -3\frac{1}{8} \right)$ . ▲



**3-masala.** Agar parabolaning  $(-2; 5)$  nuqta orqali o'tishi va uning uchi  $(-1; 2)$  nuqtada bo'lishi ma'lum bo'lsa, parabolaning tenglamasini yozing.

△ Parabolaning uchi  $(-1; 2)$  nuqta bo'lgani uchun parabolaning tenglamasini quyidagi ko'rinishda yozish mumkin:

$$y = a(x + 1)^2 + 2.$$

Shartga ko'ra  $(-2; 5)$  nuqta parabola tegishli va, demak,

$$5 = a(-2 + 1)^2 + 2,$$

bundan  $a = 3$ .

Shunday qilib, parabola

$$y = 3(x + 1)^2 + 2 \text{ yoki } y = 3x^2 + 6x + 5$$

tenglama bilan beriladi. ▲

### Mashqlar

Parabola uchining koordinatalarini toping (24–26):

24. (Oq'zaki.)

1)  $y = (x - 3)^2 - 2;$

2)  $y = (x + 4)^2 + 3;$

3)  $y = 5(x + 2)^2 - 7;$

4)  $y = -4(x - 1)^2 + 5.$

25. 1)  $y = x^2 + 4x + 1;$

2)  $y = x^2 - 6x - 7;$

3)  $y = 2x^2 - 6x + 11;$

4)  $y = -3x^2 + 18x - 7.$

26. 1)  $y = x^2 + 2;$

2)  $y = -x^2 - 5;$

3)  $y = 3x^2 + 2x;$

4)  $y = -4x^2 + x.$

27.  $Ox$  o'qida shunday nuqtani topingki, undan parabolaning simmetriya o'qi o'tsin:

1)  $y = x^2 + 3;$

2)  $y = (x + 2)^2;$

3)  $y = -3(x + 2)^2 + 2;$

4)  $y = (x - 2)^2 + 2;$

5)  $y = x^2 + x + 1;$

6)  $y = 2x^2 - 3x + 5.$

28.  $y = x^2 - 10x$  parabolaning simmetriya o'qi: 1)  $(5; 10)$ ; 2)  $(3; -8)$ ; 3)  $(5; 0)$ ; 4)  $(-5; 1)$  nuqtadan o'tadimi?

29. Parabolaning koordinatalar o'qlari bilan kesishish nuqtalarining koordinatalarini toping:

1)  $y = x^2 - 3x + 2;$

2)  $y = -2x^2 + 3x - 1;$

3)  $y = 3x^2 - 7x + 12;$

4)  $y = 3x^2 - 4x.$

30. Agar parabolaning  $(-1; 6)$  nuqta orqali o'tishi va uning uchi  $(1; 2)$  nuqta ekanligi ma'lum bo'lsa, parabolaning tenglamasini yozing.

31. (Og'zaki.)  $(1; -6)$  nuqta  $y = -3x^2 + 4x - 7$  parabola ga tegishli bo'ladimi?

32. Agar  $(-1; 2)$  nuqta: 1)  $y = kx^2 + 3x - 4$ ; 2)  $y = -2x^2 + kx - 6$  parabola ga tegishli bo'lsa,  $k$  ning qiymatini toping.

33.  $y = x^2$  parabola andazasi yordamida funksiyaning grafigini yasang:

1)  $y = (x + 2)^2$ ;    2)  $y = (x - 3)^2$ ;    3)  $y = x^2 - 2$ ;  
4)  $y = -x^2 + 1$ ;    5)  $y = -(x - 1)^2 - 3$ ;    6)  $y = (x + 2)^2 + 1$ .

34.  $y = 2x^2$  parabola dan uni:

- 1)  $Ox$  o'qi bo'yicha 3 birlik o'ngga siljitish;
- 2)  $Oy$  o'qi bo'yicha 4 birlik yuqoriga siljitish;
- 3)  $Ox$  o'qi bo'yicha 2 birlik chapga va keyin  $Oy$  o'qi bo'yicha bir birlik pastga siljitish;
- 4)  $Ox$  o'qi bo'yicha 1,5 birlik o'ngga va keyin  $Oy$  o'qi bo'yicha 3,5 birlik yuqoriga siljitish  
natijasida hosil bo'lgan parabolaning tenglamasini yozing.

## 5-§. KVADRAT FUNKSIYANING GRAFIGINI YASASH

**1-masala.**  $y = x^2 - 4x + 3$  funksiyaning grafigini yasang.

△ 1. Parabola uchining koordinatalarini hisoblaymiz:

$$x_0 = -\frac{-4}{2} = 2,$$
$$y_0 = 2^2 - 4 \cdot 2 + 3 = -1.$$

$(2; -1)$  nuqtani yasaymiz.

2.  $(2; -1)$  nuqta orqali ordinatalar o'qiga parallel to'g'ri chiziq, ya'ni parabolaning simmetriya o'qini o'tkazamiz (13- a rasm).

3. Ushbu

$$x^2 - 4x + 3 = 0$$

tenglamani yechib, funksiyaning nollarini topamiz:  $x_1 = 1$ ,  $x_2 = 3$ .  
 $(1; 0)$  va  $(3; 0)$  nuqtalarni yasaymiz (13- b rasm).

4.  $Ox$  o'qida  $x = 2$  nuqtaga nisbatan simmetrik bo'lgan ikkita nuqtani, masalan,  $x = 0$  va  $x = 4$  nuqtalarni olamiz. Funktsiyaning bu nuqtalardagi qiymatlarini hisoblaymiz:  $y(0) = y(4) = 3$ .

(0; 3) va (4; 3) nuqtalarni yasaymiz (13- b rasm).

5. Yasalغان nuqtalar orqali parabolanı o'tkazamiz (13- d rasm). ▲

Shu yo'sında istalgan  $y = ax^2 + bx + c$  kvadrat funktsiyaning grafigini yasash mumkin:

1.  $x_0, y_0$  larni  $x_0 = -\frac{b}{2a}$ ,  $y_0 = y(x_0)$  formulalardan foydalanib hisoblab, parabolaning ( $x_0; y_0$ ) uchi yasaladi.

2. Parabolaning uchidan ordinatalar o'qiga parallel to'g'ri chiziq – parabolaning simmetriya o'qi o'tkaziladi.

3. Funktsiyaning nollari (agar ular mavjud bo'lsa) topiladi va absissalar o'qida parabolaning mos nuqtalari yasaladi.

4. Parabolaning uning o'qiga nisbatan simmetrik bo'lgan qandaydir ikkita nuqtasi yasaladi. Buning uchun  $Ox$  o'qida  $x_0$  ( $x_0 \neq 0$ ) nuqtaga nisbatan simmetrik bo'lgan ikkita nuqta olish va funktsiyaning mos qiymatlarini (bu qiymatlar bir xil) hisoblash kerak. Masalan, parabolaning absissalari  $x = 0$  va  $x = 2x_0$  bo'lgan nuqtalarini (bu nuqtalarning ordinatalari  $c$  ga teng) yasash mumkin.

5. Yasalغان nuqtalar orqali parabola o'tkaziladi. Grafikni yanada aniqroq yasash uchun parabolaning yana bir nechta nuqtasini topish foydali.

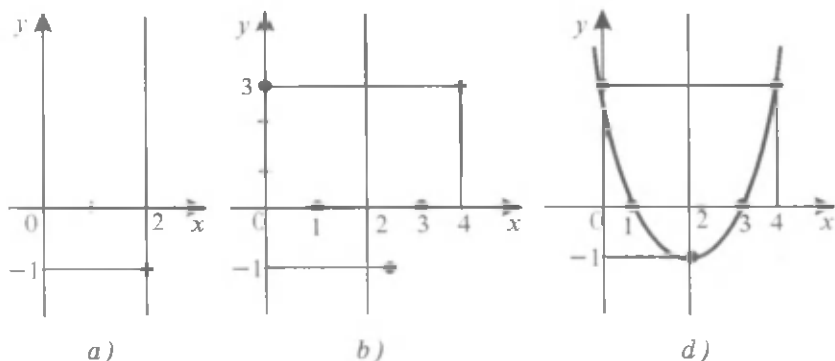

13- rasm.

**2-masala.**  $y = -2x^2 + 12x - 19$  funksiyaning grafigini yasang.

△ 1. Parabola uchining koordinatalarini hisoblaymiz:

$$x_0 = -\frac{12}{-4} = 3, \quad y_0 = -2 \cdot 3^2 + 12 \cdot 3 - 19 = -1.$$

(3; -1) nuqtani - parabolaning uchini yasaymiz (14- rasm).

2. (3; -1) nuqta orqali parabolaning simmetriya o'qini o'tkazamiz (14- rasm).

3.  $-2x^2 + 12x - 19 = 0$  tenglamani yechib, haqiqiy ildizlar yo'qligiga va shuning uchun parabola  $Ox$  o'qini kesmasligiga ishonch hosil qilamiz.

4.  $Ox$  o'qida  $x = 3$  nuqtaga nisbatan simmetrik bo'lgan ikkita nuqtani, masalan,  $x = 2$  va  $x = 4$  nuqtalarni olamiz. Funksiyaning bu nuqtalardagi qiymatlarini hisoblaymiz:

$$y(2) = y(4) = -3.$$

(2; -3) va (4; -3) nuqtalarni yasaymiz (14- rasm).

5. Yasalgan nuqtalar orqali parabola o'tkazamiz (15- rasm). ▲

**3-masala.**  $y = -x^2 + x + 6$  funksiyaning grafigini yasang va shu funksiya qanday xossalarga ega ekanini aniqlang.

△ Funksiyaning grafigini yasash uchun uning nollarini topamiz:  $-x^2 + x + 6 = 0$ , bundan  $x_1 = -2$ ,  $x_2 = 3$ . Parabola uchining koordinatalarini bunday topish mumkin:

$$x_0 = \frac{x_1 + x_2}{2} = \frac{-2 + 3}{2} = \frac{1}{2},$$

$$y_0 = y\left(\frac{1}{2}\right) = -\frac{1}{4} + \frac{1}{2} + 6 = 6\frac{1}{4}.$$

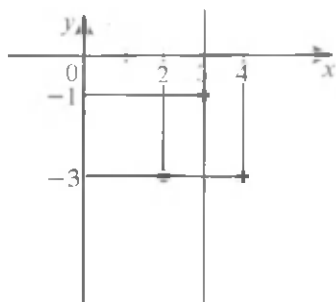

14- rasm.

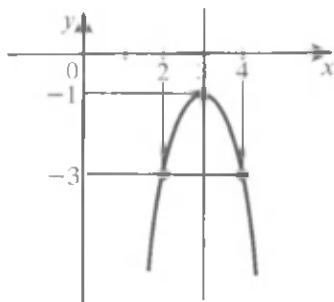

15- rasm.

$a = -1 < 0$  bo'lgani uchun parabola-ning tarmoqlari pastga yo'nalgan.

Parabolaning yana bir nechta nuqtasini topamiz:  $y(-1) = 4$ ,  $y(0) = 6$ ,  $y(1) = 6$ ,  $y(2) = 4$ . Parabolani yasaymiz (16- rasm).

Grafik yordamida  $y = -x^2 + x + 6$  funksiyaning quyidagi xossalari hosil qilamiz:

1)  $x$  ning istalgan qiymatlarida funksiyaning qiymatlari  $6\frac{1}{4}$  ga teng yoki undan kichik;

2)  $-2 < x < 3$  da funksiyaning qiymatlari musbat,  $x < -2$  da va  $x > 3$  da manfiy,  $x = -2$  va  $x = 3$  da nolga teng;

3) funksiya  $x \leq \frac{1}{2}$  oraliqda o'sadi,

$x \geq \frac{1}{2}$  oraliqda kamayadi;

4)  $x = \frac{1}{2}$  bo'lganda funksiya  $6\frac{1}{4}$  ga teng bo'lgan eng katta qiymatini qabul qiladi;

5) funksiyaning grafigi  $x = \frac{1}{2}$  to'g'ri chiziqqa nisbatan simmetrik. ▲

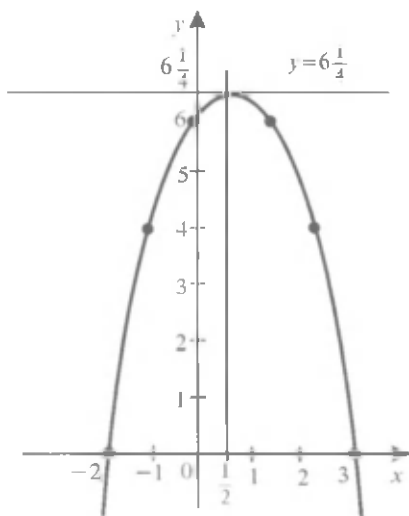

16- rasm.

$y = ax^2 + bx + c$  funksiya  $x_0 = -\frac{b}{2a}$  nuqtada eng kichik yoki eng katta qiymatlarni qabul qiladi; bu  $x_0$  nuqta parabola uchining absissasidir.

Funksiyaning  $x_0$  nuqtadagi qiymatini  $y_0 = y(x_0)$  formula bo'yicha topish mumkin. Agar  $a > 0$  bo'lsa, u holda funksiya eng kichik qiymatga ega bo'ladi, agar  $a < 0$  bo'lsa, u holda funksiya eng katta qiymatga ega bo'ladi.

Masalan,  $y = x^2 - 4x + 3$  funksiya  $x = 2$  bo'lganda  $-1$  ga teng bo'lgan eng kichik qiymatini qabul qiladi (13- d rasm);  $y = -2x^2 + 12x - 9$  funksiya  $x = 3$  bo'lganda  $-1$  ga teng bo'lgan eng katta qiymatini qabul qiladi (15- rasm).

**4-masala.** Ikkita musbat sonning yig'indisi 6 ga teng. Agar ularning kvadratlari yig'indisi eng kichik bo'lsa, shu sonlarni toping. Shu sonlar kvadratlari yig'indisining eng kichik qiymati qanday bo'ladi?

△ Birinchi sonni  $x$  harfi bilan belgilaymiz, bu holda ikkinchi son  $6 - x$ , ular kvadratlarning yig'indisi esa  $x^2 + (6 - x)^2$  bo'ladi. Bu ifodaning shaklini almashtiramiz:

$$x^2 + (6 - x)^2 = x^2 + 36 - 12x + x^2 = 2x^2 - 12x + 36.$$

Masala  $y = 2x^2 - 12x + 36$  funksiyaning eng kichik qiymatini topishga keltirildi. Shu parabola uchining koordinatlarini topamiz:

$$x_0 = -\frac{b}{2a} = -\frac{-12}{2 \cdot 2} = 3, y_0 = y(3) = 2 \cdot 9 - 12 \cdot 3 + 36 = 18.$$

Demak,  $x = 3$  bo'lganda funksiya 18 ga teng eng kichik qiymatni qabul qiladi.

Shunday qilib, birinchi son 3 ga teng, ikkinchi son ham  $6 - 3 = 3$  ga teng. Bu sonlar kvadratlari yig'indisining qiymati 18 ga teng. ▲

### Mashqlar

**35.** Parabola uchining koordinatlarini toping:

1)  $y = x^2 - 4x - 5$ ;                      2)  $y = x^2 + 3x + 5$ ;

3)  $y = -x^2 - 2x + 5$ ;                    4)  $y = -x^2 + 5x - 1$ .

**36.** Parabolaning koordinata o'qlari bilan kesishish nuqtalarining koordinatlarini toping:

1)  $y = x^2 - 3x + 5$ ;                      2)  $y = -2x^2 - 8x + 10$ ;

3)  $y = -2x^2 + 6$ ;                        4)  $y = 7x^2 + 14$ .

Funksiyaning grafigini yasang va grafik bo'yicha: 1)  $x$  ning funksiyaning qiymatlari musbat; manfiy bo'ladigan qiymatlarini toping; 2) funksiyaning o'sish va kamayish oraliqlarini toping; 3)  $x$  ning qanday qiymatlarida funksiya eng katta yoki eng kichik qiymatlar qabul qilishini aniqlang va ularni toping (**37–38**):

**37.** 1)  $y = x^2 - 7x + 10$ ;                      2)  $y = -x^2 + x + 2$ ;

3)  $y = -x^2 + 6x - 9$ ;                      4)  $y = x^2 + 4x + 5$ .

**38.** 1)  $y = 4x^2 + 4x - 3$ ;                      2)  $y = -3x^2 - 2x + 1$ ;

3)  $y = -2x^2 + 3x + 2$ ;                      4)  $y = 3x^2 - 8x + 4$ ;

5)  $y = 4x^2 + 12x + 9$ ;                      6)  $y = -4x^2 + 4x - 1$ ;

7)  $y = 2x^2 - 4x + 5$ ;                      8)  $y = -3x^2 - 6x - 4$ .

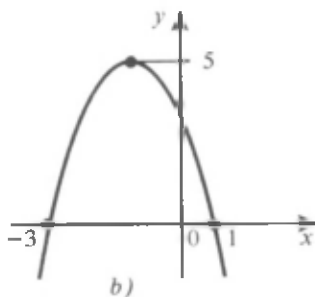
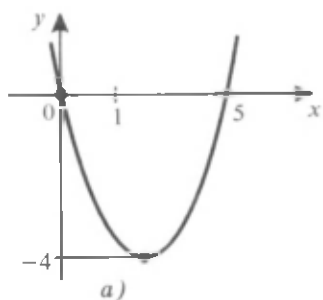

17- rasm.

39. Kvadrat funksiyaning berilgan grafigi (17- rasm) bo'yicha uning xossalarini aniqlang.

40. 15 sonni ikkita sonning yig'indisi shaklida shunday tasvirlangki, bu sonlarning ko'paytmasi eng katta bo'lsin.
41. Ikki sonning yig'indisi 10 ga teng. Agar shu sonlar kublarining yig'indisi eng kichik bo'lsa, shu sonlarni toping.
42. Uy devorlariga yondashgan to'g'ri to'rtburchak shaklidagi maydonni uch tomonidan 12 m li panjara bilan o'rab olish talab etiladi. Maydonning o'lchamlari qanday bo'lganda uning yuzi eng katta bo'ladi?
43. Uchburchakda asosi bilan shu asosga tushirilgan balandlikning yig'indisi 14 sm ga teng. Shunday uchburchak  $25 \text{ sm}^2$  ga teng yuzga ega bo'lishi mumkinmi?
44. Grafikni yasamasdan,  $x$  ning qanday qiymatida funksiya eng katta (eng kichik) qiymatga ega bo'lishini aniqlang; shu qiymatni toping:
- |                          |                          |
|--------------------------|--------------------------|
| 1) $y = x^2 - 6x + 13$ ; | 2) $y = x^2 - 2x - 4$ ;  |
| 3) $y = -x^2 + 4x + 3$ ; | 4) $y = 3x^2 - 6x + 1$ . |
45. Agar:
- 1) parabolaning tarmoqlari yuqoriga yo'nalgan, uning uchining absissasi manfiy, ordinatasi esa musbat bo'lsa;
  - 2) parabolaning tarmoqlari pastga yo'nalgan, uning uchining absissa va ordinatasi manfiy bo'lsa,  $y = ax^2 + bx + c$  parabola tenglamasi koeffitsiyentlarining ishoralarini aniqlang.

46. 5 m balandlikdan kamondan 50 m/s tezlik bilan yuqoriga vertikal ravishda nayza otildi. Nayzaning  $t$  sekunddan keyin ko'tarilgan

balandligi metrlarda  $h = h(t) = 5 + 50t - \frac{gt^2}{2}$  formula bilan hisoblanadi, bunda  $g \approx 10 \text{ m/s}^2$ . Nayza necha sekunddan keyin: 1) eng katta balandlikka erishadi va u qanday balandlik bo'ladi? 2) Yerga tushadi?

### I bobga doir mashqlar

47.  $x$  ning  $y = 2x^2 - 5x + 3$  kvadrat funksiya: 1) 0 ga; 2) 1 ga; 3) 10 ga; 4) -1 ga teng qiymatlar qabul qiladigan qiymatini toping.
48. Funktsiyalar grafiklarining kesishish nuqtalari koordinatalarini toping:
- 1)  $y = x^2 - 4$  va  $y = 2x - 4$ ;
  - 2)  $y = x^2$  va  $y = 3x - 2$ ;
  - 3)  $y = x^2 - 2x - 5$  va  $y = 2x^2 + 3x + 1$ ;
  - 4)  $y = x^2 + x - 2$  va  $y = (x + 3)(x - 4)$ .
49. Tengsizlikni yeching:
- 1)  $x^2 \leq 5$ ;
  - 2)  $x^2 > 36$ .
50. Parabolaning koordinata o'qlari bilan kesishish nuqtalari koordinatalarini toping:
- 1)  $y = x^2 + x - 12$ ;
  - 2)  $y = -x^2 + 3x + 10$ ;
  - 3)  $y = -8x^2 - 2x + 1$ ;
  - 4)  $y = 7x^2 + 4x - 11$ ;
  - 5)  $y = 5x^2 + x - 1$ ;
  - 6)  $y = 5x^2 + 3x - 2$ ;
  - 7)  $y = 4x^2 - 11x + 6$ ;
  - 8)  $y = 3x^2 + 13x - 10$ .
51. Parabola uchining koordinatalarini toping:
- 1)  $y = x^2 - 4x - 5$ ;
  - 2)  $y = -x^2 - 2x + 3$ ;
  - 3)  $y = x^2 - 6x + 10$ ;
  - 4)  $y = x^2 + x + \frac{5}{4}$ ;
  - 5)  $y = -2x(x + 2)$ ;
  - 6)  $y = (x - 2)(x + 3)$ .
52. Funktsiyaning grafigini yasang va grafik bo'yicha uning xossalari aniqlang:
- 1)  $y = x^2 - 5x + 6$ ;
  - 2)  $y = x^2 + 10x + 30$ ;
  - 3)  $y = -x^2 - 6x - 8$ ;
  - 4)  $y = 2x^2 - 5x + 2$ ;
  - 5)  $y = -3x^2 - 3x + 1$ ;
  - 6)  $y = -2x^2 - 3x - 3$ .



### O'ZINGIZNI TEKSHIRIB KO'RING!

1.  $y = x^2 - 6x + 5$  funksiyaning grafigini yasang va uning eng kichik qiymatini toping.
2.  $y = -x^2 + 2x + 3$  funksiya grafigi yordamida  $x$  ning qanday qiymatida funksiyaning qiymati 3 ga teng bo'lishini toping.
3.  $y = 1 - x^2$  funksiyaning grafigi bo'yicha  $x$  ning funksiya musbat; manfiy qiymatlar qabul qiladigan qiymatlarini toping.
4.  $y = 2x^2$  funksiya qanday oraliqlarda o'sadi? Kamayadi? Shu funksiyaning grafigini yasang.
5.  $y = (x - 3)^2$  parabola uchining koordinatalarini toping va uning grafigini yasang.

53. Funksiyaning grafigini yasamasdan, uning eng katta yoki eng kichik qiymatini toping:

1)  $y = x^2 + 2x + 3$ ;

2)  $y = -x^2 + 2x + 3$ ;

3)  $y = -3x^2 + 7x$ ;

4)  $y = 3x^2 + 4x + 5$ .

54. To'g'ri to'rtburchakning perimetri 600 m. To'g'ri to'rtburchakning yuzi eng katta bo'lishi uchun uning asosi bilan balandligi qanday bo'lishi kerak?

55. To'g'ri to'rtburchak uning tomonlaridan biriga parallel bo'lgan ikkita kesma bilan uch bo'lakka bo'lingan. To'g'ri to'rtburchak perimetri bilan shu kesmalar uzunliklarining yig'indisi 1600 m ga teng. Agar to'g'ri to'rtburchakning yuzi eng katta bo'lsa, uning tomonlarini toping.

56. Agar  $y = x^2 + px + q$  kvadrat funksiya:

1)  $x = 0$  bo'lganda 2 ga teng qiymatni,  $x = 1$  bo'lganda esa 3 ga teng qiymatni qabul qilsa,  $p$  va  $q$  koeffitsiyentlarni toping;

2)  $x = 0$  bo'lganda 0 ga teng qiymatni,  $x = 2$  bo'lganda esa 6 ga teng qiymatni qabul qilsa,  $p$  va  $q$  koeffitsiyentlarni toping.

57. Agar  $y = x^2 + px + q$  parabola:

1) absissalar o'qini  $x = 2$  va  $x = 3$  nuqtalarda kessa;

2) absissalar o'qini  $x = 1$  nuqtada va ordinatalar o'qini  $y = 3$  nuqtada kessa;

3) absissalar o'qiga  $x = 2$  nuqtada urinsa,  $p$  va  $q$  larni toping.

**58.**  $x$  ning qanday qiymatlarida funksiyalar teng qiymatlar qabul qiladi:

1)  $y = x^2 + 3x + 2$  va  $y = |7 - x|$ ;

2)  $y = 3x^2 - 6x + 3$  va  $y = |3x - 3|$  ?

**59.** Agar:

1) parabolaning (0; 0), (2; 0), (3; 3) koordinatali nuqtalardan o'tishi;

2) (1; 3) nuqta parabolaning uchi bo'lishi, (-1; 7) nuqtaning esa parabola tegishli bo'lishi;

3)  $y = ax^2 + bx + c$  funksiyaning nollari  $x_1 = 1$  va  $x_2 = 3$  sonlari ekani, funksiyaning eng katta qiymati esa 2 ga teng ekani ma'lum bo'lsa,  $y = ax^2 + bx + c$  parabolani yasang.

?

### I bobga doir sinov (test) mashqlari

*Sinov mashqlarining har biriga 5 ta dan «javob» berilgan. 5 ta «javob»ning faqat bittasi to'g'ri, qolganlari esa noto'g'ri. O'quvchilardan sinov mashqlarini bajarib yoki boshqa mulohazalar yordamida ana shu to'g'ri javobni topish (uni belgilash) talab qilinadi.*

1.  $a$  ning shunday qiymatini topingki,  $y = ax^2$  parabola bilan  $y = 5x + 1$  to'g'ri chiziqning kesishish nuqtalaridan birining absissasi  $x = 1$  bo'lsin.

A)  $a = 6$ ;    B)  $a = -6$ ;    C)  $a = 4$ ;    D)  $a = -4$ ;    E)  $a = 7$ .

2.  $k$  ning shunday qiymatini topingki,  $y = -x^2$  parabola bilan  $y = kx - 6$  to'g'ri chiziqning kesishish nuqtalaridan birining absissasi  $x = 2$  bo'lsin.

A)  $k = -1$ ;    B)  $k = 1$ ;    C)  $k = 2$ ;    D)  $k = -2$ ;    E)  $k = -6$ .

3.  $b$  ning shunday qiymatini topingki,  $y = 3x^2$  parabola bilan  $y = 2x + b$  to'g'ri chiziqning kesishish nuqtalaridan birining absissasi  $x = 1$  bo'lsin.

A)  $b = 2$ ;    B)  $b = -1$ ;    C)  $b = 1$ ;    D)  $b = -2$ ;    E)  $b = 3$ .

Parabolaning koordinata o'qlari bilan kesishish nuqtalarining koordinatalarini toping (4-7):

4.  $y = x^2 - 2x + 4$ .

A) (-1; 3);    B) (3; 1);    C) (1; 3);    D) (0; 4);    E) (4; 0).

5.  $y = -x^2 - 4x - 5$ .

A) (-1; 2); B) (2; -1); C) (5; 0); D) (-5; 0); E) (0; -5).

6.  $y = 6x^2 - 5x + 1$ .

A)  $(\frac{1}{3}; 0)$ ,  $(\frac{1}{2}; 0)$ , (0; 1); B)  $(-\frac{1}{3}; 0)$ ,  $(-\frac{1}{2}; 0)$ , (1; 0);

C)  $(0; \frac{1}{3})$ ,  $(0; \frac{1}{2})$ , (0; 1); D)  $(\frac{1}{3}; 0)$ ,  $(-\frac{1}{2}; 0)$ , (0; -1);

E) to'g'ri javob berilmagan.

7.  $y = -x^2 + 6x + 7$ .

A) (-1; 0), (-7; 0), (0; -7); B) (-1; 0), (7; 0), (0; 7);

C) (1; 0), (7; 0), (0; -7); D) (-1; 2), (7; -1), (7; 0); E) (3; 16).

Parabola uchining koordinatarini toping (8-11):

8.  $y = x^2 - 4x$ .

A) (0; 4); B) (4; 2); C) (2; -4); D) (-4; 2); E) (0; -4).

9.  $y = -x^2 + 2x$ .

A) (-1; -1); B) (1; -2); C) (0; 2); D) (1; 1); E) (1; -1).

10.  $y = x^2 + 6x + 5$ .

A) (3; -4); B) (-5; -1); C) (-1; -5); D) (3; 4); E) (-3; -4).

11.  $y = -5x^2 + 4x + 1$ .

A)  $(\frac{2}{5}; \frac{9}{5})$ ; B)  $(-\frac{2}{5}; \frac{9}{5})$ ; C)  $(-\frac{9}{5}; \frac{2}{5})$ ; D) (2; 9); E) (9; 5).

12. Absissalar o'qini  $x = 1$  va  $x = 2$  nuqtalarda, ordinatalar o'qini esa

$y = \frac{1}{2}$  nuqtada kesib o'tuvchi parabolaning tenglamasini yozing.

A)  $y = \frac{1}{2}x^2 - \frac{3}{4}x + \frac{1}{2}$ ; B)  $y = \frac{1}{4}x^2 - \frac{3}{4}x + \frac{1}{2}$ ;

C)  $y = x^2 - 3x + 2$ ; D)  $y = x^2 - \frac{3}{2}x + \frac{1}{2}$ ;

E) to'g'ri javob berilmagan.

13. Absissalar o'qini  $x = -1$  va  $x = 3$  nuqtalarda, ordinatalar o'qini esa  $y = 1$  nuqtada kesib o'tuvchi parabolaning tenglamasini yozing.

A)  $y = -x^2 + 2x + 3$ ; B)  $y = -\frac{x^2}{3} + 2x + 1$ ;

C)  $y = -\frac{x^2}{3} + \frac{2}{3}x + 1$ ;      D)  $y = \frac{x^2}{3} - \frac{2}{3}x - 1$ ;

E) to'g'ri javob berilmagan.

Parabola qaysi choraklarda joylashgan? (14–18):

14.  $y = 3x^2 + 5x - 2$ .

A) I, II, III;      B) II, III, IV;      C) I, III, IV;

D) I, II, III, IV;      E) I, II, IV.

15.  $y = x^2 - 4x + 6$ .

A) I, IV;    B) II, III;    C) I, II, III, IV;    D) II, III, IV;    E) I, II.

16.  $y = -x^2 - 6x - 11$ .

A) III, IV;      B) I, II, III;      C) II, III, IV;

D) I, III, IV;      E) I, II.

17.  $y = -x^2 + 5x$ .

A) I, II, III;      B) I, III, IV;      C) I, II, III, IV;

D) II, III, IV;      E) to'g'ri javob berilmagan.

18.  $y = x^2 - 4x$ .

A) I, II, III;    B) II, III, IV;    C) I, II, IV;    D) III, IV;    E) I, II.

19. Ikki musbat sonning yig'indisi 160 ga teng. Agar shu sonlar kublarining yig'indisi eng kichik bo'lsa, shu sonlarni toping.

A) 95; 65;    B) 155; 5;    C) 75; 85;    D) 80; 80;    E) 90; 70.

20. Ikki musbat sonning yig'indisi  $a$  ga teng. Agar shu sonlar kvadratlarining yig'indisi eng kichik bo'lsa, shu sonlarni toping.

A)  $\frac{2a}{5}, \frac{3a}{5}$ ;    B)  $a^3, a^3 - a$ ;    C)  $\frac{3a}{4}, \frac{a}{4}$ ;    D)  $a^2; a - a^2$ ;    E)  $\frac{a}{2}, \frac{a}{2}$ .

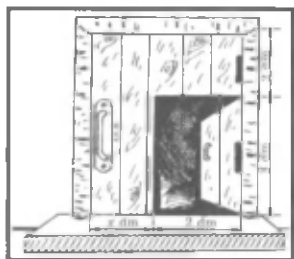

6-§.

KVADRAT TENGSIZLIK VA  
UNING YECHIMI

**1-masala.** To'g'ri to'rtburchakning tomonlari 2 dm va 3 dm ga teng. Uning har bir tomoni bir xil sondagi detsimetrlarga shunday orttirildiki, natijada to'g'ri to'rtburchakning yuzi  $12 \text{ dm}^2$  dan ortiq bo'ldi. Har bir tomon qanday o'zgartgan?

△ To'g'ri to'rtburchakning har bir tomoni  $x$  detsimetr ga orttirilgan bo'lsin. U holda yangi to'g'ri to'rtburchakning tomonlari  $(2 + x)$  va  $(3 + x)$  detsimetr ga, uning yuzi esa  $(2 + x)(3 + x)$  kvadrat detsimetr ga teng bo'ladi. Masala shartiga ko'ra  $(2 + x)(3 + x) > 12$ , bundan  $x^2 + 5x + 6 > 12$  yoki  $x^2 + 5x - 6 > 0$ .

Bu tengsizlikning chap qismini ko'paytuvchilarga ajratamiz:

$$(x + 6)(x - 1) > 0.$$

Masala shartiga ko'ra  $x > 0$  bo'lgani uchun  $x + 6 > 0$ .

Tengsizlikning ikkala qismini  $x + 6$  musbat songa bo'lib,  $x - 1 > 0$ , ya'ni  $x > 1$  ni hosil qilamiz.

**Javob:** To'g'ri to'rtburchakning har bir tomoni 1 dm dan ko'proqqa orttirilgan. ▲

$x^2 + 5x - 6 > 0$  tengsizlikda  $x$  bilan noma'lum son belgilangan. Bu - kvadrat tengsizlikka misol.

! Agar tengsizlikning chap qismida kvadrat funksiya, o'ng qismida esa nol tursa, bunday tengsizlik kvadrat tengsizlik deyiladi.

Masalan,

$$2x^2 - 3x + 1 \geq 0, -3x^2 + 4x + 5 < 0$$

tengsizliklar kvadrat tengsizliklardir.

Bir noma'lumli *tengsizlikning yechimi* deb, noma'lumning shu tengsizlikni to'g'ri sonli tengsizlikka aylantiruvchi qiymatiga aytilishini eslatib o'tamiz.

*Tengsizlikni yechish* — uning barcha yechimlarini topish yoki ularning yo'qligini ko'rsatish demakdir.

**2-masala.** Tengsizlikni yeching:

$$x^2 - 5x + 6 > 0.$$

$\Delta x^2 - 5x + 6 = 0$  kvadrat tenglama ikkita turli  $x_1 = 2$ ,  $x_2 = 3$  ildizga ega. Demak,  $x^2 - 5x + 6$  kvadrat uchhadni ko'paytuvchilarga ajratish mumkin:

$$x^2 - 5x + 6 = (x - 2)(x - 3).$$

Shuning uchun berilgan tengsizlikni bunday yozsa bo'ladi:

$$(x - 2)(x - 3) > 0.$$

Agar ikkita ko'paytuvchi bir xil ishoraga ega bo'lsa, ularning ko'paytmasi musbat ekani ravshan.

1) Ikkala ko'paytuvchi musbat, ya'ni  $x - 2 > 0$  va  $x - 3 > 0$  bo'lgan holni qaraymiz.

Bu ikki tengsizlik quyidagi sistemani tashkil qiladi:

$$\begin{cases} x - 2 > 0, \\ x - 3 > 0. \end{cases}$$

Sistemani yechib,  $\begin{cases} x > 2, \\ x > 3 \end{cases}$  ni hosil qilamiz, bundan  $x > 3$ .

Demak, barcha  $x > 3$  sonlar  $(x - 2)(x - 3) > 0$  tengsizlikning yechimlari bo'ladi.

2) Endi ikkala ko'paytuvchi manfiy, ya'ni  $x - 2 < 0$  va  $x - 3 < 0$  bo'lgan holni qaraymiz.

Bu ikki tengsizlik quyidagi sistemani tashkil qiladi:

$$\begin{cases} x - 2 < 0, \\ x - 3 < 0. \end{cases}$$

Sistemani yechib,  $\begin{cases} x < 2, \\ x < 3 \end{cases}$  ni hosil qilamiz, bundan  $x < 2$ .

Demak, barcha  $x < 2$  sonlar ham  $(x - 2)(x - 3) > 0$  tengsizlikning yechimlari bo'ladi.

Shunday qilib,  $(x - 2)(x - 3) > 0$  tengsizlikning, demak, berilgan  $x^2 - 5x + 6 > 0$  tengsizlikning ham, yechimlari  $x < 2$ , shuningdek,  $x > 3$  sonlar bo'ladi.

**J a v o b:**  $x < 2$ .  $x < 3$ . ▲

Umuman, agar  $ax^2 + bx + c = 0$  kvadrat tenglama ikkita turli ildizga ega bo'lsa, u holda  $ax^2 + bx + c > 0$  va  $ax^2 + bx + c < 0$  kvadrat tengsizliklarni yechishni, kvadrat tengsizlikning chap qismini ko'paytuvchilarga ajratib, birinchi darajali tengsizliklar sistemasini yechishga keltirish mumkin.

**3-masala.**  $-3x^2 - 5x + 2 > 0$  tengsizlikni yeching.

△ Hisoblashlarni qulayroq olib borish uchun berilgan tengsizlikni birinchi koeffitsiyenti musbat bo'lgan kvadrat tengsizliklar shaklida tasvirlaymiz. Buning uchun uning ikkala qismini  $-1$  ga ko'paytiramiz:

$$3x^2 + 5x - 2 < 0.$$

$3x^2 + 5x - 2 = 0$  tenglamaning ildizlarini topamiz:

$$x_{1,2} = \frac{-5 \pm \sqrt{25 + 24}}{6} = \frac{-5 \pm 7}{6},$$

$$x_1 = \frac{1}{3}, \quad x_2 = -2.$$

Kvadrat uchhadni ko'paytuvchilarga ajratib, quyidagini hosil qilamiz:

$$3\left(x - \frac{1}{3}\right)(x + 2) < 0.$$

Bundan ikkita sistemani olamiz:

$$\begin{cases} x - \frac{1}{3} > 0, \\ x + 2 < 0; \end{cases} \quad \begin{cases} x - \frac{1}{3} < 0, \\ x + 2 > 0. \end{cases}$$

Birinchi sistemani bunday yozish mumkin:

$$\begin{cases} x > \frac{1}{3}, \\ x < -2, \end{cases}$$

bu sistema yechimlarga ega emasligi ko'rinib turibdi.

Ikkinch sistemani yechib quyidagini topamiz:

$$\begin{cases} x < \frac{1}{3}, \\ x > -2, \end{cases}$$

bundan  $-2 < x < \frac{1}{3}$ .

Demak,  $3\left(x - \frac{1}{3}\right)(x + 2) < 0$  tengsizlikning, ya'ni  $-3x^2 - 5x + 2 > 0$

tengsizlikning yechimlari  $\left(-2; \frac{1}{3}\right)$  intervaldagi barcha sonlar bo'ladi.

**J a v o b:**  $-2 < x < \frac{1}{3}$ . ▲

### Mashqlar

60. (Og'zaki.) Quyidagi tengsizliklardan qaysilari kvadrat tengsizlik ekanini ko'rsating:

- 1)  $x^2 - 4 > 0$ ;      2)  $x^2 - 3x - 5 \leq 0$ ;      3)  $3x + 4 > 0$ ;  
4)  $4x - 5 < 0$ ;      5)  $x^2 - 1 \leq 0$ ;      6)  $x^4 - 16 > 0$ .

61. Quyidagi tengsizlikni kvadrat tengsizlikka keltiring:

- 1)  $x^2 < 3x + 4$ ;      2)  $3x^2 - 1 > x$ ;  
3)  $3x^2 < x^2 - 5x + 6$ ;      4)  $2x(x + 1) < x + 5$ .

62. (Og'zaki.) 0; -1; 2 sonlaridan qaysilari

- 1)  $x^2 + 3x + 2 > 0$ ;      2)  $-x^2 + 3,5x + 2 \geq 0$ ;  
3)  $x^2 - x - 2 \leq 0$ ;      4)  $-x^2 + x + \frac{3}{4} < 0$

tengsizlikning yechimlari bo'ladi?

Tengsizlikni yeching (63—65):

63. 1)  $(x - 2)(x + 4) > 0$ ;      2)  $(x - 11)(x - 3) < 0$ ;  
3)  $(x - 3)(x + 5) < 0$ ;      4)  $(x + 7)(x + 1) > 0$ .

64. 1)  $x^2 - 4 < 0$ ;    2)  $x^2 - 9 > 0$ ;    3)  $x^2 + 3x < 0$ ;    4)  $x^2 - 2x > 0$ .

65. 1)  $x^2 - 3x + 2 < 0$ ;    2)  $x^2 + x - 2 < 0$ ;    3)  $x^2 - 2x - 3 > 0$ ;  
4)  $x^2 + 2x - 3 > 0$ ;    5)  $2x^2 + 3x - 2 > 0$ ;    6)  $3x^2 + 2x - 1 > 0$ .



**66.** Tengsizlikni yeching:

$$1) 2 \cdot \left(x - \frac{1}{3}\right)^2 > 0;$$

$$2) 7 \cdot \left(\frac{1}{6} - x\right)^2 \leq 0;$$

$$3) 3x^2 - 3 < x^2 - x;$$

$$4) (x - 1)(x + 3) > 5.$$

**67.** Funksiyaning grafigini yasang. Grafik bo'yicha  $x$  ning funksiya musbat qiymatlar; manfiy qiymatlar; nolga teng qiymat qabul qiladigan barcha qiymatlarini toping:

$$1) y = 2x^2;$$

$$2) y = -(x + 1,5)^2;$$

$$3) y = 2x^2 - x + 2;$$

$$4) y = -3x^2 - x - 2.$$

**68.**  $x_1$  va  $x_2$  sonlar (bunda  $x_1 < x_2$ )  $y = ax^2 + bx + c$  funksiyaning nollari ekani ma'lum. Agar  $x_0$  son  $x_1$  va  $x_2$  orasida yotsa, ya'ni  $x_1 < x_0 < x_2$  bo'lsa, u holda  $a(ax_0^2 + bx_0 + c) < 0$  tengsizlik bajarilishini isbotlang.

## 7- §.

### KVADRAT TENGSIZLIKNI KVADRAT FUNKSIYA GRAFIGI YORDAMIDA YECHISH

Kvadrat funksiya  $y = ax^2 + bx + c$  (bunda  $a \neq 0$ ) formula bilan berilishini eslatib o'tamiz. Shuning uchun kvadrat tengsizlikni yechish kvadrat funksiyaning nollarini va kvadrat funksiya musbat yoki manfiy qiymatlar qabul qiladigan oraliqlarni izlashga keltiriladi.

**1-masala.** Tengsizlikni grafik yordamida yeching:

$$2x^2 - x - 1 \leq 0.$$

$\Delta y = 2x^2 - x - 1$  kvadrat funksiyaning grafigi — tarmoqlari yuqoriga yo'nalgan parabola.

Bu parabolaning  $Ox$  o'qi bilan kesishish nuqtalarini topamiz. Buning uchun  $2x^2 - x - 1 = 0$  kvadrat tenglamani yechamiz. Bu tenglamaning ildizlari:

$$x_{1,2} = \frac{1 \pm \sqrt{1+8}}{4} = \frac{1 \pm 3}{4}; x_1 = 1, x_2 = -\frac{1}{2}.$$

Demak, parabola  $Ox$  o'qini  $x = -\frac{1}{2}$  va  $x = 1$  nuqtalarda kesadi (18- rasm).

$2x^2 - x - 1 \leq 0$  tengsizlikni  $x$  ning funksiya nolga teng bo'lgan yoki funksiyaning qiymatlari manfiy bo'lgan qiymatlari qanoatlantiradi, ya'ni

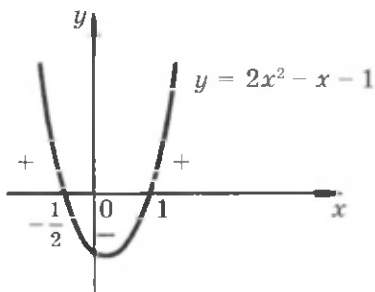

18- rasm.

$x$  ning shunday qiymatlariki, bu qiymatlarda parabolaning nuqtalari  $Ox$  o'qida yoki shu o'qdan pastda yotadi. 18- rasmdan ko'rib

turibdiki, bu qiymatlar  $\left[-\frac{1}{2}; 1\right]$  kesmadagi barcha sonlar bo'ladi.

**Javob:**  $-\frac{1}{2} \leq x \leq 1$ . ▲

Bu funksiyaning grafigidan berilgan tengsizlikdan faqat ishorasi bilan farq qiladigan boshqa tengsizliklarni yechishda ham foydalanish mumkin. 18- rasmdan ko'rib turibdiki:

1)  $2x^2 - x - 1 < 0$  tengsizlikning yechimlari  $-\frac{1}{2} < x < 1$  intervaldagi barcha sonlar;

2)  $2x^2 - x - 1 > 0$  tengsizlikning yechimlari  $x < -\frac{1}{2}$  va  $x > 1$  oraliqlardagi barcha sonlar bo'ladi;

3)  $2x^2 - x - 1 \geq 0$  tengsizlikning yechimlari  $x \leq -\frac{1}{2}$  va  $x \geq 1$  oraliqlardagi barcha sonlar bo'ladi.

**2- masala.** Tengsizlikni yeching:

$$4x^2 + 4x + 1 > 0.$$

△  $y = 4x^2 + 4x + 1$  funksiya grafigining eskizini chizamiz. Bu parabolaning tarmoqlari yuqoriga yo'nalgan.  $4x^2 + 4x + 1 = 0$  tenglama

bitta  $x = -\frac{1}{2}$  ildizga ega, shuning uchun parabola  $Ox$  o'qiga  $\left(-\frac{1}{2}; 0\right)$

nuqtada urinadi. Bu funksiyaning grafigi 19- rasmda tasvirlangan. Berilgan tengsizlikni yechish uchun  $x$  ning qanday qiymatlarda funksiyaning qiymatlari musbat bo'lishini aniqlash kerak. Shunday qilib,  $4x^2 + 4x + 1 > 0$  tengsizlikni  $x$  ning parabolaning nuqtalari  $Ox$  o'qidan yuqorida yotuvchi qiymatlari qanoatlantiradi. 19- rasmdan ko'rib turibdiki, bunday qiymatlar  $x = -0,5$  dan boshqa barcha haqiqiy sonlar bo'ladi.

**Javob:**  $x \neq -0,5$ . ▲

19- rasmdan ko'rib turibdiki:

1)  $4x^2 + 4x + 1 \geq 0$  tengsizlikning yechimi barcha haqiqiy sonlar bo'ladi;

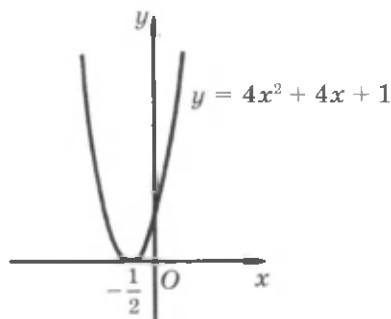

19- rasm.

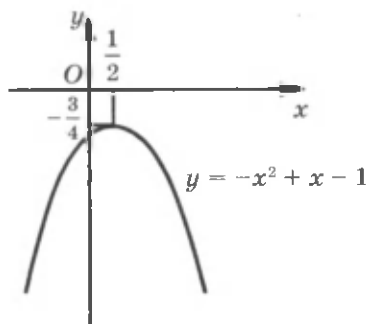

20- rasm.

2)  $4x^2 + 4x + 1 \leq 0$  tengsizlik bitta  $x = -\frac{1}{2}$  yechimga ega;

3)  $4x^2 + 4x + 1 < 0$  tengsizlik yechimlarga ega emas.

Agar  $4x^2 + 4x + 1 = (2x + 1)^2$  ekani e'tiborga olinsa, bu tengsizliklarni og'zaki yechish mumkin.

**3- masala.**  $-x^2 + x - 1 < 0$  tengsizlikni yeching.

$\Delta y = -x^2 + x - 1$  funksiya grafigining eskizini chizamiz. Bu parabolaning tarmoqlari pastga yo'nalgan.  $-x^2 + x - 1 = 0$  tenglamaning haqiqiy ildizlari yo'q, shuning uchun parabola  $Ox$  o'qini kesib o'tmaydi. Demak, bu parabola  $Ox$  o'qidan pastda joylashgan (20- rasm). Bu barcha  $x$  larda kvadrat funksiyaning qiymatlari manfiy, ya'ni  $-x^2 + x - 1 < 0$  tengsizlik  $x$  ning barcha haqiqiy qiymatlarida bajarilishini anglatadi.  $\blacktriangle$

20- rasmdan yana  $-x^2 + x - 1 \leq 0$  tengsizlikning yechimlari  $x$  ning barcha haqiqiy qiymatlari bo'lishi,  $-x^2 + x - 1 > 0$  va  $-x^2 + x - 1 \geq 0$  tengsizliklar esa yechimlarga ega emasligi ko'rinib turibdi.

Shunday qilib, *kvadrat tengsizlikni grafik yordamida yechish uchun:*

1) kvadrat funksiya birinchi koeffitsiyentining ishorasi bo'yicha parabola tarmoqlarining yo'nalishini aniqlash;

2) tegishli kvadrat tenglamaning haqiqiy ildizlarini topish yoki ularning yo'qligini aniqlash;

3) kvadrat funksiyaning  $Ox$  o'qi bilan kesishish nuqtalari yoki urinish nuqtasidan (agar ular bo'lsa) foydalanib, kvadrat funksiya grafigining eskizini yasash;

4) grafik bo'yicha funksiya kerakli qiymatlarni qabul qiladigan oraliqlarni aniqlash kerak.

69.  $y = x^2 + x - 6$  funksiyaning grafigini yasang. Grafik bo'yicha  $x$  ning funksiya musbat qiymatlar; manfiy qiymatlar qabul qiladigan qiymatlarini toping.
70. (Og'zaki.)  $y = ax^2 + bx + c$  funksiya grafigidan foydalanib (21- rasm),  $x$  ning qanday qiymatlarida bu funksiya musbat qiymatlar, manfiy qiymatlar, nolga teng qiymat qabul qilishini ko'rsating.

Kvadrat tengsizlikni yeching (71–75):

- |   |  |
|---|--|
| <p>71. 1) <math>x^2 - 3x + 2 \leq 0</math>;<br/>         3) <math>-x^2 + 3x - 2 &lt; 0</math>;</p> <p>72. 1) <math>2x^2 + 7x - 4 &lt; 0</math>;<br/>         3) <math>-2x^2 + x + 1 \geq 0</math>;</p> <p>73. 1) <math>x^2 - 6x + 9 &gt; 0</math>;<br/>         3) <math>4x^2 - 4x + 1 \geq 0</math>;<br/>         5) <math>-9x^2 - 6x - 1 &lt; 0</math>;</p> <p>74. 1) <math>x^2 - 4x + 6 &gt; 0</math>;<br/>         3) <math>x^2 + x + 2 &gt; 0</math>;<br/>         5) <math>2x^2 - 3x + 7 &lt; 0</math>;</p> | <p>2) <math>x^2 - 3x - 4 \geq 0</math>;<br/>         4) <math>-x^2 + 3x + 4 &gt; 0</math>.</p> <p>2) <math>3x^2 - 5x - 2 &gt; 0</math>;<br/>         4) <math>-4x^2 + 3x + 1 \leq 0</math>.</p> <p>2) <math>x^2 - 14x + 49 \leq 0</math>;<br/>         4) <math>4x^2 - 20x + 25 &lt; 0</math>;<br/>         6) <math>-2x^2 + 6x - 4,5 \leq 0</math>.</p> <p>2) <math>x^2 + 6x + 10 &lt; 0</math>;<br/>         4) <math>x^2 + 3x + 5 &lt; 0</math>;<br/>         6) <math>4x^2 - 8x + 9 &gt; 0</math>.</p> |
|---|--|

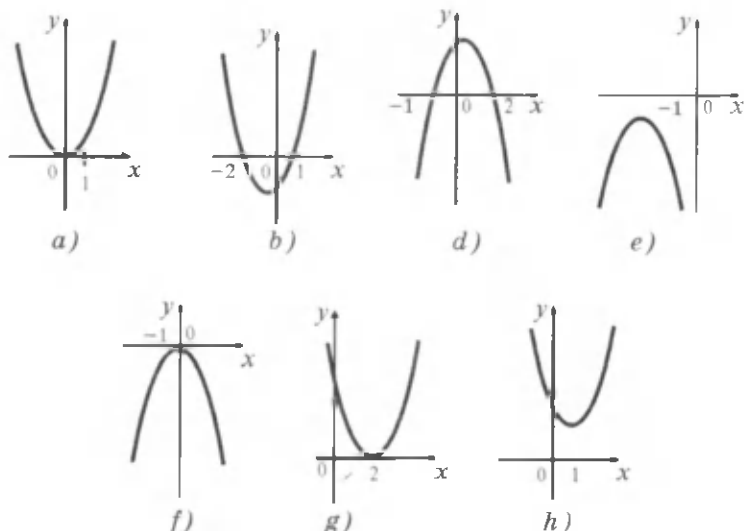

21- rasm.

75. 1)  $5 - x^2 \geq 0$ ; 2)  $-x^2 + 7 < 0$ ;  
 3)  $-2,1x^2 + 10,5x < 0$ ; 4)  $-3,6x^2 - 7,2x < 0$ ;  
 5)  $-6x^2 - x + 12 > 0$ ; 6)  $-3x^2 - 6x + 45 < 0$ ;  
 7)  $-\frac{1}{2}x^2 + 4,5x - 4 > 0$ ; 8)  $-x^2 - 3x - 2 > 0$ .

76. (Og'zaki.) Tengsizlikni yeching:

- 1)  $x^2 + 10 > 0$ ; 2)  $x^2 + 9 < 0$ ;  
 3)  $(x - 1)^2 + 1 > 0$ ; 4)  $(x + 5)^2 + 3 < 0$ ;  
 5)  $-(x + 1)^2 - 2 < 0$ ; 6)  $-(x - 2)^2 - 4 > 0$ ;  
 7)  $0,5x^2 + 8 \leq 0$ ; 8)  $\left(x - \frac{3}{4}\right)^2 + 21 \geq 0$ .

Kvadrat tengsizlikni yeching (77–79):

77. 1)  $4x^2 - 9 > 0$ ; 2)  $9x^2 - 25 > 0$ ;  
 3)  $x^2 - 3x + 2 > 0$ ; 4)  $x^2 - 3x - 4 < 0$ ;  
 5)  $2x^2 - 4x + 9 \leq 0$ ; 6)  $3x^2 + 2x + 4 \geq 0$ ;  
 7)  $\frac{1}{2}x^2 - 4x \geq -8$ ; 8)  $\frac{1}{3}x^2 + 2x \leq -3$ .

78. 1)  $2x^2 - 8x \leq -8$ ; 2)  $x^2 + 12x \geq -36$ ;  
 3)  $9x^2 + 25 < 30x$ ; 4)  $16x^2 + 1 > 8x$ ;  
 5)  $2x^2 - x \geq 0$ ; 6)  $3x^2 + x \leq 0$ ;  
 7)  $0,4x^2 - 1,1x + 1 \geq 0$ ; 8)  $x^2 - x + 0,26 \leq 0$ .

79. 1)  $x(x + 1) < 2(1 - 2x - x^2)$ ; 2)  $x^2 + 2 < 3x - \frac{1}{8}x^2$ ;  
 3)  $6x^2 + 1 \leq 5x - \frac{1}{4}x^2$ ; 4)  $2x(x - 1) < 3(x + 1)$ ;  
 5)  $\frac{5}{3}x - \frac{1}{6}x^2 \leq x + 1$ ; 6)  $\frac{1}{6}x^2 + \frac{2}{3} \geq x - 1$ .

80.  $x$  ning funksiya noldan katta bo'lmagan qiymatlarini qabul qiladigan barcha qiymatlarini toping:

- 1)  $y = -x^2 + 6x - 9$ ; 2)  $y = x^2 - 2x + 1$ ;  
 3)  $y = -\frac{1}{2}x^2 - 3x - 4\frac{1}{2}$ ; 4)  $y = -\frac{1}{3}x^2 - 4x - 12$ .

81. 1)  $x^2 - 2x + q > 0$  tengsizlikning  $q > 1$  bo'lgandagi yechimlari  $x$  ning barcha haqiqiy qiymatlari bo'lishini ko'rsating;  
 2)  $x^2 + 2x + q \leq 0$  tengsizlik  $q > 1$  bo'lganda haqiqiy yechimlarga ega emasligini ko'rsating.

$$x^2 - (2 + r)x + 4 > 0$$

tengsizlik  $x$  ning barcha haqiqiy qiymatlarida bajariladigan barcha qiymatlarini toping.

## 8-§.

## INTERVALLAR USULI

Tengsizliklarni yechishda ko'pincha intervallar usuli qo'llaniladi. Bu usulni misollarda tushuntiramiz.

**1-masala.**  $x$  ning qanday qiymatlarida  $x^2 - 4x + 3$  kvadrat uchhad musbat qiymatlar, qanday qiymatlarida esa manfiy qiymatlar qabul qilishini aniqlang.

$\Delta x^2 - 4x + 3 = 0$  tenglamaning ildizlarini topamiz:

$$x_1 = 1, \quad x_2 = 3.$$

Shuning uchun  $x^2 - 4x + 3 = (x - 1)(x - 3)$ .

$x = 1$  va  $x = 3$  nuqtalar (22- rasm) son o'qini uchta oraliqqa bo'ladi:

$$x < 1, \quad 1 < x < 3, \quad x > 3.$$

$1 < x < 3$  oraliq singari  $x < 1$ ,  $x > 3$  oraliqlar ham *intervallar* deyiladi.

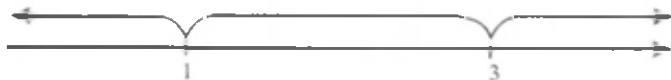

22- rasm.

Son o'qi bo'yicha o'ngdan chapga harakat qilib,  $x > 3$  intervalda  $x^2 - 4x + 3 = (x - 1)(x - 3)$  uchhad musbat qiymatlar qabul qilishini ko'ramiz, chunki bu holda ikkala  $x - 1$  va  $x - 3$  ko'paytuvchi ham musbat.

Keyingi  $1 < x < 3$  intervalda shu uchhad manfiy qiymatlar qabul qiladi va, shunday qilib,  $x = 3$  nuqta orqali o'tishda ishorasini o'zgartiradi. Bu hol shuning uchun ham sodir bo'ladiki,  $(x - 1)(x - 3)$  ko'paytmada  $x = 3$  nuqta orqali o'tishda  $x - 1$  ko'paytuvchi ishorasini o'zgartirmaydi, ikkinchi  $x - 3$  ko'paytuvchi esa ishorasini o'zgartiradi.

$x = 1$  nuqta orqali o'tishda uchhad yana ishorasini o'zgartiradi, chunki  $(x - 1)(x - 3)$  ko'paytmada birinchi  $x - 1$  ko'paytuvchi ishorasini o'zgartiradi, ikkinchi  $x - 3$  ko'paytuvchi esa o'zgartirmaydi.

Demak, son o'qi bo'yicha o'ngdan chapga qarab harakat qilib bir intervaldan qo'shni intervalga o'ta borganda  $(x - 1)(x - 3)$  ko'paytmaning ishoralari almasha boradi.

Shunday qilib,

$$x^2 - 4x + 3$$

kvadrat uchhadning ishorasi haqidagi masalani quyidagi usul bilan yechish mumkin.

$x^2 - 4x + 3 = 0$  tenglamaning ildizlarini son o'qida belgilaymiz:  $x_1 = 1$ ,  $x_2 = 3$ . Ular son o'qini uchta intervalga ajratadi (22- rasm).  $x > 3$  intervalda  $x^2 - 4x + 3$  uchhadning musbat bo'lishini aniqlab, uchhadning qolgan intervallardagi ishoralarini almasha boradigan tartibda belgilaymiz (23- rasm). 23- rasm-dan ko'rinib turibdiki,  $x < 1$  va  $x > 3$  bo'lganda  $x^2 - 4x + 3 > 0$ ,  $1 < x < 3$  bo'lganda esa  $x^2 - 4x + 3 < 0$ . ▲



23- rasm.

Qarab chiqilgan usul *intervallar usuli* deyiladi. Bu usuldan kvadrat tengsizliklarni va ba'zi tengsizliklarni yechishda foydalaniladi.

Masalan, 1- masalani yechganda biz aslida  $x^2 - 4x + 3 > 0$  va  $x^2 - 4x + 3 < 0$  tengsizliklarni intervallar usuli bilan yechdik.

**2- masala.**  $x^3 - x < 0$  tengsizlikni yeching.

△  $x^3 - x$  ko'phadni ko'paytuvchilarga ajratamiz:

$$x^3 - x = x(x^2 - 1) = x(x - 1)(x + 1).$$

Demak, tengsizlikni bunday yozish mumkin:

$$(x + 1)x(x - 1) < 0.$$

Son o'qida  $-1$ ,  $0$  va  $1$  nuqtalarni belgilaymiz. Bu nuqtalar son o'qini to'rtta intervalga ajratadi (24- rasm):

$$x < -1, -1 < x < 0, 0 < x < 1, x > 1.$$

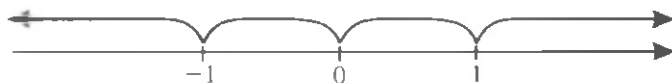

24- rasm.

$x > 1$  bo'lganda  $(x + 1)x(x - 1)$  ko'paytmaning hamma ko'paytuvchilari musbat, shuning uchun  $x > 1$  intervalda  $(x + 1)x(x - 1) > 0$  bo'ladi. Qo'shni intervalga o'tishda ko'paytma ishorasining almashishini e'tiborga olib, har bir interval uchun  $(x + 1)x(x - 1)$  ko'paytmaning ishorasini topamiz (25- rasm).

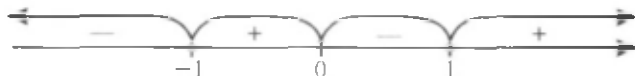

25- rasm.

Shunday qilib, tengsizlikning yechimlari  $x$  ning  $x < -1$  va  $0 < x < 1$  intervallardagi barcha qiymatlari bo'ladi.

**J a v o b:**  $x < -1, 0 < x < 1$ . ▲

**3- m a s a l a.**  $(x^2 - 9)(x + 3)(x - 2) > 0$  tengsizlikni yeching.

△ Berilgan tengsizlikni quyidagi ko'rinishda yozish mumkin:

$$(x + 3)^2(x - 2)(x - 3) > 0. \quad (1)$$

Barcha  $x \neq -3$  da  $(x + 3)^2 > 0$  bo'lgani uchun  $x \neq -3$  da (1) tengsizlikning yechimlari to'plami

$$(x - 2)(x - 3) > 0 \quad (2)$$

tengsizlik yechimlari to'plami bilan ustma-ust tushadi.

$x = -3$  qiymat (1) tengsizlikning yechimi bo'lmaydi, chunki  $x = -3$  bo'lganda tengsizlikning chap qismi 0 ga teng.

(2) tengsizlikni intervallar usuli bilan yechib,  $x < 2$ ,  $x > 3$  ni hosil qilamiz (26- rasm).



26- rasm.

$x = -3$  berilgan tengsizlikning yechimi bo'lmasligini e'tiborga olib, oxirida javobni bunday yozamiz:

$$x < -3, -3 < x < 2, x > 3. \quad \blacktriangle$$

**4- m a s a l a.** Ushbu tengsizlikni yeching:

$$\frac{x^2 + 2x - 3}{x^2 - 3x - 4} \geq 0.$$



△ Kasrning surat va maxrajini ko'paytuvchilarga ajratib quyidagini hosil qilamiz:

$$\frac{(x+3)(x-1)}{(x+1)(x-4)} \geq 0. \quad (3)$$

Son o'qida kasrning surat yoki maxraji nolga aylanadigan  $-3$ ;  $-1$ ;  $1$ ;  $4$  nuqtalarni belgilaymiz. Bu nuqtalar son to'g'ri chizig'ini beshta intervalga ajratadi (27- rasm).  $x > 4$  bo'lganda kasrning surat va maxrajidagi barcha ko'paytuvchilar musbat va shuning uchun kasr musbat.

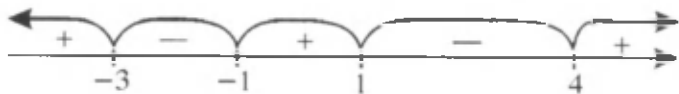

27- rasm.

Bir intervaldan keyingisiga o'tishda kasr ishorasini o'zgartiradi, shuning uchun kasrning ishoralarini 27- rasmdagidek qilib qo'yish mumkin.  $x = -3$  va  $x = 1$  qiymatlar (3) tengsizlikni qanoatlantiradi,  $x = -1$  va  $x = 4$  bo'lganda esa kasr ma'noga ega emas. Shunday qilib, berilgan tengsizlik quyidagi yechimlarga ega:

$$x \leq -3, \quad -1 < x \leq 1, \quad x > 4. \quad \blacktriangle$$

### Mashqlar

83. (Og'zaki.)  $x = 5$  qiymat tengsizlikning yechimi bo'lishini ko'rsating:

$$\begin{array}{ll} 1) (x-1)(x-3) > 0; & 2) (x+2)(x+5) > 0; \\ 3) (x-7)(x-10) > 0; & 4) (x+1)(x-4) > 0. \end{array}$$

Tengsizlikni intervallar usuli bilan yeching (84–90):

$$84. \quad 1) (x+2)(x-7) > 0; \quad 2) (x+5)(x-8) < 0;$$

$$3) (x-2)\left(x+\frac{1}{2}\right) < 0; \quad 4) (x+5)\left(x-3\frac{1}{2}\right) > 0.$$

$$85. \quad 1) x^2 + 5x > 0; \quad 2) x^2 - 9x > 0; \quad 3) 2x^2 - x < 0; \\ 4) x^2 + 3x < 0; \quad 5) x^2 + x - 12 < 0; \quad 6) x^2 - 2x - 3 > 0.$$

$$86. \quad 1) x^3 - 16x < 0; \quad 2) 4x^3 - x > 0; \\ 3) (x^2 - 1)(x + 3) < 0; \quad 4) (x^2 - 4)(x - 5) > 0.$$

87. 1)  $(x - 5)^2(x^2 - 25) > 0$ ;      2)  $(x + 7)^2(x^2 - 49) < 0$ ;  
 3)  $(x - 3)(x^2 - 9) < 0$ ;      4)  $(x - 4)(x^2 - 16) > 0$ ;  
 5)  $(x - 8)(x - 1)(x^2 - 1) \geq 0$ ;      6)  $(x - 5)(x + 2)(x^2 - 4) \leq 0$ .

88. 1)  $\frac{x-2}{x+5} > 0$ ;      2)  $\frac{x-4}{x+3} < 0$ ;      3)  $\frac{1,5-x}{3+x} \geq 0$ ;  
 4)  $\frac{3,5+x}{x-7} \leq 0$ ;      5)  $\frac{(2x+1)(x+2)}{x-3} < 0$ ;      6)  $\frac{(x-3)(2x+4)}{x+1} \geq 0$ .

89. 1)  $\frac{x^2+2x+3}{(x-2)^2} \leq 0$ ;      2)  $\frac{(x+4)^2}{2x^2-3x+1} \geq 0$ ;      3)  $\frac{x^2-x}{x^2-4} > 0$ ;      4)  $\frac{9x^2-4}{x-2x^2} < 0$ .

90. 1)  $(x^2 - 5x + 6)(x^2 - 1) > 0$ ;      2)  $(x + 2)(x^2 + x - 12) > 0$ ;  
 3)  $(x^2 - 7x + 12)(x^2 - x + 2) \leq 0$ ;      4)  $(x^2 - 3x - 4)(x^2 - 2x - 15) \leq 0$ .

Tengsizlikni yeching (91–93):

91. 1)  $\frac{x^2-x-12}{x-1} > 0$ ;      2)  $\frac{x^2-4x-12}{x-2} < 0$ ;

3)  $\frac{x^3+3x-10}{x^2+x-2} \leq 0$ ;      4)  $\frac{x^2-3x-4}{x^2+x-6} \geq 0$ .

92. 1)  $\frac{x}{x-2} + \frac{3}{x} > \frac{3}{x-2}$ ;      2)  $\frac{x^2}{x^2+3x} + \frac{2-x}{x+3} < \frac{5-x}{x}$ .

93. 1)  $\frac{x^2-7x-8}{x^2-64} < 0$ ;      2)  $\frac{x^2+7x+10}{x^2-4} > 0$ ;

3)  $\frac{5x^2-3x-2}{1-x^2} \geq 0$ ;      4)  $\frac{x^2-16}{2x^2+5x-12} > 0$ .

## II bobga doir mashqlar

Tengsizlikni yeching (94–100):

94. 1)  $(x - 5,7)(x - 7,2) > 0$ ;      2)  $(x - 2)(x - 4) > 0$ ;  
 3)  $(x - 2,5)(3 - x) < 0$ ;      4)  $(x - 3)(4 - x) < 0$ .

95. 1)  $x^2 > x$ ;      2)  $x^2 > 36$ ;      3)  $4 > x^2$ ;      4)  $\frac{9}{16} \geq x^2$ .

96. 1)  $-9x^2 + 1 \leq 0$ ; 2)  $-4x^2 + 1 \geq 0$ ;  
 3)  $-5x^2 - x \geq 0$ ; 4)  $-3x^2 + x \leq 0$ .
97. 1)  $-2x^2 + 4x + 30 < 0$ ; 2)  $-2x^2 + 9x - 4 > 0$ ;  
 3)  $4x^2 + 3x - 1 < 0$ ; 4)  $2x^2 + 3x - 2 < 0$ ;  
 5)  $6x^2 + x - 1 > 0$ ; 6)  $5x^2 - 9x + 4 > 0$ .
98. 1)  $x^2 - 2x + 1 \geq 0$ ; 2)  $x^2 + 10x + 25 > 0$ ;  
 3)  $-x^2 + 6x - 9 < 0$ ; 4)  $-4x^2 - 12x - 9 < 0$ ;  
 5)  $\frac{1}{9}x^2 - \frac{4}{3}x + 4 > 0$ ; 6)  $-x^2 + x - \frac{1}{4} < 0$ .
99. 1)  $x^2 - 3x + 8 > 0$ ; 2)  $x^2 - 5x + 10 < 0$ ;  
 3)  $2x^2 - 3x + 5 \geq 0$ ; 4)  $3x^2 - 4x + 5 \leq 0$ ;  
 5)  $-x^2 + 2x + 4 \leq 0$ ; 6)  $-4x^2 + 7x - 5 \geq 0$ .
100. 1)  $(x - 2)(x^2 - 9) > 0$ ; 2)  $(x^2 - 1)(x + 4) < 0$ ;  
 3)  $\frac{(x+3)(x-5)}{x+1} \leq 0$ ; 4)  $\frac{x-7}{(4-x)(2x+1)} \geq 0$ ;  
 5)  $\frac{4x^2-4x-3}{x+3} \geq 0$ ; 6)  $\frac{2x^2-3x-2}{x-1} \geq 0$ .

Tengsizlikni yeching (101–105):

101. 1)  $x^2 > 2 - x$ ; 2)  $x^2 - 3 < 4x$ ; 3)  $x + 8 < 3x^2 - 9$ ;  
 4)  $x^2 \leq 10 - 3x$ ; 5)  $10x - 12 < 2x^2$ ; 6)  $3 - 7x \leq 6x^2$ .
102. 1)  $x^2 + 4 < x$ ; 2)  $x^2 + 3 > 2x$ ; 3)  $-x^2 + 3x \leq 4$ ;  
 4)  $-x^2 - 5x \geq 8$ ; 5)  $3x^2 - 5 > 2x$ ; 6)  $2x^2 + 1 < 3x$ ;  
 7)  $\frac{x^2}{10} + 2 \leq \frac{7x}{10}$ ; 8)  $\frac{x^2}{3} - \frac{2x}{3} > \frac{3x-10}{4}$ .
103. 1)  $\frac{1}{3}x - \frac{4}{9}x^2 \geq 1 - x$ ; 2)  $\frac{1}{3}x(x + 1) \leq (x + 1)^2$ ;  
 3)  $x(1-x) > 1,5-x$ ; 4)  $\frac{1}{3}x - \frac{4}{9} \geq x(x - 1)$ ;  
 5)  $x\left(\frac{x}{4} - 1\right) \leq x^2 + x + 1$ ; 6)  $2x - 2,5 > x(x - 1)$ .
104. 1)  $\frac{2}{x-\sqrt{2}} > \frac{3}{x+\sqrt{2}}$ ; 2)  $\frac{\sqrt{3}}{3-x^2} < \frac{2}{\sqrt{3-x}}$ ;  
 3)  $\frac{9}{2x+2} + \frac{x}{x-1} \geq \frac{1-3x}{2-2x}$ ; 4)  $\frac{3}{x^2-1} - \frac{1}{2} < \frac{3}{2x-2}$ .

## O'ZINGIZNI TEKSHIRIB KO'RING!

1. Tengsizlikni yeching:

1)  $x^2 - 3x - 4 < 0$ ;

2)  $3x^2 - 4x + 8 \geq 0$ ;

3)  $-x^2 + 3x - 5 > 0$ ;

4)  $x^2 + 20x + 100 \leq 0$ .

2. Tengsizlikni intervallar usuli bilan yeching:

$$x(x-1)(x+2) \geq 0.$$

105. 1)  $\frac{3x^2-5x-8}{2x^2-5x-3} > 0$ ;

2)  $\frac{4x^2+x-3}{5x^2+9x-9} < 0$ ;

3)  $\frac{2+7x-4x^2}{3x^2+2x-1} \leq 0$ ;

4)  $\frac{2+9x-5x^2}{3x^2-2x-1} \geq 0$ .

106. Kater 4 soatdan ko'p bo'lmagan vaqt davomida daryo oqimi bo'yicha 22,5 km yurishi va orqasiga qaytishi kerak. Agar daryo oqimining tezligi 3 km/soat bo'lsa, kater suvga nisbatan qanday tezlik bilan yurishi kerak?

107. Funktsiyalarning grafiklarini bitta koordinata sistemasida yasang va  $x$  ning qanday qiymatlarida bir funksiyaning qiymati ikkinchisidan katta (kichik) bo'lishini aniqlang, natijani, tegishli tengsizlikni yechib, tekshiring.

1)  $y = 2x^2$ ,  $y = 2 - 3x$ ;

2)  $y = x^2 - 2$ ,  $y = 1 - 2x$ ;

3)  $y = x^2 - 5x + 4$ ,  $y = 7 - 3x$ ;

4)  $y = 3x^2 - 2x + 5$ ,  $y = 5x + 3$ ;

5)  $y = x^2 - 2x$ ,  $y = -x^2 + x + 5$ ;

6)  $y = 2x^2 - 3x + 5$ ,  $y = x^2 + 4x - 5$ .

108. Tengsizlikni yeching:

1)  $\frac{x^4-5x^2-36}{x^3+x-2} \geq 0$ ;

2)  $\frac{x^4+4x^2-5}{x^2+5x+6} \leq 0$ ;

3)  $\frac{x^4-x^2-2}{x^4+x^2-2} < 0$ ;

4)  $\frac{x^4-2x^2-8}{x^4-2x^2-3} \geq 0$ .

Tengsizlikni yeching (1–12):

1.  $2x^2 - 8 \leq 0$ .

- A)  $-2 \leq x \leq 2$ ;      B)  $-2 \leq x$ ;      C)  $x \geq 2$ ;  
D)  $0 \leq x \leq 4$ ;      E)  $-2 \leq x \leq 4$ .

2.  $-3x^2 + 27 \geq 0$ .

- A)  $x \leq 3$ ;    B)  $|x| \leq 3$ ;    C)  $x \geq 3$ ;    D)  $0 \leq x \leq 9$ ;    E)  $-3 \leq x \leq 0$ .

3.  $3x^2 - 9 \geq 0$ .

- A)  $x < \sqrt{3}$ ;    B)  $x > \sqrt{3}$ ;    C)  $x < -\sqrt{3}, x > \sqrt{3}$ ;    D)  $x \geq 3$ ;    E)  $x < 3$ .

4.  $x^2 + 7x \geq 0$ .

- A)  $x > 0$ ;      B)  $x > 7$ ;      C)  $0 < x < 7$ ;  
D)  $x \leq -7, x \geq 0$ ;      E)  $-7 \leq x \leq 0$ .

5.  $-x^2 + 3x \leq 0$ .

- A)  $x > 3$ ;    B)  $x \geq 0$ ;    C)  $0 < x < 3$ ;    D)  $-3 < x < 3$ ;    E)  $x \leq 0, x \geq 3$ .

6.  $(x + 3)(x - 4) > 0$ .

- A)  $x < -3, x > 4$ ;      B)  $-3 < x < 4$ ;  
C)  $x > 4$ ;      D)  $x < -3$ ;      E)  $0 < x < 4$ .

7.  $(x - 1)(x + 7) < 0$ .

- A)  $x > -7$ ;      B)  $-7 < x < 1$ ;    C)  $x > 1$ ;  
D)  $x < -7, x > 1$ ;    E)  $-1 < x < 7$ .

8.  $6x^2 + 5x - 6 > 0$ .

- A)  $x > \frac{2}{3}$ ;    B)  $x < \frac{3}{2}$ ;    C)  $x < -\frac{3}{2}, x > \frac{2}{3}$ ;    D)  $-\frac{3}{2} < x < \frac{2}{3}$ ;  
E) yechimi yoq.

9.  $-4x^2 + 8x - 3 > 0$ .

- A)  $x > \frac{3}{2}$ ;    B)  $x < \frac{1}{2}$ ;    C)  $x < -\frac{1}{2}$ ;    D)  $\frac{1}{2} < x < \frac{3}{2}$ ;    E)  $-\frac{3}{2} < x < \frac{1}{2}$ .

10.  $\frac{x^2 - 7x + 10}{x^2 - 3x - 10} \leq 0$ .

- A)  $2 < x < 5$ ;      B)  $-2 < x < 5$ ;    C)  $x \neq -2, x \neq 5$ ;  
D)  $-2 < x < 0$ ;      E)  $-2 < x \leq 2$ .

11.  $\frac{x^2+x}{-x^2+6x-8} \geq 0$ .  
 A)  $-1 \leq x \leq 0, 2 < x < 4$ ; B)  $-2 < x < 4$ ; C)  $0 \leq x \leq 1$ ;  
 D)  $-1 \leq x < 4$ ; E) to'g'ri javob berilmagan.
12.  $\frac{x^2-1}{x^2-x-6} \geq 0$ .  
 A)  $-2 < x < 3$ ; B)  $x < -2; -1 \leq x \leq 1, x > 3$ ; C)  $-1 \leq x < 3$ ;  
 D)  $x \neq -2, x \neq 3$ ; E)  $-1 \leq x < 6$ .
13.  $x^2 + 6x + 5 < 0$  tengsizlikning barcha butun yechimlari yig'indisini toping.  
 A) 10; B) 9; C) -9; D) -10; E) -15.
14.  $\frac{x^2-6x-7}{x^2+4x+4} \leq 0$  tengsizlikning barcha natural yechimlari yig'indisini toping.  
 A) 29; B) 24; C) 25; D) 28; E) 27.
15.  $p$  ning nechta butun qiymatida  $x^2 + px + 9 = 0$  tenglama haqiqiy ildizga ega emas?  
 A) 10; B) 8; C) 13; D) 12; E) 11.
16.  $a$  ning qanday qiymatlarida  $ax^2 + 4x + 9a < 0$  tengsizlik  $x$  ning barcha qiymatlarida o'rinli bo'ladi?  
 A)  $a < -\frac{2}{3}$ ; B)  $a > \frac{2}{3}$ ; C)  $a < -1$ ; D)  $a > 1$ ; E)  $-\frac{2}{3} < a < \frac{3}{2}$ .
17.  $k$  ning qanday eng kichik butun qiymatida  $x^2 - 2(k+3)x + 20 + k^2 = 0$  tenglama ikkita turli haqiqiy ildizlarga ega bo'ladi?  
 A)  $k = 3$ ; B)  $k = 2$ ; C)  $k = 1$ ; D)  $k = -2$ ; E)  $k = -1$ .
18.  $k$  ning qanday qiymatlarida  $\frac{4x-3}{x+2} = k+1$  tenglama manfiy ildizga ega?  
 A)  $\frac{3}{4} < k < 2$ ; B)  $\frac{5}{2} < k < 3$ ; C)  $k < -\frac{5}{2}, k > 3$ ; D)  $k > 3$ ;  
 E)  $-\frac{5}{2} < k < 3$ .
19.  $a$  ning qanday qiymatida  $ax^2 - 8x - 2 < 0$  tengsizlik  $x$  ning barcha qiymatlarida o'rinli bo'ladi?  
 A)  $-8 < a < 8$ ; B)  $a \geq 8$ ; C)  $a < 8$ ; D)  $a < -8$ ; E)  $a > -8$ .

20.  $a$  ning qanday qiymatlarida  $4(x + 2) = 5 - ax$  tenglamaning ildizi  $-2$  dan katta bo'ladi?
- A)  $a \geq -4$ ; B)  $-\frac{5}{2} < a < 4$ ; C)  $-4 < a < \frac{5}{2}$ ; D)  $a \geq \frac{5}{2}, a < -4$ ;  
E)  $a < -4, a > -\frac{5}{2}$ .
21. Tengsizlikni yeching:  $\frac{1}{x} \geq x$ .
- A)  $x \leq -1, 0 < x \leq 1$ ; B)  $x \leq -1$ ; C)  $0 < x < 1$ ; D)  $-1 \leq x \leq 1$ ;  
E) to'g'ri javob berilmagan.
22. Tengsizlikni yeching:  $\frac{2x-1}{x} < 2$ .
- A)  $x < 0$ ; B)  $x > 0$ ; C)  $\frac{1}{2} < x < 2$ ; D)  $x < 2$ ; E)  $x > \frac{1}{2}$ .
23.  $\frac{x-3}{x+2} \leq 0$  tengsizlikning barcha butun yechimlari yig'indisini toping.
- A)  $-3$ ; B)  $6$ ; C)  $3$ ; D)  $4$ ; E)  $-5$ .
24.  $\frac{x^2-x+20}{x^2+11x+24} \geq 0$  tengsizlikni yeching.
- A)  $x < -8, x \geq 5$ ; B)  $-4 \leq x < -3$ ; C)  $-4 \leq x \leq 5$ ;  
D)  $x < -8, -4 \leq x < 3, x \geq 5$ ; E)  $x < -3, x > 5$ .
25.  $\frac{-x^2-5x+6}{x^2+7x+10} \geq 0$  tengsizlikning barcha butun yechimlari ko'paytmasini toping.
- A)  $1$ ; B)  $-1$ ; C)  $-6$ ; D)  $2$ ; E)  $0$ .

# III BOB. RATSIONAL KO'RSATKICHLI DARAJA

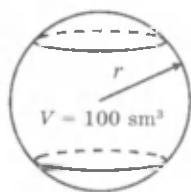

$$a < r ?$$
$$a > r ?$$

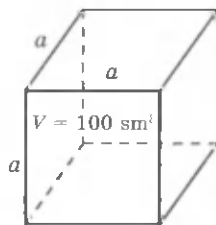

## 9- §.

## BUTUN KO'RSATKICHLI DARAJA

Natural ko'rsatkichli darajaning xossalari qaralganda darajalarni bo'lishning

$$a^n : a^m = a^{n-m} \quad (1)$$

xossasi  $n > m$  va  $a \neq 0$  bo'lganda to'g'riligi ta'kidlangan edi.

Agar  $n \leq m$  bo'lsa, u holda (1) tenglikning o'ng qismidagi  $n - m$  daraja ko'rsatkich manfiy son yoki nolga teng bo'ladi.

*Manfiy va nol ko'rsatkichli daraja* shunday aniqlanadiki, (1) tenglik faqat  $n > m$  bo'lgandagina emas, balki  $n \leq m$  bo'lganda ham to'g'ri bo'ladi. Masalan,  $n = 2$ ,  $m = 5$  bo'lganda (1) formula bo'yicha quyidagini hosil qilamiz:

$$a^2 : a^5 = a^{2-5} = a^{-3}.$$

Ikkinchi tomondan,

$$a^2 : a^5 = \frac{a^2}{a^5} = \frac{a^2}{a^2 a^3} = \frac{1}{a^3}.$$

Shuning uchun  $a^{-3} = \frac{1}{a^3}$  deb hisoblanadi.

**1-ta'rif.** Agar  $a \neq 0$  va  $n$  - natural son bo'lsa, u holda

$$a^{-n} = \frac{1}{a^n}$$

bo'ladi.



**Misollar:**

$$1) 2^{-3} = \frac{1}{2^3} = \frac{1}{8}; \quad 2) (-3)^{-4} = \frac{1}{(-3)^4} = \frac{1}{81};$$

$$3) (-0,5)^{-3} = \frac{1}{(-0,5)^3} = -\frac{1}{0,125} = -8.$$

Agar  $n = m$  bo'lsa, u holda (1) formula bo'yicha quyidagini hosil qilamiz:

$$a^n : a^n = a^{n-n} = a^0.$$

Ikkinchi tomondan,  $a^n : a^n = \frac{a^n}{a^n} = 1$ . Shuning uchun  $a^0 = 1$  deb hisoblanadi.



**2-ta'rif.** Agar  $a \neq 0$  bo'lsa, u holda  $a^0 = 1$  bo'ladi.

Masalan,  $3^0 = 1$ ,  $\left(\frac{2}{5}\right)^0 = 1$ .

Manfiy ko'rsatkichli darajalardan sonni *standart shaklda yozishda* foydalanilgan. Masalan,

$$0,00027 = 2,7 \cdot \frac{1}{10^4} = 2,7 \cdot 10^{-4}.$$

*Natural ko'rsatkichli darajalarning barcha xossalari istalgan butun ko'rsatkichli darajalar uchun ham to'g'ri bo'ladi.*

**Istalgan  $a \neq 0$ ,  $b \neq 0$  va istalgan butun  $n$  va  $m$  lar uchun quyidagi tengliklar to'g'ri:**

1.  $a^n a^m = a^{n+m}$ .

4.  $a^n : a^m = a^{n-m}$ .

2.  $(a^n)^m = a^{nm}$ .

5.  $(ab)^n = a^n b^n$ .

3.  $\left(\frac{a}{b}\right)^n = \frac{a^n}{b^n}$ .



Masalan,  $n < 0$  bo'lganda  $(ab)^n = a^n b^n$  tenglikning to'g'riligini isbot qilamiz.

○  $n$  - butun manfiy son bo'lsin. U holda  $n = -k$  (bunda  $k$  - natural son). Manfiy ko'rsatkichli darajaning ta'rifidan va natural ko'rsatkichli darajaning xossalardan foydalanib, quyidagini hosil qilamiz:

$$(ab)^n = (ab)^{-k} = \frac{1}{(ab)^k} = \frac{1}{a^k b^k} = \frac{1}{a^k} \cdot \frac{1}{b^k} = \\ = a^{-k} \cdot b^{-k} = a^n b^n. \bullet$$

Butun ko'rsatkichli darajalarning boshqa xossalari ham shunga o'xshash isbot qilinadi.

Butun ko'rsatkichli darajalarning xossalari qo'llashga misollar keltiramiz:

$$1) 4^{-3} \cdot 4^{11} \cdot 4^{-6} = 4^{-3+11-6} = 4^2 = 16;$$

$$2) \left( \frac{p^{-3}}{3q^2} \right)^{-2} = \frac{p^{-3 \cdot (-2)}}{3^{-2} \cdot q^{2 \cdot (-2)}} = \frac{3^2 p^6}{q^{-4}} = 9p^6 q^4.$$

**Masala.**  $a^6(a^{-2} - a^{-4})(a^2 + a^3)^{-1}$  ifodani soddalashtiring:

$$\Delta a^6(a^{-2} - a^{-4})(a^2 + a^3)^{-1} = a^6 \left( \frac{1}{a^2} - \frac{1}{a^4} \right) \cdot \frac{1}{a^2 + a^3} = \\ = a^6 \cdot \frac{a^2 - 1}{a^4} \cdot \frac{1}{a^2(1+a)} = a - 1. \blacktriangle$$

### Mashqlar

109. Hisoblang:

$$1) 2^3 + (-3)^3 - (-2)^2 + (-1)^5; \quad 2) (-7)^2 - (-4)^3 - 3^4; \\ 3) 13 \cdot 2^3 - 9 \cdot 2^3 + 2^3; \quad 4) 6(-2)^3 - 5(-2)^3 - (-2)^3.$$

110. Ifodani natural ko'rsatkichli daraja shaklida tasvirlang:

$$1) \frac{7^2 \cdot 7^{15}}{7^{13}}; \quad 2) \frac{5^3 \cdot 5^{10} \cdot 5}{5^4 \cdot 5^{15}}; \quad 3) \frac{a^2 a^8 b^3}{a^9 b^2}; \quad 4) \frac{c^3 d^5 c^9}{c^{10} d^7}.$$

111. (Og'zaki.) Hisoblang:

$$1) 1^{-5}; \quad 2) 4^{-3}; \quad 3) (-10)^0; \quad 4) (-5)^{-2}; \quad 5) \left( \frac{1}{2} \right)^{-4}; \quad 6) \left( \frac{3}{4} \right)^{-1}.$$

112. Manfiy ko'rsatkichli daraja shaklida yozing:

$$1) \frac{1}{4^5}; \quad 2) \frac{1}{21^3}; \quad 3) \frac{1}{x^7}; \quad 4) \frac{1}{a^9}.$$

Hisoblang (113–114):

113. 1)  $\left(\frac{10}{3}\right)^{-3}$ ;      2)  $\left(-\frac{9}{11}\right)^{-2}$ ;      3)  $(0,2)^{-4}$ ;  
4)  $(0,5)^{-5}$ ;      5)  $-(-17)^{-1}$ ;      6)  $-(-13)^{-2}$ .

114. 1)  $3^{-1} + (-2)^{-2}$ ;      2)  $\left(\frac{2}{3}\right)^{-3} - 4^{-2}$ ;  
3)  $(0,2)^{-2} + (0,5)^{-5}$ ;      4)  $(-0,1)^{-3} - (-0,2)^{-3}$ .

115. (Og‘zaki.) Bir bilan taqqoslang:

1)  $12^{-3}$ ;      2)  $21^0$ ;      3)  $(0,6)^{-5}$ ;      4)  $\left(\frac{5}{19}\right)^{-4}$ .

116. Ifodani manfiy ko‘rsatkichsiz daraja shaklida yozing:

1)  $(x - y)^{-2}$ ;      2)  $(x + y)^{-3}$ ;      3)  $3^{-5}c^8$ ;  
4)  $9a^3b^{-4}$ ;      5)  $a^{-1}b^2c^{-3}$ ;      6)  $a^2b^{-1}c^{-4}$ .

Hisoblang (117–118):

117. 1)  $\left(\frac{1}{7}\right)^{-3} \cdot \left(\frac{1}{7}\right)$ ;      2)  $\left(-\frac{1}{5}\right) \cdot \left(-\frac{1}{5}\right)^{-4}$ ;      3)  $0,3^7 \cdot 0,3^{-10}$ ;      4)  $17^{-5} \cdot 17^3 \cdot 17$ .

118. 1)  $9^7 : 9^{10}$ ;      2)  $(0,2)^2 : (0,2)^{-2}$ ;      3)  $\left(\frac{2}{13}\right)^{12} : \left(\frac{2}{13}\right)^{-10}$ ;      4)  $\left(\frac{2}{5}\right)^3 : \left(\frac{2}{5}\right)^{-1}$ .

119. Darajani darajaga ko‘taring:

1)  $(a^3)^{-5}$ ;      2)  $(b^{-2})^{-4}$ ;      3)  $(a^{-3})^7$ ;      4)  $(b^7)^{-4}$ .

120. Ko‘paytmani darajaga ko‘taring:

1)  $(ab^{-2})^3$ ;      2)  $(a^2b^{-1})^4$ ;      3)  $(2a^2)^{-6}$ ;      4)  $(3a^3)^{-4}$ .

121. Amallarni bajaring:

1)  $\left(\frac{a^8}{b^7}\right)^{-2}$ ;      2)  $\left(\frac{m^{-4}}{n^{-5}}\right)^{-3}$ ;      3)  $\left(\frac{2x^6}{3y^{-4}}\right)^2$ ;      4)  $\left(\frac{-4x^{-5}y}{z^3}\right)^3$ .

122. 1)  $x = 5, y = 6, 7$  bo‘lganda,  $(x^2y^{-2} - 4y^{-2}) \cdot \left(\frac{1}{y}\right)^{-2}$  ning qiymatini hisoblang; 2)  $a = 2, b = -3$  bo‘lganda  $((a^2b^{-1})^4 - a^0b^4) : \frac{a^4 - b^4}{b^2}$  ning qiymatini hisoblang.

Standart shaklda yozing (123–124):

123. 1)  $200\,000^4$ ;      2)  $0,003^3$ ;      3)  $4000^{-2}$ ;      4)  $0,002^{-3}$ .

124. 1)  $0,0000087$ ;      2)  $0,00000005086$ ;      3)  $\frac{1}{125}$ ;      4)  $\frac{1}{625}$ .

125. Oynani silliqlash jarayoni uning sirtidagi o'yiqliklar chuqurligi  $3 \cdot 10^{-3}$  mm dan ortmaydigan bo'lganda to'xtatiladi. Shu sonni o'nli kasr shaklida yozing.

126. O'rta og'irlikdagi vodorod 0,00 000 000 001 sekundgina «yashaydi» (mavjud bo'ladi). Shu sonni manfiy ko'rsatkichli daraja shaklida yozing.

---

127. Gripp virusining o'lchamlari taqriban  $10^{-4}$  mm ni tashkil qiladi. Shu sonni o'nli kasr shaklida yozing.

128. Kasrni daraja shaklida tasvirlang va uning qiymatini  $a$  ning berilgan qiymatida toping:

1)  $\frac{a^8 a^{-7}}{a^{-2}}$ ,  $a = 0,8$ ;      2)  $\frac{a^{15} a^3}{a^{13}}$ ,  $a = \frac{1}{2}$ .

129. Hisoblang:

1)  $((-20)^7)^{-7} : ((-20)^{-6})^8 + 2^{-2}$ ;      2)  $((-17)^{-4})^{-6} : ((-17)^{-13})^{-2} - \left(\frac{1}{17}\right)^2$ .

**130.** Soddalashtiring:

1)  $(a^{-3} + b^{-3}) \cdot (a^{-2} - b^{-2})^{-1} \cdot (a^{-2} - a^{-1}b^{-1} + b^{-2})^{-1}$ ;  
2)  $(a^{-2}b - ab^{-2}) \cdot (a^{-2} + a^{-1}b^{-1} + b^{-2})^{-1}$ .

---

## 10-§. NATURAL KO'RSATKICHLI DARAJANING ARIFMETIK ILDIZI

O'rta Osiyolik atoqli matematik va astronom **Jamshid ibn Ma'sud ibn Mahmud G'iyosiddin al-Koshiy** (taxminan 1430- yilda vafot etgan) sonlardan istalgan  $n$ - darajali ildiz chiqarish amalini kashf qildi. Uning «Hisob kaliti» nomli asarining beshinchi bobi «darajaning asosini aniqlash» deb nomlangan.

Quyidagi masalani qaraylik.

**1 - masala.** Tenglamani yeching:  $x^4 = 81$ .

$\Delta$  Tenglamani  $x^4 - 81 = 0$  yoki  $(x^2 - 9)(x^2 + 9) = 0$  ko'rinishida yozib olamiz.  $x^2 + 9 \neq 0$  bo'lgani uchun  $x^2 - 9 = 0$  bo'ladi, bundan,  $x_1 = 3$ ,  $x_2 = -3$ .  $\blacktriangle$

Shunday qilib,  $x^4 = 81$  tenglama ikkita haqiqiy ildizga ega:  $x_1 = 3$ ,  $x_2 = -3$ . Ularni 81 sonining 4- darajali ildizlari, musbat ildizni (3 sonini) esa 81 sonining 4- darajali arifmetik ildizi deyiladi va bunday belgilanadi:  $\sqrt[4]{81}$ . Shunday qilib,  $\sqrt[4]{81} = 3$ .

$x^n = a$  tenglama (bunda  $n$  — natural son,  $a$  — nomanfiy son) yagona nomanfiy ildizga ega ekanligini isbotlash mumkin. Bu ildizni  $a$  sonning  $n$ - darajali arifmetik ildizi deyiladi.

**Ta'rif.**  $a$  nomanfiy sonning  $n \geq 2$  natural ko'rsatkichli arifmetik ildizi deb,  $n$ - darajasi  $a$  ga teng bo'lgan nomanfiy sonni aytiladi.

  $a$  sonning  $n$ - darajali arifmetik ildizi bunday belgilanadi:  $\sqrt[n]{a}$ .  $a$  son ildiz ostidagi ifoda deyiladi. Agar  $n = 2$  bo'lsa, u holda  $\sqrt[n]{a}$  o'rniga  $\sqrt{a}$  yoziladi.

Ikkinchi darajali arifmetik ildiz *kvadrat ildiz* ham deyiladi, 3- darajali ildiz esa *kub ildiz* deyiladi.

So'z  $n$ - darajali arifmetik ildiz haqida yuritilayotgani aniq bo'lgan hollarda qisqacha « $n$ - darajali ildiz» deyiladi.

Ta'rifdan foydalanib,  $\sqrt[n]{a}$  ning  $b$  ga tengligini isbotlash uchun:

1)  $b \geq 0$ ; 2)  $b^n = a$  ekanligini ko'rsatish kerak.

Masalan,  $\sqrt[3]{64} = 4$ , chunki  $4 > 0$  va  $4^3 = 64$ .

Arifmetik ildizning ta'rifidan, agar  $a \geq 0$  bo'lsa, u holda

$$(\sqrt[n]{a})^n = a, \quad \sqrt[n]{a^n} = a$$

bo'lishi kelib chiqadi.

Masalan,  $(\sqrt[5]{7})^5 = 7$ ,  $\sqrt[6]{13^6} = 13$ .

$n$ - darajali ildiz izlanayotgan amal  $n$ - darajali ildiz chiqarish amali deyiladi. U  $n$ - darajaga ko'tarish amaliga teskari amaldir.

2- masala.  $x^3 = -8$  tenglamani yeching.

$\triangle$  Bu tenglamani  $-x^3 = 8$  yoki  $(-x)^3 = 8$  kabi yozish mumkin.  $-x = y$  deb belgilaymiz, u holda  $y^3 = 8$  bo'ladi.

Bu tenglama bitta ildizga ega:  $y = \sqrt[3]{8} = 2$ .  $y^3 = 8$  tenglama manfiy ildizga ega emas, chunki  $y < 0$  bo'lganda  $y^3 < 0$  bo'ladi.  $y = 0$  soni ham bu tenglamaning ildizi bo'la olmaydi.

Shunday qilib,  $y^3 = 8$  tenglama faqat bitta  $y = 2$  ildizga ega, demak,  $x^3 = -8$  tenglama ham faqat bitta ildizga ega:  $x = -y = -2$ .

**Javob.**  $x = -2$ .  $\blacktriangle$

$x^3 = -8$  tenglamaning yechimini qisqacha bunday yozish mumkin:

$$x = -\sqrt[3]{8} = -2.$$

 **Umuman, istalgan toq  $2k + 1$  natural son uchun  $a < 0$  bo'lganda  $x^{2k+1} = a$  tenglama faqat bitta, buning ustiga manfiy ildizga ega. Bu ildiz xuddi arifmetik ildiz kabi bunday belgilanadi:  $\sqrt[2k+1]{a}$ . Uni manfiy sonning toq darajali ildizi deyiladi.**

Masalan,  $\sqrt[3]{-27} = -3$ ,  $\sqrt[5]{-32} = -2$ .

$a$  sonning toq darajali ildizi bilan  $-a = |a|$  sonning arifmetik ildizi orasida ushbu tenglik mavjud:

$${}^{2k+1}\sqrt{a} = -{}^{2k+1}\sqrt{-a} = {}^{2k+1}\sqrt{|a|}.$$

Masalan,  $\sqrt[5]{-243} = -\sqrt[5]{243} = -3$ .

### Mashqlar

131. (Og'zaki.) 1) Sonning arifmetik kvadrat ildizini toping:

$$1; 0; 16; 0,81; 169; \frac{1}{289}.$$

2) Sonning arifmetik kub ildizini toping:

$$1; 0; 125; \frac{1}{27}; 0,027; 0,064.$$

3) Sonning to'rtinchi darajali arifmetik ildizini toping:

$$0; 1; 16; \frac{16}{81}; \frac{256}{625}; 0,0016.$$

Hisoblang (132–134):

132. 1)  $\sqrt[6]{36^3}$ ; 2)  $\sqrt[12]{64^2}$ ; 3)  $\sqrt[4]{\left(\frac{1}{25}\right)^2}$ ; 4)  $\sqrt[8]{225^4}$ .

133. 1)  $\sqrt[3]{10^6}$ ; 2)  $\sqrt[3]{3^{12}}$ ; 3)  $\sqrt[4]{\left(\frac{1}{2}\right)^{12}}$ ; 4)  $\sqrt[4]{\left(\frac{1}{3}\right)^{16}}$ .

134. 1)  $\sqrt[3]{-8}$ ; 2)  $\sqrt[4]{-1}$ ; 3)  $\sqrt[3]{-\frac{1}{27}}$ ; 4)  $\sqrt[5]{-1024}$ ; 5)  $\sqrt[3]{-34^3}$ ; 6)  $\sqrt[7]{-8^7}$ .

135. Tenglamani yeching:

1)  $x^4 = 81$ ; 2)  $x^5 = -\frac{1}{32}$ ; 3)  $5x^5 = -160$ ; 4)  $2x^6 = 128$ .

136.  $x$  ning qanday qiymatlarida ifoda ma'noga ega bo'ladi:

1)  $\sqrt[6]{2x-3}$ ; 2)  $\sqrt[3]{x+3}$ ; 3)  $\sqrt[3]{2x^2-x-1}$ ; 4)  $\sqrt[4]{\frac{2-3x}{2x-4}}$ ?

Hisoblang (137–138):

137. 1)  $\sqrt[3]{-125} + \frac{1}{8}\sqrt[6]{64}$ ; 2)  $\sqrt[5]{32} - 0,5\sqrt[3]{-216}$ ;  
3)  $-\frac{1}{3}\sqrt[4]{81} + \sqrt[4]{625}$ ; 4)  $\sqrt[3]{-1000} - \frac{1}{4}\sqrt[4]{256}$ ;  
5)  $\sqrt[4]{0,0001} - 2\sqrt{0,25} + \sqrt[5]{\frac{1}{32}}$ ; 6)  $\sqrt[5]{\frac{1}{243}} + \sqrt[3]{-0,001} - \sqrt[4]{0,0016}$ .

138. 1)  $\sqrt{9+\sqrt{17}} \cdot \sqrt{9-\sqrt{17}}$ ; 2)  $(\sqrt{3+\sqrt{5}} - \sqrt{3-\sqrt{5}})^2$ ;  
3)  $(\sqrt{5+\sqrt{21}} + \sqrt{5-\sqrt{21}})^2$ ; 4)  $\frac{\sqrt{3+\sqrt{2}}}{\sqrt{3-\sqrt{2}}} - \frac{\sqrt{3-\sqrt{2}}}{\sqrt{3+\sqrt{2}}}$ .

139. 1) a)  $x \geq 2$ ; b)  $x < 2$  bo'lganda  $\sqrt[3]{(x-2)^3}$  ni soddalashtiring;  
2) a)  $x \leq 3$ ; b)  $x > 3$  bo'lganda  $\sqrt{(3-x)^6}$  ni soddalashtiring.

140.  $1987 < \sqrt{n} < 1998$  bo'ladigan nechta natural son  $n$  bor?

$n$ - darajali arifmetik ildiz quyidagi kossalarga ega:

Agar  $a \geq 0$ ,  $b > 0$ ,  $n, m$  natural sonlar bo'lib,  $n \geq 2$ ,  $m \geq 2$  bo'lsa, u holda quyidagi tengliklar to'g'ri bo'ladi:



$$1. \sqrt[n]{ab} = \sqrt[n]{a}\sqrt[n]{b}. \quad 3. (\sqrt[n]{a})^m = \sqrt[n]{a^m}.$$

$$2. \sqrt[n]{\frac{a}{b}} = \frac{\sqrt[n]{a}}{\sqrt[n]{b}}. \quad 4. \sqrt[m]{\sqrt[n]{a}} = \sqrt[nm]{a}.$$

1- kossada  $b$  son 0 ga teng bo'lishi ham mumkin. 3- kossada  $m$  son, agar  $a > 0$  bo'lsa, istalgan butun son bo'lishi mumkin.

Masalan,

$$\sqrt[n]{ab} = \sqrt[n]{a}\sqrt[n]{b}.$$

ekanligini isbot qilamiz.

○ Arifmetik ildizning ta'rifidan foydalanamiz:

$$1) \sqrt[n]{a}\sqrt[n]{b} \geq 0, \text{ chunki } a \geq 0 \text{ va } b \geq 0.$$

$$2) (\sqrt[n]{a}\sqrt[n]{b})^n = ab, \text{ chunki } (\sqrt[n]{a}\sqrt[n]{b})^n = (\sqrt[n]{a})^n (\sqrt[n]{b})^n = ab. \bullet$$

Qolgan kossalar ham shunga o'xshash isbot qilinadi.

Arifmetik ildizning kossalarini qo'llashga misollar keltiramiz.

$$1) \sqrt[4]{27} \cdot \sqrt[4]{3} = \sqrt[4]{27 \cdot 3} = \sqrt[4]{81} = \sqrt[4]{3^4} = 3.$$

$$2) \sqrt[3]{\frac{256}{625}} : \sqrt[3]{\frac{4}{5}} = \sqrt[3]{\frac{256}{625} : \frac{4}{5}} = \sqrt[3]{\frac{64}{125}} = \frac{4}{5}; \quad 3) \sqrt[7]{5^{21}} = (\sqrt[7]{5^7})^3 = 5^3 = 125;$$

$$4) \sqrt[3]{\sqrt[4]{4096}} = \sqrt[12]{4096} = \sqrt[12]{2^{12}} = 2; \quad 5) (\sqrt[4]{9})^{-2} = \sqrt[4]{9^{-2}} = \sqrt[4]{\frac{1}{81}} = \frac{1}{3}.$$

**Masala.** Ifodani soddalashtiring:

$$\frac{(\sqrt[4]{a^3 b^2})^4}{\sqrt[3]{\sqrt{a^{12} b^6}}}$$

bunda  $a > 0$ ,  $b > 0$ .



△ Arifmetik ildizning xossalariidan foydalanib, hosil qilamiz:

$$\frac{(\sqrt[4]{a^3b^2})^4}{\sqrt[3]{\sqrt{a^{12}b^6}}} = \frac{a^3b^2}{\sqrt[6]{a^{12}b^6}} = \frac{a^3b^2}{a^2b} = ab. \blacktriangle$$

### Mashqlar<sup>1</sup>

Hisoblang (141–144):

141. 1)  $\sqrt[3]{343 \cdot 0,125}$ ;                      2)  $\sqrt[3]{864 \cdot 216}$ ;  
 3)  $\sqrt[4]{256 \cdot 0,0081}$ ;                      4)  $\sqrt[5]{32 \cdot 100000}$ .
142. 1)  $\sqrt[3]{5^3 \cdot 7^3}$ ;                      2)  $\sqrt[4]{11^4 \cdot 3^4}$ ;                      3)  $\sqrt[5]{(0,2)^5 \cdot 8^5}$ ;                      4)  $\sqrt[7]{\left(\frac{1}{3}\right)^7 \cdot 21^7}$ .
143. 1)  $\sqrt[3]{2} \cdot \sqrt[3]{500}$ ;                      2)  $\sqrt[3]{0,2} \cdot \sqrt[3]{0,04}$ ;                      3)  $\sqrt[4]{324} \cdot \sqrt[4]{4}$ ;                      4)  $\sqrt[5]{2} \cdot \sqrt[5]{16}$ .
144. 1)  $\sqrt[5]{3^{10} \cdot 2^{15}}$ ;                      2)  $\sqrt[3]{2^3 \cdot 5^6}$ ;                      3)  $\sqrt[4]{3^{12} \cdot \left(\frac{1}{3}\right)^8}$ ;                      4)  $\sqrt[10]{4^{30} \cdot \left(\frac{1}{2}\right)^{20}}$ .

145. Ildiz chiqaring:

- 1)  $\sqrt[3]{64x^3z^6}$ ;                      2)  $\sqrt[4]{a^8b^{12}}$ ;                      3)  $\sqrt[5]{32x^{10}y^{20}}$ ;                      4)  $\sqrt[6]{a^{12}b^{18}}$ .

146. Ifodani soddalashtiring:

- 1)  $\sqrt[3]{2ab^2} \cdot \sqrt[3]{4a^2b}$ ;                      2)  $\sqrt[4]{3a^2b^3} \cdot \sqrt[4]{27a^2b}$ ;  
 3)  $\sqrt[4]{\frac{ab}{c}} \cdot \sqrt[4]{\frac{a^3c}{b}}$ ;                      4)  $\sqrt[3]{\frac{16a}{b^2}} \cdot \sqrt[3]{\frac{1}{2ab}}$ .

Hisoblang (147–148):

147. 1)  $\sqrt[3]{\frac{64}{125}}$ ;                      2)  $\sqrt[4]{\frac{16}{81}}$ ;                      3)  $\sqrt[3]{3\frac{3}{8}}$ ;                      4)  $\sqrt[5]{7\frac{19}{32}}$ .
148. 1)  $\sqrt[4]{324} : \sqrt[4]{4}$ ;                      2)  $\sqrt[3]{128} : \sqrt[3]{2000}$ ;                      3)  $\frac{\sqrt[3]{16}}{\sqrt[3]{2}}$ ;  
 4)  $\frac{\sqrt[5]{256}}{\sqrt[5]{8}}$ ;                      5)  $(\sqrt{20} - \sqrt{45}) : \sqrt{5}$ ;                      6)  $(\sqrt[3]{625} - \sqrt[3]{5}) : \sqrt[3]{5}$ .

<sup>1</sup> Bu yerda va bundan keyin, agar qo‘shimcha shartlar bo‘lmasa, harflar bilan musbat sonlar belgilangan deb hisoblaymiz.

149. Ifodani soddallashtiring:

$$1) \sqrt[3]{a^6 b^7} : \sqrt[3]{ab^2};$$

$$2) \sqrt[3]{81x^4 y} : \sqrt[3]{3xy};$$

$$3) \sqrt[3]{\frac{3x}{y^2}} : \sqrt[3]{\frac{y}{9x^2}};$$

$$4) \sqrt[4]{\frac{2b}{a^3}} : \sqrt[4]{\frac{a}{8b^3}}.$$

Hisoblang (150–151):

$$150. 1) (\sqrt[6]{7^3})^2; \quad 2) (\sqrt[6]{9})^{-3}; \quad 3) (10\sqrt{32})^2; \quad 4) (\sqrt[8]{16})^{-4}.$$

$$151. 1) \sqrt{\sqrt[3]{729}}; \quad 2) \sqrt{\sqrt{1024}}; \quad 3) \sqrt[3]{\sqrt[3]{9}} \cdot \sqrt[4]{3^7}; \quad 4) \sqrt[4]{\sqrt[3]{25}} \cdot \sqrt[5]{5^5}.$$

152. Ifodalarni soddallashtiring:

$$1) (\sqrt[3]{x})^6; \quad 2) (\sqrt[3]{y^2})^3; \quad 3) (\sqrt{a} \cdot \sqrt[3]{b})^6;$$

$$4) (\sqrt[3]{a^2} \cdot \sqrt[4]{b^3})^{12}; \quad 5) (\sqrt{\sqrt[3]{a^2 b}})^6; \quad 6) (\sqrt[4]{\sqrt[3]{27a^3}})^4.$$

Hisoblang (153–155):

$$153. 1) \sqrt[3]{\frac{3}{2}} \cdot \sqrt[3]{2\frac{1}{4}}; \quad 2) \sqrt[4]{\frac{3}{4}} \cdot \sqrt[4]{6\frac{3}{4}}; \quad 3) \sqrt[4]{15\frac{5}{8}} : \sqrt[4]{\frac{2}{5}};$$

$$4) \sqrt[3]{22\frac{1}{2}} \cdot \sqrt[3]{6\frac{2}{3}}; \quad 5) (\sqrt[3]{\sqrt{27}})^2; \quad 6) (\sqrt[3]{\sqrt{16}})^3.$$

$$154. 1) \sqrt[3]{\frac{ab^2}{c}} \cdot \sqrt[3]{\frac{a^5 b}{c^2}}; \quad 2) \sqrt[5]{\frac{8a^3}{b^2}} \cdot \sqrt[5]{\frac{4a^7}{b^3}}; \quad 3) \frac{\sqrt[4]{a^2 b^2 c} \cdot \sqrt[4]{a^3 b^3 c^2}}{\sqrt[4]{abc^2}};$$

$$4) \frac{\sqrt[3]{2a^4 b} \cdot \sqrt[3]{4ab}}{2b\sqrt[3]{a^2 b^2}}; \quad 5) (\sqrt[3]{a^3})^5 \cdot (\sqrt[3]{b^2})^3; \quad 6) (\sqrt[4]{a^3 b^3})^4 : (\sqrt[3]{ab^2})^6.$$

$$155. 1) \frac{\sqrt[3]{49} \cdot \sqrt[3]{112}}{\sqrt[3]{250}}; \quad 2) \frac{\sqrt[4]{54} \cdot \sqrt[4]{120}}{\sqrt[4]{5}};$$

$$3) \frac{\sqrt[4]{32}}{\sqrt[4]{2}} + \sqrt[6]{27} - \sqrt{\sqrt[3]{64}}; \quad 4) \sqrt[3]{3\frac{3}{8}} + \sqrt[4]{18} \sqrt[4]{4\frac{1}{2}} - \sqrt{\sqrt{256}};$$

$$5) \sqrt[3]{11 - \sqrt{57}} \cdot \sqrt[3]{11 + \sqrt{57}}; \quad 6) \sqrt[4]{17 - \sqrt{33}} \cdot \sqrt[4]{17 + \sqrt{33}}.$$

Ifodani soddalashtiring (156–157):

156. 1)  $\sqrt[3]{2ab} \cdot \sqrt[3]{4a^2b} \cdot \sqrt[3]{27b}$ ;

2)  $\sqrt[4]{abc} \cdot \sqrt[4]{a^3b^2c} \cdot \sqrt[4]{b^5c^2}$ ;

3)  $\frac{\sqrt[5]{a^3b^2} \cdot \sqrt[5]{3a^2b^3}}{\sqrt[5]{3ab}}$ ;

4)  $\frac{\sqrt[4]{8x^2y^5} \cdot \sqrt[4]{4x^3y}}{\sqrt[4]{2xy^2}}$ .

157. 1)  $\sqrt[3]{3a^{18}} + (\sqrt[3]{3a^4})^3$ ;

2)  $(\sqrt[3]{x^2})^3 + 2(\sqrt[4]{x})^8$ ;

3)  $2\sqrt{\sqrt{a^4b^8}} - (\sqrt[3]{\sqrt{a^3b^6}})^2$ ;

4)  $\sqrt[3]{\sqrt{x^6y^{12}}} - (\sqrt[5]{xy^2})^5$ ;

5)  $(\sqrt[4]{x^8y^2})^4 - (\sqrt[4]{x^2y^8})^2$ ;

6)  $((\sqrt[5]{a^5a})^5 - \sqrt[5]{a}) : \sqrt[10]{a^2}$ .

158. Hisoblang:

1)  $\frac{\sqrt[3]{3} \cdot \sqrt[3]{9}}{\sqrt[6]{3}}$ ;

2)  $\frac{\sqrt[3]{7} \cdot \sqrt[4]{343}}{\sqrt[12]{7}}$ ;

3)  $(\sqrt[3]{4} - \sqrt[3]{10} + \sqrt[3]{25})(\sqrt[3]{2} + \sqrt[3]{5})$ ;

4)  $(\sqrt[3]{9} + \sqrt[3]{6} + \sqrt[3]{4})(\sqrt[3]{3} - \sqrt[3]{2})$ .

159. Isbotlang:  $\sqrt{4+2\sqrt{3}} - \sqrt{4-2\sqrt{3}} = 2$ .

## 12- §.

## RATSIONAL KO'RSATKICHLI DARAJA

1-masala. Hisoblang:  $\sqrt[4]{5^{12}}$ .

$\Delta 5^{12} = (5^3)^4$  bo'lgani uchun  $\sqrt[4]{5^{12}} = \sqrt[4]{(5^3)^4} = 5^3 = 125$ .  $\blacktriangle$

Shunday qilib,  $\sqrt[4]{5^{12}} = 5^{\frac{12}{4}}$ .

Shunga o'xshash,  $\sqrt[5]{7^{15}} = 7^{\frac{15}{5}}$  ekanligini ko'rsatish mumkin.

Umuman, agar  $n$  – natural son,  $n \geq 2$ ,  $m$  – butun son va  $\frac{m}{n}$

**!** butun son bo'lsa, u holda  $a > 0$  bo'lganda quyidagi tenglik to'g'ri bo'ladi:

$$\sqrt[n]{a^m} = a^{\frac{m}{n}}. \quad (1)$$

○ Shartga ko'ra  $\frac{m}{n}$  — butun son, ya'ni  $m$  ni  $n$  ga bo'lishda  $k$  butun son hosil bo'ladi. Bu holda  $\frac{m}{n} = k$  tenglikdan  $m = kn$  ekanligi kelib chiqadi. Darajaning va arifmetik ildizning xossalarini qo'llab, quyidagini hosil qilamiz:

$$\sqrt[n]{a^m} = \sqrt[n]{a^{kn}} = \sqrt[n]{(a^k)^n} = a^k = a^{\frac{m}{n}}. \bullet$$

**Bordi-yu, agar  $\frac{m}{n}$  butun son bo'lmasa, u holda  $a^{\frac{m}{n}}$  (bunda  $a > 0$ ) daraja (1) formula to'g'riligicha qoladigan qilib ta'riflanadi, ya'ni bu holda**

$$a^{\frac{m}{n}} = \sqrt[n]{a^{\frac{m}{n}}} \quad (2)$$

**deb hisoblanadi.**

Shunday qilib, (2) formula istalgan butun  $m$  va istalgan natural  $n \geq 2$  va  $a > 0$  son uchun to'g'ri bo'ladi. Masalan,

$$16^{\frac{3}{4}} = \sqrt[4]{16^3} = \sqrt[4]{2^{12}} = 2^3 = 8;$$

$$7^{\frac{5}{4}} = \sqrt[4]{7^5} = \sqrt[4]{7^4 \cdot 7} = 7\sqrt[4]{7};$$

$$27^{-\frac{2}{3}} = \sqrt[3]{27^{-2}} = \sqrt[3]{\frac{1}{27^2}} = \frac{\sqrt[3]{1}}{\sqrt[3]{3^6}} = \frac{1}{3^2} = \frac{1}{9}.$$

$r$  ratsional son — bu  $\frac{m}{n}$  ko'rinishidagi son ekanligini, bunda  $m$  — butun son,  $n$  — natural son, ya'ni  $r = \frac{m}{n}$  bo'lishini eslatib o'tamiz. Bu holda (2) formula bo'yicha  $a^r = a^{\frac{m}{n}} = \sqrt[n]{a^m}$  ni hosil qilamiz. Shunday qilib, daraja istalgan ratsional ko'rsatkich va istalgan musbat asos uchun aniqlandi. Agar  $r = \frac{m}{n} > 0$  bo'lsa, u holda  $\sqrt[n]{a^m}$  ifoda faqat  $a > 0$  bo'lgandagina emas, balki  $a = 0$  bo'lganda ham ma'noga ega bo'ladi.  $a = 0$  bo'lsa,  $\sqrt[n]{0^m} = 0$ . Shuning uchun  $r > 0$  bo'lganda  $0^r = 0$  tenglik o'rinli deb hisoblanadi.

(1) va (2) formulalardan foydalanib, ratsional ko'rsatkichli darajani ildiz shaklida, va aksincha, tasvirlash mumkin.

(2) formuladan va ildizning xossalaridan

$$a^{\frac{m}{n}} = a^{\frac{mk}{nk}}$$

tenglik kelib chiqishini ta'kidlaymiz, bunda  $a > 0$ ,  $m$  — butun son va  $n, k$  — natural sonlar.

Masalan,  $7^{\frac{3}{4}} = 7^{\frac{6}{8}} = 7^{\frac{9}{12}}$ .

*Natural ko'rsatkichli darajaning barcha xossalari istalgan ratsional ko'rsatkichli va musbat asosli darajalar uchun to'g'ri bo'lishini ko'rsatish mumkin. Chunonchi, istalgan ratsional  $p$  va  $q$  sonlar va istalgan  $a > 0$  va  $b > 0$  uchun quyidagi tengliklar to'g'ri bo'ladi:*

1)  $a^p \cdot a^q = a^{p+q}$ ,                      4)  $(ab)^p = a^p b^p$ ,  
2)  $a^p : a^q = a^{p-q}$ ,                      5)  $\left(\frac{a}{b}\right)^p = \frac{a^p}{b^p}$ .  
3)  $(a^p)^q = a^{pq}$ ,

Bu xossalar ildizlarning xossalaridan kelib chiqadi. Masalan,  $a^p \cdot a^q = a^{p+q}$  xossani isbotlaylik.

○ Aytaylik,  $p = \frac{m}{n}$ ,  $q = \frac{k}{l}$  (bunda  $n$  va  $l$  — natural sonlar,  $m$  va  $k$  — butun sonlar) bo'lsin.

$$a^{\frac{m}{n}} \cdot a^{\frac{k}{l}} = a^{\frac{m}{n} + \frac{k}{l}} \quad (3)$$

ekanligini isbotlash kerak.

$\frac{m}{n}$  va  $\frac{k}{l}$  kasrlarni umumiy maxrajga keltirib, (3) tenglikning chap qismini

$$a^{\frac{m}{n}} \cdot a^{\frac{k}{l}} = a^{\frac{ml}{nl}} \cdot a^{\frac{kn}{nl}}$$

ko'rinishida yozamiz.



4-masala.. Ifodani soddalashtiring:  $\frac{a^{\frac{1}{3}} - a^{\frac{7}{3}}}{a^{\frac{1}{3}} - a^{\frac{4}{3}}} - \frac{a^{-\frac{1}{3}} - a^{\frac{5}{3}}}{a^{\frac{2}{3}} + a^{-\frac{1}{3}}}$ .

$$\begin{aligned} \Delta \quad \frac{a^{\frac{1}{3}} - a^{\frac{7}{3}}}{a^{\frac{1}{3}} - a^{\frac{4}{3}}} - \frac{a^{-\frac{1}{3}} - a^{\frac{5}{3}}}{a^{\frac{2}{3}} + a^{-\frac{1}{3}}} &= \frac{a^{\frac{1}{3}}(1 - a^2)}{a^{\frac{1}{3}}(1 - a)} - \frac{a^{-\frac{1}{3}}(1 - a^2)}{a^{-\frac{1}{3}}(1 + a)} = \\ &= 1 + a - (1 - a) = 2a. \quad \blacktriangle \end{aligned}$$

$3^{\sqrt{2}}$  misolida *irratsional ko'rsatkichli darajani* qanday kiritish mumkinligini ko'rsatamiz.  $\sqrt{2}$  ning taqribiy qiymatlarini 0,1; 0,01; 0,001; ... gacha aniqlik bilan ketma-ket yozib chiqamiz. U holda quyidagi ketma-ketlik hosil bo'ladi:

$$1,4; 1,41; 1,414; 1,4142; \dots$$

3 sonining daraja ko'rsatkichlari ketma-ketligini shu ratsional ko'rsatkichlar bilan yozib chiqamiz:

$$3^{1,4}; 3^{1,41}; 3^{1,414}; 3^{1,4142}; \dots$$

Bu darajalar  $3^{\sqrt{2}}$  kabi belgilanadigan biror haqiqiy sonning ketma-ket taqribiy qiymatlari ekanini ko'rsatish mumkin:

$$\begin{aligned} 3^{1,4} &= \underline{4,6555355}, \\ 3^{1,41} &= \underline{4,7069644}, \\ 3^{1,414} &= \underline{4,7276942}, \\ 3^{1,4142} &= \underline{4,7287329}, \\ 3^{\sqrt{2}} &\approx \underline{4,7288033}. \end{aligned}$$

Musbat  $a$  asosli va istalgan irratsional ko'rsatkichli  $a^b$  daraja shunga o'xshash ta'riflanadi. Shunday qilib, endi musbat asosli daraja istalgan haqiqiy ko'rsatkich uchun ta'riflandi, buning ustiga haqiqiy ko'rsatkichli darajaning xossalari ratsional ko'rsatkichli darajaning xossalari kabidir.

### Mashqlar

160. (Og'zaki). Ratsional ko'rsatkichli daraja shaklida tasvirlang:

$$1) \sqrt{x^3}; \quad 2) \sqrt[3]{a^4}; \quad 3) \sqrt[4]{b^3}; \quad 4) \sqrt[5]{x^{-1}}; \quad 5) \sqrt[6]{a}; \quad 6) \sqrt[7]{b^{-3}}.$$

161. (Og'zaki). Butun ko'rsatkichli darajaning ildizi shaklida tasvirlang:

1)  $x^{\frac{1}{4}}$ ; 2)  $y^{\frac{2}{5}}$ ; 3)  $a^{-\frac{5}{6}}$ ; 4)  $b^{-\frac{1}{3}}$ ; 5)  $(2x)^{\frac{1}{2}}$ ; 6)  $(3b)^{-\frac{2}{3}}$ .

Hisoblang (162–165):

162. 1)  $64^{\frac{1}{2}}$ ; 2)  $27^{\frac{1}{3}}$ ; 3)  $8^{\frac{2}{3}}$ ; 4)  $81^{\frac{3}{4}}$ ; 5)  $16^{-0.75}$ ; 6)  $9^{-1.5}$ .

163. 1)  $2^{\frac{4}{5}} \cdot 2^{\frac{11}{5}}$ ; 2)  $5^{\frac{2}{7}} \cdot 5^{\frac{5}{7}}$ ; 3)  $9^{\frac{2}{3}} : 9^{\frac{1}{3}}$ ;

4)  $4^{\frac{1}{3}} : 4^{\frac{5}{6}}$ ; 5)  $(7^{-3})^{-\frac{2}{3}}$ ; 6)  $(8^{\frac{1}{12}})^{-4}$ .

164. 1)  $9^{\frac{2}{5}} \cdot 27^{\frac{2}{5}}$ ; 2)  $7^{\frac{2}{3}} \cdot 49^{\frac{2}{3}}$ ; 3)  $144^{\frac{3}{4}} : 9^4$ ; 4)  $150^{\frac{3}{2}} : 6^{\frac{3}{2}}$ .

165. 1)  $(\frac{1}{16})^{-0.75} + (\frac{1}{8})^{-\frac{4}{3}}$ ; 2)  $(0,04)^{-1.5} - (0,125)^{-\frac{2}{3}}$ ;

3)  $8^{\frac{9}{7}} : 8^{\frac{2}{7}} - 3^{\frac{6}{5}} \cdot 3^{\frac{4}{5}}$ ; 4)  $(5^{-\frac{2}{5}})^{-5} + ((0,2)^{\frac{3}{4}})^{-4}$ .

166. Hisoblang:

1)  $a = 0,09$  bo'lganda  $\sqrt[3]{a} \cdot \sqrt[4]{a}$  ning qiymatini;

2)  $b = 27$  bo'lganda  $\sqrt{b} : \sqrt[6]{b}$  ning qiymatini;

3)  $b = 1,3$  bo'lganda  $\frac{\sqrt{b} \cdot \sqrt[3]{b^2}}{\sqrt[6]{b}}$  ning qiymatini;

4)  $a = 2,7$  bo'lganda  $\sqrt[3]{a} \cdot \sqrt[4]{a} \cdot \sqrt[12]{a^5}$  ning qiymatini.

167. Ratsional ko'rsatkichli daraja shaklida tasvirlang:

1)  $a^{\frac{1}{3}} \cdot \sqrt{a}$ ; 2)  $b^{\frac{1}{2}} \cdot b^{\frac{1}{3}} \cdot \sqrt[6]{b}$ ; 3)  $\sqrt[3]{b} : b^{\frac{1}{6}}$ ;

4)  $a^{\frac{3}{4}} : \sqrt[3]{a}$ ; 5)  $x^{1.7} \cdot x^{2.8} : \sqrt{x^5}$ ; 6)  $y^{-3.8} : y^{-2.3} \cdot \sqrt{y^3}$ .



Ifodani soddallashtiring (168–169):

168. 1)  $(a^4)^{-\frac{3}{4}} \cdot (b^{-\frac{2}{3}})^{-6}$ ;      2)  $\left(\left(\frac{a^6}{b^{-3}}\right)^4\right)^{\frac{1}{12}}$ .

169. 1)  $\frac{a^{\frac{4}{3}}(a^{-\frac{1}{3}} + a^{\frac{2}{3}})}{a^4(a^4 + a^{-\frac{1}{4}})}$ ;      2)  $\frac{b^{\frac{5}{3}}(\sqrt[3]{b^4} - \sqrt[3]{b^{-1}})}{b^{\frac{2}{3}}(\sqrt[3]{b} - \sqrt[3]{b^{-2}})}$ ;

3)  $\frac{a^{\frac{5}{3}}b^{-1} - ab^{-\frac{1}{3}}}{\sqrt[3]{a^2} - \sqrt[3]{b^2}}$ ;      4)  $\frac{a^{\frac{1}{3}}\sqrt{b} + b^{\frac{1}{3}}\sqrt{a}}{\sqrt[3]{a} + \sqrt[3]{b}}$ .

170. Hisoblang:

1)  $(2^{\frac{5}{3}} \cdot 3^{-\frac{1}{3}} - 3^{\frac{5}{3}} \cdot 2^{-\frac{1}{3}}) \cdot \sqrt[3]{6}$ ;      2)  $(5^{\frac{1}{4}} : 2^{\frac{3}{4}} - 2^{\frac{1}{4}} : 5^{\frac{3}{4}}) \cdot \sqrt[4]{1000}$ .

171. Ifodalarni soddallashtiring:

1)  $a^{\frac{1}{9}}\sqrt[9]{a^3\sqrt{a}}$ ;      2)  $b^{\frac{1}{12}}\sqrt[12]{b^4\sqrt{b}}$ ;      3)  $(\sqrt[3]{ab^{-2}} + (ab)^{\frac{1}{6}})^6\sqrt{ab^4}$ ;

4)  $(\sqrt[3]{a} + \sqrt[3]{b})(a^{\frac{2}{3}} + b^{\frac{2}{3}} - \sqrt[3]{ab})$ ;      5)  $\frac{x-y}{\frac{1}{x^2+y^2}}$ ;      6)  $\frac{\sqrt{a}-\sqrt{b}}{\frac{1}{a^4-b^4}}$ ;

7)  $\frac{m^{\frac{1}{2}}+n^{\frac{1}{2}}}{m+2\sqrt{mn}+n}$ ;      8)  $\frac{c-2c^{\frac{1}{2}}+1}{\sqrt{c}-1}$ .

Ifodalarni soddallashtiring (172–174):

172. 1)  $(1 - 2\sqrt{\frac{b}{a}} + \frac{b}{a}) : (a^{\frac{1}{2}} - b^{\frac{1}{2}})^2$ ;      2)  $(a^{\frac{1}{3}} + b^{\frac{1}{3}}) : (2 + \sqrt[3]{\frac{a}{b}} + \sqrt[3]{\frac{b}{a}})$ ;

3)  $\frac{a^{\frac{1}{4}} - a^{\frac{9}{4}}}{a^4 - a^4} - \frac{b^{-\frac{1}{2}} - b^{\frac{3}{2}}}{b^2 - b^{-\frac{1}{2}}}$ ;      4)  $\frac{\sqrt{a} - a^{-\frac{1}{2}}b}{1 - \sqrt{a^{-1}b}} - \frac{\sqrt[3]{a^2} - a^{-\frac{1}{3}}b}{\sqrt[6]{a} + a^{-\frac{1}{3}}\sqrt[6]{b}}$ .

173. 1)  $\frac{a^{\frac{3}{2}}}{\sqrt{a} + \sqrt{b}} - \frac{ab^{\frac{1}{2}}}{\sqrt{b} - \sqrt{a}} - \frac{2a^2 - 4ab}{a-b}$ ;      2)  $\frac{3xy - y^2}{x-y} - \frac{y\sqrt{y}}{\sqrt{x} - \sqrt{y}} - \frac{y\sqrt{x}}{\sqrt{x} + \sqrt{y}}$ ;

3)  $\frac{1}{\sqrt[3]{a} + \sqrt[3]{b}} - \frac{\sqrt[3]{a} + \sqrt[3]{b}}{a^{\frac{2}{3}} - \sqrt[3]{ab} + b^{\frac{2}{3}}}$ ;      4)  $\frac{\sqrt[3]{a^2} - \sqrt[3]{b^2}}{\sqrt[3]{a} - \sqrt[3]{b}} - \frac{a+b}{a^{\frac{2}{3}} + \sqrt[3]{ab} + b^{\frac{2}{3}}}$ .

$$174. 1) \frac{a-b}{\sqrt[3]{a}-\sqrt[3]{b}} - \frac{a+b}{a^{\frac{1}{3}}+b^{\frac{1}{3}}};$$

$$2) \frac{a+b}{a^{\frac{2}{3}}-a^{\frac{1}{3}}b^{\frac{1}{3}}+b^{\frac{2}{3}}} - \frac{a-b}{a^{\frac{2}{3}}+a^{\frac{1}{3}}b^{\frac{1}{3}}+b^{\frac{2}{3}}};$$

$$3) \frac{a^{\frac{2}{3}}+b^{\frac{2}{3}}}{a-b} - \frac{1}{a^{\frac{1}{3}}-b^{\frac{1}{3}}};$$

$$4) \frac{a^{\frac{1}{3}}-b^{\frac{1}{3}}}{a+b} + \frac{1}{a^{\frac{2}{3}}-a^{\frac{1}{3}}b^{\frac{1}{3}}+b^{\frac{2}{3}}}.$$

### 13- §.

### SONLI TENGSIZLIKLARNI DARAJAGA KO'TARISH

8-sinf «Algebra» kursida chap va o'ng qismlari musbat bo'lgan bir xil belgili tengsizliklarni hadlab ko'paytirilganda shu belgili tengsizlik hosil bo'lishi ko'rsatilgan edi.



**Bundan, agar  $a > b > 0$  va  $n$  natural son bo'lsa, u holda  $a^n > b^n$  bo'lishi kelib chiqadi.**

○ Shartga ko'ra  $a > 0$ ,  $b > 0$ .  $n$  ta bir xil  $a > b$  tengsizlikni hadlab ko'paytirib, hosil qilamiz:  $a^n > b^n$ . ●

**1-masala.**  $(0,43)^5$  va  $\left(\frac{3}{7}\right)^5$  sonlarini taqqoslang.

△ 0,001 gacha aniqlik bilan  $\frac{3}{7} \approx 0,428$  bo'lgani uchun  $0,43 > \frac{3}{7}$

bo'ladi. Shuning uchun  $(0,43)^5 > \left(\frac{3}{7}\right)^5$ . ▲

**Chap va o'ng qismlari musbat bo'lgan tengsizlikni istalgan ratsional darajaga ko'tarish mumkin:**

agar  $a > b > 0$ ,  $r > 0$  bo'lsa, u holda



$$a^r > b^r \quad (1)$$

bo'ladi;

agar  $a > b > 0$ ,  $r < 0$  bo'lsa, u holda

$$a^r < b^r \quad (2)$$

bo'ladi.

1- xossani isbotlaymiz.

○ Avval (1) xossaning  $r = \frac{1}{n}$  bo'lganda to'g'riligini, keyin esa umumiy hol uchun  $r = \frac{m}{n}$  bo'lganda to'g'riligini isbotlaymiz.

a) Aytaylik,  $r = \frac{1}{n}$  bo'lsin, bunda  $n$  — birdan katta natural son,  $a > 0$ ,  $b > 0$ . Shartga ko'ra  $a > b$ .  $a^{\frac{1}{n}} > b^{\frac{1}{n}}$  ekanligini isbotlash kerak. Faraz qilaylik, bu noto'g'ri, ya'ni  $a^{\frac{1}{n}} \leq b^{\frac{1}{n}}$  bo'lsin. U holda bu tengsizlikni  $n$  natural darajaga ko'tarib,  $a \leq b$  ni hosil qilamiz, bu esa  $a > b$  shartga zid. Demak,  $a > b > 0$  dan  $a^{\frac{1}{n}} > b^{\frac{1}{n}}$  ekanligi kelib chiqadi.

b) Aytaylik,  $r = \frac{m}{n}$  bo'lsin, bunda  $m$  va  $n$  — natural sonlar. U holda  $a > b > 0$  shartdan, isbot qilganimizga ko'ra  $a^{\frac{1}{n}} > b^{\frac{1}{n}}$  ekanligi kelib chiqadi. Bu tengsizlikni  $m$  natural darajaga ko'tarib, hosil qilamiz:

$$\left(a^{\frac{1}{n}}\right)^m > \left(b^{\frac{1}{n}}\right)^m, \text{ ya'ni } a^{\frac{m}{n}} > b^{\frac{m}{n}}. \bullet$$

Masalan,  $5^{\frac{2}{7}} > 3^{\frac{2}{7}}$ , chunki  $5 > 3$ ;  $2^{\frac{3}{4}} < 4^{\frac{3}{4}}$ , chunki  $2 < 4$ ;  $\sqrt[5]{7^2} > \sqrt[5]{6^2}$ , chunki  $7 > 6$ .

Endi (2) xossani isbotlaymiz.

○ Agar  $r < 0$  bo'lsa, u holda  $-r > 0$  bo'ladi. (1) xossaga ko'ra  $a > b > 0$  shartdan  $a^{-r} > b^{-r}$  ekanligi kelib chiqadi. Bu tengsizlikning ikkala qismini musbat  $a'b'$  songa ko'paytirib,  $b^r > a^r$  ni hosil qilamiz, ya'ni  $a^r < b^r$ . ●

Masalan,  $(0,7)^{-8} < (0,6)^{-8}$ , chunki  $0,7 > 0,6$ ;  $13^{-0,6} > 15^{-0,6}$ , chunki  $13 < 15$ ;  $\sqrt[4]{8^{-3}} < \sqrt[4]{7^{-3}}$ , chunki  $8 > 7$ .

Oliy matematika kursida (1) xossa istalgan musbat  $r$  haqiqiy son uchun, (2) xossa esa istalgan manfiy  $r$  haqiqiy son uchun to'g'ri ekanligi isbotlanadi. Masalan,

$$\left(\frac{8}{9}\right)^{\sqrt{2}} > \left(\frac{7}{8}\right)^{\sqrt{2}}, \text{ chunki } \frac{8}{9} > \frac{7}{8}; \quad \left(\frac{7}{8}\right)^{-\sqrt{3}} < \left(\frac{6}{7}\right)^{-\sqrt{3}}, \text{ chunki } \frac{7}{8} > \frac{6}{7}.$$

Qat'iy tengsizliklarni ( $>$  yoki  $<$  belgisi) darajaga ko'tarishning qarab o'tilgan xossalari noqat'iy tengsizliklar ( $\geq$  yoki  $\leq$  belgisi) uchun ham to'g'ri bo'lishini ta'kidlab o'tamiz.

**!** Shunday qilib, agar tengsizlikning ikkala qismi musbat bo'lsa, u holda uni musbat darajaga ko'targanda tengsizlik belgisi saqlanadi, manfiy darajaga ko'targanda esa tengsizlik belgisi qarama-qarshisiga o'zgaradi.

Qat'iy tengsizliklar uchun  $>$  va  $<$  belgilari, noqat'iy tengsizliklar uchun esa  $\geq$  va  $\leq$  belgilari qarama-qarshi belgilar bo'lishini eslatib o'tamiz.

**2-masala.** Sonlarni taqqoslang:

$$1) \left(\frac{17}{18}\right)^{-\frac{1}{3}} \text{ va } \left(\frac{18}{17}\right)^{-\frac{1}{3}}; \quad 2) \left(\frac{6}{7}\right)^{\sqrt{2}} \text{ va } (0,86)^{\sqrt{2}}.$$

$$\triangle 1. \frac{17}{18} < 1 \text{ va } \frac{18}{17} > 1 \text{ bo'lgani uchun } \frac{17}{18} < \frac{18}{17} \text{ bo'ladi.}$$

Bu tengsizlikni manfiy  $\left(-\frac{1}{3}\right)$  darajaga ko'tarib, hosil qilamiz:

$$\left(\frac{17}{18}\right)^{-\frac{1}{3}} > \left(\frac{18}{17}\right)^{-\frac{1}{3}}.$$

2. Darajalarning asoslarini taqqoslaymiz.  $\frac{6}{7} = 0,857\dots$  bo'lgani uchun  $\frac{6}{7} < 0,86$  bo'ladi. Bu tengsizlikni musbat  $\sqrt{2}$  darajaga ko'tarib, quyidagini hosil qilamiz:

$$\left(\frac{6}{7}\right)^{\sqrt{2}} < 0,86^{\sqrt{2}}. \blacktriangle$$

**3-masala.** Tenglamani yeching:  $10^x = 1$ .

$\triangle x = 0$  son bu tenglamaning ildizi bo'ladi, chunki  $10^0 = 1$ . Boshqa ildizlari yo'qligini ko'rsatamiz.

Berilgan tenglamani  $10^x = 1^x$  ko'rinishida yozamiz.

Agar  $x > 0$  bo'lsa, u holda  $10^x > 1^x$  va, demak, tenglama musbat ildizlarga ega emas.

Agar  $x < 0$  bo'lsa, u holda  $10^x < 1^x$  va, demak, tenglama manfiy ildizlarga ega emas.

Shunday qilib,  $x = 0$  berilgan  $10^x = 1$  tenglamaning yagona ildizi ekan.  $\blacktriangle$

Shunga o'xshash,  $a^x = 1$  ( $a > 0$ ,  $a \neq 1$ ) tenglama yagona  $x = 0$  ildizga ega bo'lishi isbotlanadi. Bundan,

$$a^x = a^y \quad (3)$$

tenglik  $x = y$  bo'lgandagina to'g'ri bo'lishi kelib chiqadi, bu yerda  $a > 0$ ,  $a \neq 1$ .

○ (3) tenglikni  $a^{-y}$  ga ko'paytirib,  $a^{x-y} = 1$  ni hosil qilamiz, bundan  $x = y$ . ●

**4-masala.**  $3^{2x-1} = 9$  tenglamani yeching.

$$\triangle 3^{2x-1} = 3^2, \text{ bundan } 2x - 1 = 2, x = 1,5. \blacktriangle$$

$a^x = b$  tenglamani qaraymiz, bunda  $a > 0$ ,  $a \neq 1$ ,  $b > 0$ .

Bu tenglama yagona  $x_0$  ildizga ega ekanligini isbotlash mumkin.  $x_0$  son  $a$  asos bo'yicha  $b$  sonning logarifmi deyiladi va  $\log_a b$  kabi belgilanadi. Masalan,  $3^x = 9$  tenglamaning ildizi 2 soni bo'ladi, ya'ni  $\log_3 9 = 2$ . Xuddi shunday,  $\log_2 16 = 4$ , chunki  $2^4 = 16$ ,  $\log_5 \frac{1}{5} = -1$ , chunki

$$5^{-1} = \frac{1}{5}; \log_{\frac{1}{3}} 27 = -3, \text{ chunki } \left(\frac{1}{3}\right)^{-3} = 27.$$

$b$  sonning 10 asosga ko'ra logarifmi *o'nli logarifm* deyiladi va  $\lg b$  kabi belgilanadi. Masalan,  $\lg 100 = 2$ , chunki  $10^2 = 100$ ;  $\lg 0,001 = -3$ , chunki  $10^{-3} = 0,001$ .

### Mashqlar

**175.** (Og'zaki). Sonlarni taqqoslang:

$$1) 2^{\frac{1}{3}} \text{ va } 3^{\frac{1}{3}}; \quad 2) 5^{-\frac{4}{5}} \text{ va } 3^{-\frac{4}{5}}; \quad 3) 5^{\sqrt{3}} \text{ va } 7^{\sqrt{3}}; \quad 4) 21^{-\sqrt{2}} \text{ va } 31^{-\sqrt{2}}.$$

**176.** Sonlarni taqqoslang:

$$1) (0,88)^{\frac{1}{6}} \text{ va } \left(\frac{6}{11}\right)^{\frac{1}{6}}; \quad 2) \left(\frac{5}{12}\right)^{-\frac{1}{4}} \text{ va } (0,41)^{-\frac{1}{4}};$$

$$3) (4,09)^{\frac{3}{2}} \text{ va } \left(4\frac{3}{25}\right)^{\frac{3}{2}}; \quad 4) \left(\frac{11}{12}\right)^{-\sqrt{5}} \text{ va } \left(\frac{12}{13}\right)^{-\sqrt{5}}.$$

**177.** Tenglamalarni yeching:

$$1) 6^{2x} = 6^{\frac{1}{5}}; \quad 2) 3^x = 27; \quad 3) 7^{1-3x} = 7^{10};$$

$$4) 2^{2x+1} = 32; \quad 5) 4^{2+x} = 1; \quad 6) \left(\frac{1}{5}\right)^{4x-3} = 5.$$

178. Sonlarni taqqoslang:

$$1) \sqrt[7]{\left(\frac{1}{2} - \frac{1}{3}\right)^2} \text{ va } \sqrt[7]{\left(\frac{1}{3} - \frac{1}{4}\right)^2}; \quad 2) \sqrt[5]{\left(1\frac{1}{4} - 1\frac{1}{5}\right)^3} \text{ va } \sqrt[5]{\left(1\frac{1}{6} - 1\frac{1}{7}\right)^3}.$$

Tenglamani yeching (179–180):

179. 1)  $3^{2-y} = 27$ ; 2)  $3^{a-2x} = 1$ ; 3)  $9^{\frac{1}{2}x-1} - 3 = 0$ ; 4)  $27^{3-\frac{1}{3}y} - 81 = 0$ .

180. 1)  $\left(\frac{1}{9}\right)^{2x-5} = 3^{5x-8}$ ; 2)  $2^{4x-9} = \left(\frac{1}{2}\right)^{x-4}$ ;

3)  $8^x 4^{x+13} = \frac{1}{16}$ ; 4)  $\frac{25^{x-2}}{\sqrt{5}} = \left(\frac{1}{5}\right)^{x-7.5}$ .

---

181. 1)  $\left(\frac{1}{\sqrt{3}}\right)^{2x+1} = (3\sqrt{3})^x$ ; 2)  $(\sqrt[3]{2})^{x-1} = \left(\frac{2}{\sqrt[3]{2}}\right)^{2x}$ ;

3)  $9^{3x+4} \sqrt{3} = \frac{27^{x-1}}{\sqrt{3}}$ ; 4)  $\frac{8}{(\sqrt{2})^x} = 4^{3x-2} \sqrt{2}$ .

182. Hisoblang:

1)  $\log_7 49$ ; 2)  $\log_2 64$ ; 3)  $\log_{\frac{1}{2}} 4$ ; 4)  $\log_{\frac{1}{27}} \frac{1}{2}$ .

### III bobga doir mashqlar

183. Hisoblang:

1)  $(0,175)^0 + (0,36)^{-2} - 1^{\frac{4}{3}}$ ; 2)  $1^{-0,43} - (0,008)^{\frac{1}{3}} + (15,1)^0$ ;

3)  $\left(\frac{4}{5}\right)^{-2} - \left(\frac{1}{27}\right)^{\frac{1}{3}} + 4 \cdot 379^0$ ; 4)  $(0,125)^{\frac{1}{3}} + \left(\frac{3}{4}\right)^2 - (1,85)^0$ .

184. Hisoblang:

1)  $9,3 \cdot 10^{-6} : (3,1 \cdot 10^{-5})$ ; 2)  $1,7 \cdot 10^{-6} \cdot 3 \cdot 10^7$ ;

3)  $8,1 \cdot 10^{16} \cdot 2 \cdot 10^{-14}$ ; 4)  $6,4 \cdot 10^5 : (1,6 \cdot 10^7)$ ;

5)  $2 \cdot 10^{-1} + \left(6^0 - \frac{1}{6}\right)^{-1} \cdot \left(\frac{1}{3}\right)^{-2} \cdot \left(\frac{1}{3}\right)^3 \cdot \left(-\frac{1}{4}\right)^{-1}$ ;

6)  $3 \cdot 10^{-1} - \left(8^0 - \frac{1}{8}\right)^{-1} \cdot \left(\frac{1}{4}\right)^{-3} \cdot \left(\frac{1}{4}\right)^4 \cdot \left(\frac{5}{7}\right)^{-1}$ .

185. Ifodaning qiymatini toping:

$$1) \left( \frac{x^{\frac{1}{2}} \cdot x^{\frac{5}{6}}}{x^{\frac{1}{6}}} \right)^{-2}, \text{ bunda } x = \frac{7}{9};$$

$$2) \left( \frac{a^{\frac{2}{3}} \cdot a^{\frac{1}{9}}}{a^{\frac{2}{9}}} \right)^{-3}, \text{ bunda } a = 0,1.$$

186. Ifodani soddalashtiring:

$$1) (\sqrt[3]{125x} - \sqrt[3]{8x}) - (\sqrt[3]{27x} - \sqrt[3]{64x}); \quad 2) (\sqrt[4]{x} + \sqrt[4]{16x}) + (\sqrt[4]{81x} - \sqrt[4]{625x});$$

$$3) \left( \frac{3}{\sqrt{1+a}} + \sqrt{1-a} \right) : \frac{3 + \sqrt{1+a}}{\sqrt{1+a}}; \quad 4) \left( 1 - \frac{x}{\sqrt{x^2 - y^2}} \right) : (\sqrt{x^2 - y^2} - x).$$

187. Tenglamani yeching:

$$1) 7^{5x-1} = 49; \quad 2) (0,2)^{1-x} = 0,04;$$

$$3) \left( \frac{1}{3} \right)^{3x+3} = 7^{2x}; \quad 4) 3^{5x-7} = \left( \frac{1}{3} \right)^{2x}.$$

188. Hisoblang:

$$1) \left( \frac{1}{16} \right)^{-0,75} + 10000^{0,25} - \left( 7 \frac{19}{32} \right)^{\frac{1}{5}}; \quad 2) (0,001)^{-\frac{1}{3}} - 2^{-2} \cdot 64^{\frac{2}{3}} - 8^{-\frac{1}{3}};$$

$$3) 27^{\frac{2}{3}} - (-2)^{-2} + \left( 3 \frac{3}{8} \right)^{\frac{1}{3}}; \quad 4) (-0,5)^{-4} - 625 - \left( 2 \frac{1}{4} \right)^{-\frac{1}{2}}.$$

189.  $x$  ning qanday qiymatlarida ifoda ma'noga ega bo'ladi:

$$1) \sqrt[4]{x^2 - 4}; \quad 2) \sqrt[3]{x^2 - 5x + 6}; \quad 3) \sqrt[6]{\frac{x-2}{x+3}};$$

$$4) \sqrt[4]{x^2 - 5x + 6}; \quad 5) \sqrt[8]{x^3 - x}; \quad 6) \sqrt[6]{x^3 - 5x^2 + 6x}?$$

190. Ifodani soddalashtiring:

$$1) \frac{a^{\frac{1}{4}} - a^{-\frac{7}{4}}}{a^{\frac{1}{4}} - a^{-\frac{3}{4}}}; \quad 2) \frac{a^{\frac{4}{3}} - a^{-\frac{2}{3}}}{a^{\frac{1}{3}} - a^{-\frac{2}{3}}}; \quad 3) \frac{b^{\frac{5}{4}} + 2b^{\frac{1}{4}} + b^{-\frac{3}{4}}}{b^{\frac{3}{4}} - b^{-\frac{1}{4}}};$$

$$4) \frac{a^{-\frac{4}{3}}b^{-2} - a^{-2}b^{-\frac{4}{3}}}{a^{-\frac{5}{3}}b^{-2} - b^{-\frac{5}{3}}a^{-2}}; \quad 5) \frac{\sqrt{a^3b^{-1}} - \sqrt{a^{-1}b^3}}{\sqrt{ab^{-1}} - \sqrt{a^{-1}b}}; \quad 6) \frac{a^{\frac{3}{4}}b^{-\frac{1}{4}} - a^{-\frac{1}{4}}b^{\frac{3}{4}}}{a^{\frac{1}{4}}b^{-\frac{1}{4}} - a^{-\frac{1}{4}}b^{\frac{1}{4}}};$$

### O'ZINGIZNI TEKSHIRIB KO'RING!

1. Hisoblang:

$$1) 3^{-5} \cdot 3^{-7} - 2^{-2} \cdot 2^4 + \left( \left( \frac{2}{3} \right)^{-1} \right)^3; \quad 2) \sqrt[5]{3^{10} \cdot 32} - \frac{\sqrt[3]{48}}{\sqrt{2} \cdot \sqrt[3]{3}};$$

$$3) 25^{\frac{3}{2}} \cdot 25^{-1} + (5^3)^{\frac{2}{3}} : 5^3 - 48^{\frac{2}{3}} : 6^{\frac{2}{3}}.$$

2. 8600 va 0,0078 sonlarini standart ko'rinishda yozing hamda ko'paytiring va bo'ling.

3. Ifodalarni soddalashtiring:

$$1) \frac{3x^{-9} \cdot 2x^5}{x^{-4}}; \quad 2) (x^{-1} + y^{-1}) \left( \frac{1}{xy} \right)^{-2}.$$

4.  $\frac{a^{\frac{5}{3}}}{\sqrt[3]{a^2} \cdot a^{\frac{3}{4}}}$  ifodani soddalashtiring va  $a = 81$  bo'lganda uning son qiymatini toping.

5. Sonlarni taqqoslang:

$$(0,78)^{\frac{2}{3}} \text{ va } (0,67)^{\frac{2}{3}}; \quad (3,09)^{-\frac{1}{3}} \text{ va } (3,08)^{-\frac{1}{3}}.$$

?

### III bobga doir sinov (test) mashqlari

1. Hisoblang:  $(-8)^2 - (-5)^3 - (12)^{-1}$ .

$$A) 188 \frac{11}{12}; \quad B) -61 \frac{1}{12}; \quad C) 189 \frac{1}{12}; \quad D) 61 \frac{1}{12}; \quad E) 188 \frac{1}{12}.$$

2. Hisoblang:  $(-0,2)^{-3} + (0,2)^{-2} - (-2)^{-2}$ .

$$A) -150 \frac{1}{4}; \quad B) -100 \frac{1}{4}; \quad C) 99 \frac{1}{4}; \quad D) 11,25; \quad E) -149,75.$$

3. Hisoblang:  $\frac{\sqrt[3]{-16} + \sqrt[3]{54} + \sqrt[3]{128}}{\sqrt[3]{-250}}$ .

$$A) \sqrt[3]{2}; \quad B) 1; \quad C) -1; \quad D) \frac{9}{5}; \quad E) 7\sqrt[3]{2}.$$



4. Hisoblang:  $\sqrt[4]{\frac{(4,15)^3 - (1,61)^3}{2,54}} + 4,15 \cdot 1,61$ .
- A) 3,4; B) 5,76; C) 24; D) 2,4; E) 2,6.
5. Hisoblang:  $\sqrt[3]{\frac{(2,08)^3 + (2,016)^3}{4,096}} - 2,08 \cdot 2,016$ .
- A) 0,064; B) 4,096; C) 1,6; D) 0,8; E) 0,16.
6. Hisoblang:  $\sqrt{2\sqrt{2} + 1} \cdot \sqrt[4]{9 - 4\sqrt{2}}$ .
- A)  $\sqrt{7}$ ; B)  $2\sqrt{15}$ ; C)  $3 - 2\sqrt{2}$ ;  
D) 7; E) to'g'ri javob berilmagan.
7. Hisoblang:  $\sqrt[3]{2 - \sqrt{3}} \cdot \sqrt[6]{7 + 4\sqrt{3}}$ .
- A) -1; B) 1; C)  $3 + 2\sqrt{3}$ ; D)  $5 + 3\sqrt{3}$ ; E)  $3 - 2\sqrt{3}$ .
8. Hisoblang:  $\sqrt[3]{1 + \sqrt{2}} \cdot \sqrt[6]{3 - 2\sqrt{2}}$ .
- A)  $3 - \sqrt{2}$ ; B) -1; C) 1; D)  $2\sqrt{2}$ ; E)  $2 - \sqrt{2}$ .
9. Hisoblang:  $\frac{\sqrt[3]{45 - 29\sqrt{2}} \cdot (3 - \sqrt{2})}{11 - 6\sqrt{2}}$ .
- A)  $5 - \sqrt{2}$ ; B)  $5\sqrt{2}$ ; C) -1;  
D) 1; E) to'g'ri javob berilmagan.
10. Hisoblang:  $\sqrt{\sqrt[3]{64}}$ .
- A) 8; B)  $\sqrt{2}$ ; C)  $2\sqrt{2}$ ; D) -2; E) 2.
11. Hisoblang:  $\sqrt[4]{8^4 \sqrt{16}}$ .
- A) 2; B) -2; C)  $4\sqrt{2}$ ; D) 8; E)  $\sqrt[4]{8}$ .
12. Hisoblang:  $\sqrt[3]{-4} \cdot \sqrt[3]{8}$ .
- A) 2; B) -2; C)  $\sqrt[3]{-4}$ ; D)  $\sqrt[6]{32}$ ; E)  $\sqrt[3]{4}$ .

13. Hisoblang:  $\frac{\sqrt[3]{98} \cdot \sqrt[3]{-112}}{\sqrt[3]{500}}$ .

A)  $-\sqrt[3]{4}$ ; B) 2,84; C) -2,8; D) -1,4; E)  $\sqrt[3]{4}$ .

14.  $a = 125$  bo'lganda  $\sqrt{a} : \sqrt[6]{a}$  ifodaning son qiymatini toping:

A) -25; B) 15; C) -5; D) 5; E) 25.

15.  $a = 0,04$  bo'lganda  $\sqrt[3]{a} \cdot \sqrt[6]{a}$  ifodaning son qiymatini toping:

A) 0,08; B)  $\sqrt[3]{0,4}$ ; C) 0,4; D) -0,2; E) 0,2.

16. Ifodani soddalashtiring:  $(a^5)^{-\frac{4}{5}} \cdot (b^{-\frac{3}{4}})^{-\frac{2}{3}}$ .

A)  $a^{-4} \cdot b^{\frac{1}{2}}$ ; B)  $a^4 \cdot b^{-\frac{1}{2}}$ ; C)  $a^5 \cdot b^2$ ; D)  $a^{-5} \cdot b^{-2}$ ; E)  $a^{-4} \cdot b^2$ .

17. Ifodani soddalashtiring:  $(\sqrt[3]{a} - \sqrt[3]{b}) \cdot (a^{\frac{2}{3}} + \sqrt[3]{ab} + b^{\frac{2}{3}})$ .

A)  $a + b$ ; B)  $a - b$ ; C)  $a^3 + b^3$ ; D)  $a^3 - b^3$ ; E)  $(a + b)^{\frac{1}{3}}$ .

18. Ifodani soddalashtiring:  $(a^{\frac{1}{3}} - b^{\frac{1}{3}}) : \left( \sqrt[3]{\frac{a}{b}} + \sqrt[3]{\frac{b}{a}} - 2 \right)$ .

A)  $\sqrt[3]{ab}$ ; B)  $\sqrt[3]{a} + \sqrt[3]{b}$ ; C)  $\frac{\sqrt[3]{ab}}{\sqrt[3]{a} - \sqrt[3]{b}}$ ; D)  $\frac{\sqrt[3]{a} - \sqrt[3]{b}}{\sqrt[3]{ab}}$ ; E)  $\frac{ab}{a-b}$ .

19. Sonlarni taqqoslang:  $a = \left(\frac{7}{12}\right)^{-\frac{1}{4}}$  va  $b = (0,58)^{-\frac{1}{4}}$ .

A)  $b = a + 0,5$ ; B)  $a = b + 0,8$ ; C)  $b < a$ ; D)  $b > a$ ; E)  $b = a$ .

20. Sonlarni taqqoslang:  $a = (3,09)^{\sqrt{2}}$  va  $b = \left(3\frac{10}{11}\right)^{\sqrt{2}}$ .

A)  $b = a - 0,09$ ; B)  $a = b - 0,09$ ; C)  $a > b$ ; B)  $a = b$ ; E)  $a < b$ .

21. Sonlarni o'sish tartibida joylashtiring:  $a = \sqrt{2}$ ,  $b = \sqrt[3]{3}$ ,  $c = \sqrt[6]{7}$ .

A)  $c < a < b$ ; B)  $c < b < a$ ; C)  $b < a < c$ ; D)  $a < b < c$ ; E)  $b < c < a$ .

22. Sonlarni kamayish tartibida joylashtiring:  $a = \sqrt[3]{2}$ ,  $b = \sqrt[4]{3}$ ,  $c = \sqrt[5]{5}$ .

A)  $a > b > c$ ; B)  $b > c > a$ ; C)  $c > a > b$ ; D)  $b > a > c$ ; E)  $c > b > a$ .



Ratsional ko'rsatkichli daraja I. Nyuton (1643–1727) tomondan kiritilgan. Ixtiyoriy  $\alpha$  haqiqiy son uchun  $a^\alpha$ ,  $a > 0$ , daraja tushunchasi L. Eyler (1707–1783)ning «Analizga kirish» asarida berilgan.

Abu Rayhon Beruniy o'zining mashhur «Qonuni Ma'sudiy» asarida «aylana uzunligining uning diametriga nisbati irratsional son» ekanligini aytadi. Qadimgi Yunonistonda «agar kvadratning tomonini o'lchov birligi qilib olinsa, uning diagonalini ratsional son bilan ifodalab bo'lmasligi» isbotlangan. Miloddan avvalgi V—IV asrlardayoq qadimgi yunon olimlari to'la kvadrat bo'lmagan istalgan  $n$  natural son uchun  $\sqrt{n}$  sonning irratsional ekanini isbotlashgan.

G'iyosiddin Jamshid al-Koshiyning «Arifmetika kaliti» asarida natural sondan ildiz chiqarishning umumiy usuli bayon qilinadi.

$\sqrt[n]{a^n + r}$  ildizni al-Koshiy taqriban  $\sqrt[n]{a^n + r} \approx a + \frac{r}{(a+1)^n - a^n}$  ko'rinishida ifodalaydi, bunda  $a$  – natural son va  $r < (a+1)^n - a^n$ .

Al-Koshiy ildizni aniqroq hisoblash uchun ildiz ostidagi sonni 10 ning mos darajasiga ko'paytirishni taklif etadi:

$\sqrt[n]{N} = \frac{\sqrt[n]{10^{mn} \cdot N}}{10^m}$ . Kasrdan ildiz chiqarishda esa ushbu qoidadan

foydalanadi:  $\sqrt[n]{\frac{M}{N}} = \frac{\sqrt[n]{M \cdot N^{n-1}}}{N}$ .

Shu bilan birga, Al-Koshiy ildizlar ko'paytmasini umumiy ko'rsatkichga keltirish qoidasini bayon etgan:

$$\sqrt[n]{a} \cdot \sqrt[k]{b} = \sqrt[kn]{a^k} \cdot \sqrt[kn]{b^n} = \sqrt[kn]{a^k \cdot b^n}.$$

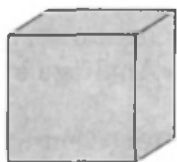

$$V = x^3$$

$$x = \sqrt[3]{V}$$

$$x = V^{\frac{1}{3}}$$



$$S = \pi r^2$$

$$r = \sqrt{\frac{S}{\pi}}$$

## 14- §.

## FUNKSIYANING ANIQLANISH SOHASI

Siz 8- sinfda funksiya tushunchasi bilan tanishgansiz. Shu tushunchani eslatib o'tamiz.



Agar sonlarning biror to'plamidan olingan  $x$  ning har bir qiymatiga  $y$  son mos keltirilgan bo'lsa, shu to'plamda  $y(x)$  funksiya berilgan deyiladi. Bunda  $x$  erkli o'zgaruvchi yoki argument,  $y$  esa erksiz o'zgaruvchi yoki funksiya deyiladi.

Siz  $y = kx + b$  chiziqli funksiya va  $y = ax^2 + bx + c$  kvadrat funksiya bilan tanishsiz.

Bu funksiyalar uchun argumentning qiymati istalgan haqiqiy son bo'lishi mumkin.

Endi har bir nomanfiy  $x$  songa  $\sqrt{x}$  sonni mos qo'yadigan funksiyaning, ya'ni  $y = \sqrt{x}$  funksiyaning qaraymiz. Bu funksiya uchun argument faqat nomanfiy qiymatlarni qabul qilishi mumkin:  $x \geq 0$ . Bu holda funksiya barcha nomanfiy sonlar to'plamida aniqlangan deyiladi va bu to'plam  $y = \sqrt{x}$  funksiyaning *aniqlanish sohasi* deb ataladi.

Umuman, funksiyaning *aniqlanish sohasi* deb uning argumenti qabul qilinishi mumkin bo'lgan barcha qiymatlar to'plamiga aytiladi.

Masalan,  $y = \frac{1}{x}$  formula bilan berilgan funksiya  $x \neq 0$  da aniqlangan, ya'ni bu funksiyaning aniqlanish sohasi – noldan farqli barcha haqiqiy sonlar to'plami.

Agar funksiya formula bilan berilgan bo'lsa, u holda funksiya argumentning berilgan formula ma'noga ega bo'ladigan (ya'ni formulaning o'ng qismida turgan ifodada ko'rsatilgan hamma amallar bajariladigan) barcha qiymatlarida aniqlangan, deb hisoblash qabul qilingan.

Formula bilan berilgan funksiyaning aniqlanish sohasini topish – argumentning formula ma'noga ega bo'ladigan barcha qiymatlarini topish demakdir.

**1 - masala.** Funksiyaning aniqlanish sohasini toping:

1)  $y(x) = 2x^2 + 3x + 5$ ;      2)  $y(x) = \sqrt{x-1}$ ;

3)  $y(x) = \frac{1}{x+2}$ ;      4)  $y(x) = \sqrt[4]{\frac{x+2}{x-2}}$ .

$\triangle$  1)  $2x^2 + 3x + 5$  ifoda  $x$  ning istalgan qiymatida ma'noga ega bo'lgani uchun, funksiya barcha  $x$  larda aniqlangan.

**Javob:**  $x$  – istalgan son.

2)  $\sqrt{x-1}$  ifoda  $x-1 \geq 0$  bo'lganda ma'noga ega, ya'ni funksiya  $x \geq 1$  bo'lganda aniqlangan.

**Javob:**  $x \geq 1$ .

3)  $\frac{1}{x+2}$  ifoda  $x+2 \neq 0$  bo'lganda ma'noga ega, ya'ni funksiya  $x \neq -2$  bo'lganda aniqlangan.

**Javob:**  $x \neq -2$ .

4)  $\sqrt[4]{\frac{x+2}{x-2}}$  ifoda  $\frac{x+2}{x-2} \geq 0$  bo'lganda ma'noga ega. Bu tengsizlikni yechib, hosil qilamiz (28- rasm):  $x \leq -2$  va  $x > 2$ , ya'ni funksiya  $x \leq -2$  va  $x > 2$  bo'lganda aniqlangan.

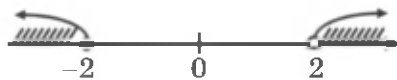

28- rasm.

**Javob:**  $x \leq -2, x > 2$ .  $\blacktriangle$

*Funksiyaning grafigi* deb koordinatalar tekisligining absissalari shu funksiyaning aniqlanish sohasidan olingan erkli o'zgaruvchining qiymatlariga, ordinatalari esa funksiyaning mos qiymatlariga teng bo'lgan nuqtalar to'plamiga aytilishini eslatib o'tamiz.

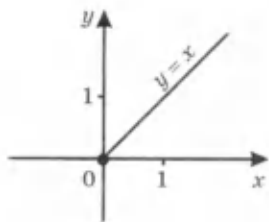

29- rasm.

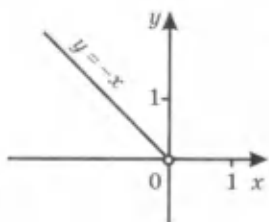

30- rasm.

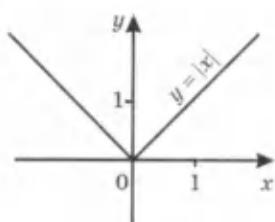

31- rasm.

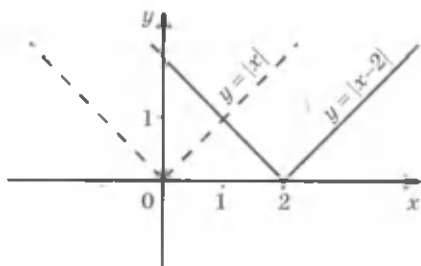

32- rasm.

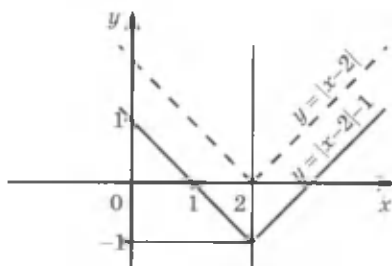

33- rasm.

**2-masala.**  $y = |x|$  funksiyaning aniqlanish sohasini toping va uning grafigini yasang.

△ Eslatib o'tamiz:

$$|x| = \begin{cases} x, & \text{agar } x \geq 0 \text{ bo'lsa,} \\ -x, & \text{agar } x < 0 \text{ bo'lsa.} \end{cases}$$

Shunday qilib,  $|x|$  ifoda istalgan haqiqiy  $x$  da ma'noga ega, ya'ni  $y = |x|$  funksiyaning aniqlanish sohasi barcha haqiqiy sonlar to'plamidan iborat.

Agar  $x \geq 0$  bo'lsa, u holda  $|x| = x$  bo'ladi va, shuning uchun,  $x \geq 0$  bo'lganda  $y = |x|$  funksiyaning grafigi birinchi koordinata burchagining bissektrisasi bo'ladi (29- rasm).

Agar  $x < 0$  bo'lsa, u holda  $|x| = -x$  bo'ladi, demak, manfiy  $x$  lar uchun  $y = |x|$  funksiyaning grafigi 31- rasmda tasvirlangan. ▲ irchagining bissektrisasi bo'ladi (30- rasm).

$y = |x|$  funksiyaning grafigi 31- rasmda tasvirlangan. ▲

Istalgan  $x$  uchun  $|-x| = |x|$ . Shuning uchun  $y = |x|$  funksiyaning grafigi ordinatalar o'qiga nisbatan simmetrik joylashgan.

**3-masala.**  $y = |x - 2| - 1$  funksiyaning grafigini yasang.

$\triangle$   $y = |x - 2|$  funksiyaning grafigi  $y = |x|$  funksiya grafigidan uni  $Ox$  o'q bo'yicha 2 birlik o'ngga surish bilan hosil qilinadi (32- rasm).

$y = |x - 2| - 1$  funksiyaning grafigini hosil qilish uchun  $y = |x - 2|$  funksiyaning grafigini bir birlik pastga surish yetarli (33- rasm).  $\blacktriangle$

### Mashqlar

**191.** Funksiya  $y(x) = x^2 - 4x + 5$  formula bilan berilgan:

1)  $y(-3)$ ,  $y(-1)$ ,  $y(0)$ ,  $y(2)$  ni toping;

2) agar  $y(x) = 1$ ,  $y(x) = 5$ ,  $y(x) = 10$ ,  $y(x) = 17$  bo'lsa,  $x$  ning qiymatini toping.

**192.** Funksiya  $y(x) = \frac{x+5}{x-1}$  formula bilan berilgan:

1)  $y(-2)$ ,  $y(0)$ ,  $y(\frac{1}{2})$ ,  $y(3)$  ni toping;

2) agar  $y(x) = -3$ ,  $y(x) = -2$ ,  $y(x) = 13$ ,  $y(x) = 19$  bo'lsa,  $x$  ning qiymatini toping.

Funksiyaning aniqlanish sohasini toping (193–194):

**193.** (Og'zaki).

1)  $y = 4x^2 - 5x + 1$ ;

2)  $y = 2 - x - 3x^2$ ;

3)  $y = \frac{2x-3}{x-3}$ ;

4)  $y = \frac{3}{5-x^2}$ ;

5)  $y = \sqrt[4]{6-x}$ ;

6)  $y = \sqrt{\frac{1}{x+7}}$ .

**194.** 1)  $y = \frac{2x}{x^2-2x-3}$ ;

2)  $y = \sqrt[6]{x^2-7x+10}$ ;

3)  $y = \sqrt[3]{3x^2-2x+5}$ ;

4)  $y = \sqrt[6]{\frac{2x+4}{3-x}}$ .

---

**195.** Funksiya  $y(x) = |2-x| - 2$  formula bilan berilgan:

1)  $y(-3)$ ,  $y(-1)$ ,  $y(1)$ ,  $y(3)$  ni toping;

2) agar  $y(x) = -2$ ,  $y(x) = 0$ ,  $y(x) = 2$ ,  $y(x) = 4$  bo'lsa,  $x$  ning qiymatini toping.

196. Funksiyaning aniqlanish sohasini toping:

$$1) y = \sqrt{\frac{x-2}{x+3}};$$

$$2) y = \sqrt[3]{\frac{1-x}{1+x}};$$

$$3) y = \sqrt[4]{(x-1)(x-2)(x-3)}; \quad 4) y = \sqrt{\frac{x^2-4}{x+1}};$$

$$5) y = \sqrt{(x+1)(x-1)(x-4)}; \quad 6) y = \sqrt[8]{\frac{x^2+4x-5}{x-2}};$$

$$7) y = \sqrt[4]{-x} + \sqrt{x+2};$$

$$8) y = \sqrt[6]{x} + \sqrt{1+x}.$$

197.  $(-2; 1)$  nuqta funksiya grafigiga tegishli bo'ladimi:

$$1) y = 3x^2 + 2x + 29;$$

$$2) y = |4 - 3x| - 9;$$

$$3) y = \frac{x^2+3}{x-1};$$

$$4) y = \sqrt{2-x} - 5| - 2?$$

198. Funksiya grafigini yasang:

$$1) y = |x+3| + 2;$$

$$2) y = -|x|;$$

$$3) y = 2|x| + 1;$$

$$4) y = 1 - |1 - 2x|;$$

$$5) y = |x| + |x - 2|;$$

$$6) y = |x+1| - |x|.$$

199.  $y = ax^2 + bx + c$  funksiya  $A(0; 1)$ ,  $B(1; 2)$ ,  $C(\frac{5}{6}; 1)$  nuqtalardan o'tadi. 1)  $a$ ,  $b$ ,  $c$  ni toping; 2)  $x$  ning qanday qiymatlarida  $y = 0$  bo'ladi? 3) funksiya grafigini chizing.

## 15- §.

## FUNKSIYANING O'SISHI VA KAMAYISHI

Siz  $y = x$  va  $y = x^2$  funksiyalar bilan tanishsiz. Bu funksiyalar darajali funksiyaning, ya'ni

$$y = x^r \tag{1}$$

(bunda  $r$  - berilgan son) funksiyaning xususiy hollaridir.

$r$  - natural son bo'lsin,  $r = n = 1, 2, 3, \dots$  deylik. Bu holda natural ko'rsatkichli darajali funksiya  $y = x^n$  ni hosil qilamiz.

Bu funksiya barcha haqiqiy sonlar to'plamida, ya'ni son o'qining hamma yerida aniqlangan. Odatda, barcha haqiqiy sonlar to'plami  $\mathbf{R}$  harfi bilan belgilanadi. Shunday qilib, natural ko'rsatkichli darajali funksiya  $y = x^n$ ,  $x \in \mathbf{R}$  uchun aniqlangan. Agar (1) da  $r = -2k$ ,  $k \in \mathbf{N}$  bo'lsa, u holda  $y = x^{-2k} = \frac{1}{x^{2k}}$  funksiya hosil bo'ladi. Bu funksiya  $x$  ning nol-dan farqli barcha qiymatlarida aniqlangan. Uning grafigi  $Oy$  o'qqa nisbatan simmetrik.  $r = -(2k-1)$ ,  $k \in \mathbf{N}$  bo'lsa, u holda  $y = x^{-(2k-1)} = \frac{1}{x^{2k-1}}$



funksiyani olamiz. Uning xossalari sizga tanish  $y = \frac{1}{x}$  funksiyaning xossalari kabi bo'ladi.  $p$  va  $q$  - natural sonlar va  $r = \frac{p}{q}$  - qisqarmas kasr bo'lsin.  $y = \sqrt[q]{x^p}$  funksiyaning aniqlanish sohasi  $p$  va  $q$  ning juft-toqligiga qarab turlicha bo'ladi. Masalan,  $y = \sqrt{x^2}$ ,  $y = \sqrt[3]{x}$  funksiyalar ixtiyoriy  $x \in \mathbf{R}$  da aniqlangan.  $y = \sqrt{x^3}$  funksiya esa  $x$  ning nomanfiy, ya'ni  $x \geq 0$  qiymatlarida aniqlangan.

8-sinf «Algebra» kursidan ma'lumki, har bir irratsional sonni chekli o'nli kasr bilan, ya'ni ratsional son bilan yaqinlashtirish mumkin. Amaliyotda irratsional sonlar ustida amallar ularning ratsional yaqinlashishlari yordamida bajariladi. Bu amallar shunday kiritiladiki, amallarning, tenglik va tengsizliklarning ratsional sonlar uchun xossalari irratsional sonlar uchun ham to'la saqlanadi.

$r_1, r_2, \dots, r_h, \dots$  ratsional sonlar  $r$  irratsional sonning ratsional yaqinlashishlari bo'lsin. U holda  $x$  musbat son bo'lganda,  $x$  ning ratsional darajalari, ya'ni  $x^{r_1}, x^{r_2}, \dots, x^{r_h}, \dots$  sonlar  $x^r$  darajaning yaqinlashishlari bo'ladi. Bunday aniqlangan daraja *irratsional ko'rsatkichli daraja* deyiladi. Demak,  $x > 0$  uchun daraja ko'rsatkichi ixtiyoriy  $r$  bo'lgan  $y = x^r$  funksiyani aniqlash mumkin.

Darajali funksiya  $x$  ning (1) formula ma'noga ega bo'ladigan qiymatlari uchun aniqlangan. Masalan,  $y = x$  va  $y = x^2$  ( $r = 1$  va  $r = 2$ ) funksiyalarning aniqlanish sohasi barcha haqiqiy sonlar to'plami bo'ladi;  $y = \frac{1}{x}$  ( $r = -1$ ) funksiyaning aniqlanish sohasi nolga teng bo'lmagan barcha haqiqiy sonlar to'plami bo'ladi;  $y = \sqrt{x}$  ( $r = \frac{1}{2}$ ) funksiyaning aniqlanish sohasi barcha nomanfiy sonlar to'plamidan iborat.

**Shuni eslatamizki, agar argumentning biror oraliqdan olingan katta qiymatiga funksiyaning katta qiymati mos kelsa, ya'ni shu oraliqqa tegishli istalgan  $x_1, x_2$  uchun  $x_2 > x_1$ , tengsizlikdan  $y(x_2) > y(x_1)$  tengsizlik kelib chiqsa,  $y(x)$  funksiya shu oraliqda *o'suvchi* funksiya deyiladi.**

**Agar biror oraliqqa tegishli istalgan  $x_1, x_2$  uchun  $x_2 > x_1$ , tengsizlikdan  $y(x_2) < y(x_1)$  kelib chiqsa,  $y(x)$  funksiya shu oraliqda *kamayuvchi* funksiya deyiladi.**

Masalan,  $y = x$  funksiya sonlar o'qida o'sadi.  $y = x^2$  funksiya  $x \geq 0$  oraliqda o'sadi,  $x \leq 0$  oraliqda kamayadi.

$y = x^r$  darajali funksiyaning o'sishi yoki kamayishi daraja ko'rsatkichining ishorasiga bog'liq.



Agar  $r > 0$  bo'lsa, u holda  $y = x^r$  darajali funksiya  $x \geq 0$  oraliqda o'sadi.

○  $x_2 > x_1 \geq 0$  bo'lsin.  $x_2 > x_1$  tengsizlikni musbat  $r$  darajaga ko'tarib,  $x_2^r > x_1^r$  ni, ya'ni  $y(x_2) > y(x_1)$  ni hosil qilamiz. ●

Masalan,  $y = \sqrt{x}$  va  $y = x^{\frac{3}{2}}$  funksiyalar  $x \geq 0$  oraliqda o'sadi. Bu funksiyalarning grafiklari 34- rasmda tasvirlangan. Shu rasmdan  $y = \sqrt{x}$  funksiyaning grafigi  $0 < x < 1$  oraliqda  $y = x$  funksiyaning grafigidan yuqorida,  $x > 1$  oraliqda esa  $y = x$  funksiyaning grafigidan pastda yotishi ko'rinib turibdi.

Agar  $0 < r < 1$  bo'lsa,  $y = x^r$  funksiyaning grafigi xuddi shunday xossaga ega bo'ladi.

$y = x^{\frac{3}{2}}$  funksiyaning grafigi  $0 < x < 1$  oraliqda  $y = x$  funksiya grafigidan pastda,  $x > 1$  oraliqda esa  $y = x$  funksiya grafigidan yuqorida yotadi.

$r > 1$  bo'lsa,  $y = x^r$  funksiyaning grafigi xuddi shunday xossaga ega bo'ladi.

Endi  $r < 0$  bo'lgan holni qaraymiz.

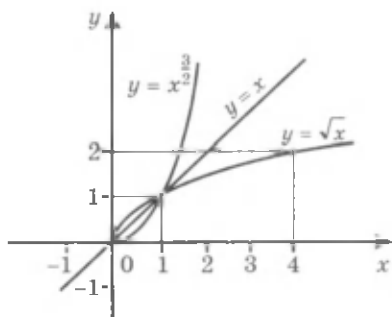

34- rasm.

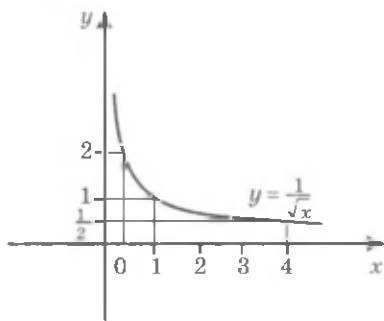

35- rasm.



Agar  $r < 0$  bo'lsa, u holda  $y = x^r$  darajali funksiya  $x > 0$  oraliqda kamayadi.

○  $x_2 > x_1 > 0$  bo'lsin.  $x_2 > x_1$  tengsizlikni manfiy  $r$  darajaga ko'tarib, chap va o'ng qismlari musbat bo'lgan tengsizliklarning xossasiga ko'ra  $x_2^r < x_1^r$  ni, ya'ni  $y(x_2) < y(x_1)$  ni hosil qilamiz. ●

Masalan,  $y = \frac{1}{\sqrt{x}}$ , ya'ni  $y = x^{-\frac{1}{2}}$  funksiya  $x > 0$  oraliqda kamayadi. Bu funksiyaning grafigi 35- rasmda tasvirlangan.

**1- masala.**  $x^{\frac{3}{4}} = 27$  tenglamani yeching.

△  $y = x^{\frac{3}{4}}$  funksiya  $x \geq 0$  da aniqlangan. Shuning uchun berilgan tenglama faqat nomanfiy ildizlarga ega bo'lishi mumkin. Bunday ildizlardan biri:  $x = 27^{\frac{4}{3}} = (\sqrt[3]{27})^4 = 3^4 = 81$ . Tenglamaning boshqa ildizlari yo'q, chunki  $y = x^{\frac{3}{4}}$  funksiya  $x \geq 0$  bo'lganda o'sadi va shuning uchun, agar  $x > 81$  bo'lsa, u holda  $x^{\frac{3}{4}} > 27$ , agar  $x < 81$  bo'lsa, u holda  $x^{\frac{3}{4}} < 27$  bo'ladi (36- rasm). ▲

$x^r = b$  (bunda  $r \neq 0$ ,  $b > 0$ ) tenglamaning har doim musbat  $x = b^{\frac{1}{r}}$  ildizga egaligi, shu bilan birga bu ildizning yagonaligi shunga o'xshash isbotlanadi. Demak,  $y = x^r$  (bunda  $r > 0$ ) funksiya  $x > 0$  bo'lganda barcha musbat qiymatlarni qabul qiladi.

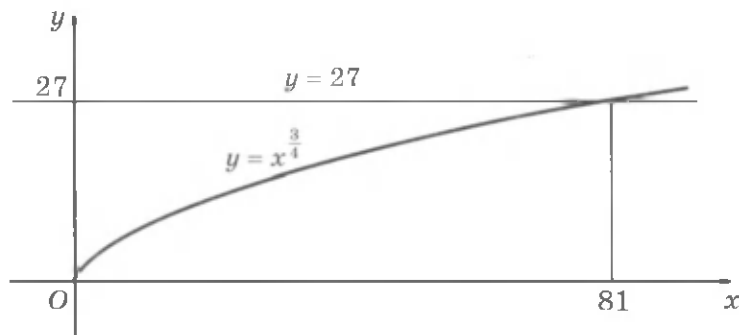

36- rasm.

Bu esa, masalan,  $y = x^{\frac{3}{4}}$  (36-rasm) funksiyaning sekinlik bilan o'sishiga qaramasdan, uning grafigi  $Ox$  o'qdan istalgancha uzoqlasishini va  $y = b$  to'g'ri chiziqni,  $b$  ning qanday musbat son bo'lishiga qaramasdan, kesishini bildiradi.

**2-masala.**  $y = x + \frac{1}{x}$  funksiyaning  $x > 1$  oraliqda o'sishini isbotlang.

$\Delta x_2 > x_1 > 1$  bo'lsin.  $y(x_2) > y(x_1)$  ekanligini ko'rsatamiz.  $y(x_2) - y(x_1)$  ayirmani qaraymiz:

$$y(x_2) - y(x_1) = x_2 + \frac{1}{x_2} - (x_1 + \frac{1}{x_1}) = (x_2 - x_1) \frac{x_1 x_2 - 1}{x_1 x_2}.$$

$x_2 > x_1$ ,  $x_1 > 1$ ,  $x_2 > 1$  bo'lgani uchun  $x_2 - x_1 > 0$ ,  $x_1 x_2 > 1$ ,  $x_1 x_2 > 0$ . Shuning uchun  $y(x_2) - y(x_1) > 0$ , ya'ni  $y(x_2) > y(x_1)$ .  $\blacktriangle$

### *Mashqlar*

**200.** Funksiyaning grafigini yasang hamda o'sish va kamayish oraliqlarini toping:

1)  $y = 2x + 3$ ;    2)  $y = 1 - 3x$ ;    3)  $y = x^2 + 2$ ;  
 4)  $y = 3 - x^2$ ;    5)  $y = (1 - x)^2$ ;    6)  $y = (2 + x)^2$ .

**201.** (Og'zaki). Funksiya  $x > 0$  oraliqda o'sadimi yoki kamayadimi:

1)  $y = x^{\frac{3}{7}}$ ;    2)  $y = x^{-\frac{3}{4}}$ ;    3)  $y = x^{-\sqrt{2}}$ ;    4)  $y = x^{\sqrt{3}}$ ?

**202.**  $x > 0$  bo'lganda:

1)  $y = x^{\frac{3}{2}}$ ;    2)  $y = x^{\frac{2}{3}}$ ;    3)  $y = x^{-\frac{3}{2}}$ ;    4)  $y = x^{-\frac{2}{3}}$

funksiya grafigi eskizini chizing.

**203.** Tenglamaning musbat ildizini toping:

1)  $x^{\frac{1}{2}} = 3$ ;    2)  $x^{\frac{1}{4}} = 2$ ;    3)  $x^{-\frac{1}{2}} = 3$ ;  
 4)  $x^{-\frac{1}{4}} = 2$ ;    5)  $x^{\frac{5}{6}} = 32$ ;    6)  $x^{-\frac{4}{5}} = 81$ .

204. Millimetrli qog'ozga  $y = \sqrt[4]{x}$  funksiyaning grafigini chizing. Grafik bo'yicha:

- 1)  $y = 0,5; 1; 4; 2,5$  bo'lganda  $x$  ning qiymatlarini toping;
- 2)  $\sqrt[4]{1,5}; \sqrt[4]{2}; \sqrt[4]{2,5}; \sqrt[4]{3}$  qiymatlarni taqriban toping.

---

205. Funksiyalar grafiglari kesishish nuqtalarining koordinatalarini toping:

- 1)  $y = x^{\frac{4}{3}}$  va  $y = 625$ ;      2)  $y = x^{\frac{6}{5}}$  va  $y = 64$ ;
- 3)  $y = x^{\frac{3}{2}}$  va  $y = 216$ ;      4)  $y = x^{\frac{7}{3}}$  va  $y = 128$ .

206. 1)  $y = x + \frac{1}{x}$  funksiyaning  $0 < x < 1$  oraliqda kamayishini isbotlang;

2)  $y = \frac{1}{x^2+1}$  funksiyaning  $x \geq 0$  oraliqda kamayishini va  $x \leq 0$  oraliqda o'sishini isbotlang;

3)  $y = x^3 - 3x$  funksiyaning  $x \leq -1$  va  $x \geq 1$  oraliqlarda o'sishini va  $-1 \leq x \leq 1$  kesmada kamayishini isbotlang;

4)  $y = x - 2\sqrt{x}$  funksiyaning  $x \geq 1$  oraliqda o'sishini va  $0 \leq x \leq 1$  kesmada kamayishini isbotlang.

207. Funksiya grafigini yasang hamda o'sish va kamayish oraliqlarini toping:

1)  $y = \begin{cases} x + 2, & \text{agar } x \leq -1 \text{ bo'lsa,} \\ x^2, & \text{agar } x > -1 \text{ bo'lsa;} \end{cases}$

2)  $y = \begin{cases} x^2, & \text{agar } x \leq 1 \text{ bo'lsa,} \\ 2 - x^2, & \text{agar } x > 1 \text{ bo'lsa.} \end{cases}$

---

## 16- §.

## FUNKSIYANING JUFTLIGI VA TOQLIGI

Siz  $y = x^2$  va  $y = |x|$  funksiyalarning grafiglari ordinatalar o'qiga nisbatan simmetrik (37 va 38- rasmlar) ekanligini bilasiz. Bunday funksiyalar *juft funksiyalar* deyiladi.

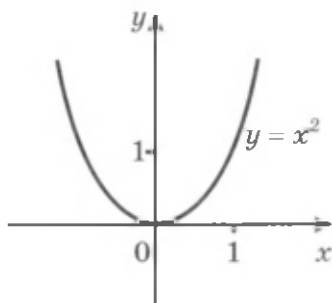

37- rasm.

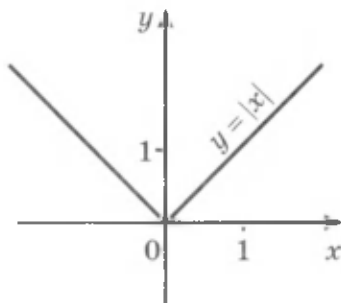

38- rasm.

Agar  $y(x)$  funksiyaning aniqlanish sohasidan olingan istalgan  $x$  uchun  $y(-x) = y(x)$  bo'lsa, bu funksiya *juft funksiya* deyiladi.



Masalan,  $y = x^4$  va  $y = \frac{1}{x^2}$  funksiyalar juft funksiyalar, chunki istalgan  $x$  uchun  $(-x)^4 = x^4$  va istalgan  $x \neq 0$  uchun  $\frac{1}{(-x)^2} = \frac{1}{x^2}$ .

**1-masala.**  $y = x^3$  funksiyaning grafigi koordinatalar boshiga nisbatan simmetrik ekanligini isbotlang va grafigini yasang.

△ 1)  $y = x^3$  funksiyaning aniqlanish sohasi – barcha haqiqiy sonlar to'plami.

2)  $y = x^3$  funksiyaning qiymatlari  $x > 0$  bo'lganda musbat,  $x < 0$  bo'lganda manfiy,  $x = 0$  bo'lganda nolga teng.

○ Aytaylik,  $(x_0; y_0)$  nuqta  $y = x^3$  funksiyaning grafigiga tegishli, ya'ni  $y_0 = x_0^3$  bo'lsin.  $(x_0; y_0)$  nuqtaga koordinatalar boshiga nisbatan simmetrik bo'lgan nuqta  $(-x_0; -y_0)$  koordinatalarga ega bo'ladi. Bu nuqta ham  $y = x^3$  funksiyaning grafigiga tegishli bo'ladi, chunki  $y_0 = x_0^3$  to'g'ri tenglikning ikkala qismini  $-1$  ga ko'paytirib, hosil qilamiz:  $-y_0 = -x_0^3$  yoki  $-y_0 = (-x_0)^3$ . ●

Bu xossa  $y = x^3$  funksiyaning grafigini yasashga imkon beradi: avval grafik  $x \geq 0$  uchun yasaladi, so'ngra esa uni koordinatalar boshiga nisbatan simmetrik akslantiriladi.

3)  $y = x^3$  funksiya aniqlanish sohasining hamma yerida o'sadi. Bu musbat ko'rsatkichli darajali funksiyaning  $x \geq 0$  bo'lganda o'sish xossa-

sidan va grafikning koordinatalar boshiga nisbatan simmetrikligidan kelib chiqadi.

4)  $x \geq 0$  ning ba'zi qiymatlari (masalan,  $x = 0, 1, 2, 3$ ) uchun  $y = x^3$  funksiyaning qiymatlari jadvalini tuzamiz,  $x \geq 0$  bo'lganda grafikning bir qismini yasaymiz va so'ngra simmetriya yordamida grafikning  $x$  ning manfiy qiymatlariga mos keluvchi qismini yasaymiz (39- rasm). ▲

Grafiklari koordinatalar boshiga nisbatan simmetrik bo'lgan funksiyalar toq funksiyalar deyiladi. Shunday qilib,  $y = x^3$  - toq funksiya.

**Agar  $y(x)$  funksiyaning aniqlanish sohasidan olingan istalgan  $x$  uchun**

$$y(-x) = -y(x)$$

**bo'lsa, bu funksiya toq funksiya deyiladi.**



Masalan,  $y = x^5$ ,  $y = \frac{1}{x^3}$  funksiyalar toq funksiyalardir, chunki istalgan  $x$  uchun  $(-x)^5 = -x^5$  va istalgan  $x \neq 0$  uchun  $\frac{1}{(-x)^3} = -\frac{1}{x^3}$ .

Juft va toq funksiyalarning aniqlanish sohasi koordinatalar boshiga nisbatan simmetrik ekanligini ta'kidlab o'tamiz.

Juftlik yoki toqlik xossalariga ega bo'lmagan funksiyalar mavjud. Masalan,  $y = 2x + 1$  funksiyaning juft ham, toq ham emasligini ko'rsatamiz. Agar bu funksiya juft bo'lganida edi, u holda barcha  $x$  uchun  $2(-x) + 1 = 2x + 1$  tenglik bajarilgan bo'lar edi; lekin, masalan,  $x = 1$  bo'lganda bu tenglik noto'g'ri:  $-1 \neq 3$ . Agar bu funksiya toq bo'lganida edi, u holda barcha  $x$  uchun  $2(-x) + 1 = -(2x + 1)$  tenglik bajarilgan bo'lar edi; lekin masalan,  $x = 2$  bo'lganda bu tenglik noto'g'ri:  $-3 \neq -5$ .

**2-masala.**  $y = \sqrt[3]{x}$  funksiyaning grafi-gini yasang.

△ 1) Aniqlanish sohasi - barcha haqiqiy sonlar.

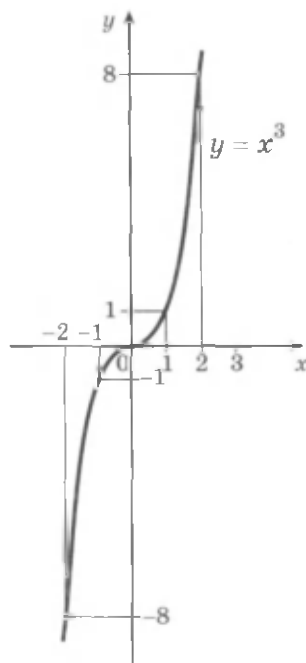

39- rasm.

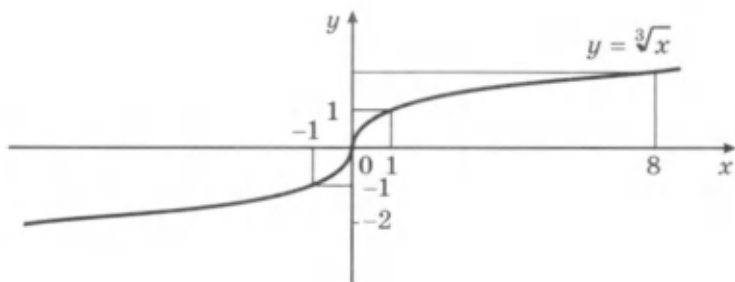

40- rasm.

2) funksiya – toq, chunki istalgan  $x$  uchun  $\sqrt[3]{-x} = -\sqrt[3]{x}$ .

3)  $x \geq 0$  bo'lganda funksiya musbat ko'rsatkichli darajali funksiya-ning xossasiga ko'ra o'sadi, chunki  $x \geq 0$  bo'lganda  $\sqrt[3]{x} = x^{\frac{1}{3}}$ .

4)  $x > 0$  bo'lganda funksiyaning qiymati musbat;  $y(0) = 0$ .

5) grafikka tegishli bir nechta, masalan,  $(0; 0)$ ,  $(1; 1)$ ,  $(8; 2)$  nuqtalarni topib,  $x \geq 0$  ning qiymatlari uchun grafikning bir qismini yasaymiz va so'ngra simmetriya yordamida  $x < 0$  uchun grafikning ikkinchi qismini yasaymiz (40- rasm). ▲

$y = \sqrt[3]{x}$  funksiya barcha  $x$  lar uchun,  $y = x^{\frac{1}{3}}$  funksiya esa faqat  $x \geq 0$  uchun aniqlanganligini ta'kidlab o'tamiz.

### Mashqlar

Funksiya toq yoki juft bo'lishini aniqlang (208–209):

208. 1)  $y = 2x^4$ ; 2)  $y = 3x^5$ ; 3)  $y = x^2 + 3$ ; 4)  $y = x^3 - 2$ .

209. 1)  $y = x^{-4}$ ; 2)  $y = x^{-3}$ ; 3)  $y = x^4 + x^2$ ;

4)  $y = x^3 + x^6$ ; 5)  $y = x^2 - x + 1$ ; 6)  $y = \frac{1}{x+1}$ .

210. Funksiya grafigining eskizini chizing:

1)  $y = x^4$ ; 2)  $y = x^5$ ; 3)  $y = -x^2 + 3$ ; 4)  $y = \sqrt[5]{x}$ .

211. Funksiya juft ham, toq ham emasligini ko'rsating:

1)  $y = \frac{x+2}{x-3}$ ; 2)  $y = \frac{x^2+x-1}{x+4}$ .



**212.** Funksiyaning juft yoki toq bo'lishini aniqlang:

1)  $y = x^4 + 2x^2 + 3$ ;    2)  $y = x^3 + 2x + 1$ ;    3)  $y = \frac{3}{x^3} + \sqrt[3]{x}$ ;

4)  $y = x^4 + |x|$ ;    5)  $y = |x| + x^3$ ;    6)  $y = \sqrt[3]{x-1}$ .

**213.** Simmetriyadan foydalanib, juft funksiyaning grafigini yasang:

1)  $y = x^2 - 2|x| + 1$ ;    2)  $y = x^2 - 2|x|$ .

**214.** Simmetriyadan foydalanib, toq funksiyaning grafigini yasang:

1)  $y = x|x| - 2x$ ;    2)  $y = x|x| + 2x$ .

**215.** Funksiyaning xossalarini aniqlang va uning grafigini yasang:

1)  $y = \sqrt{x-5}$ ;    2)  $y = \sqrt{x} + 3$ ;    3)  $y = x^4 + 2$ ;

4)  $y = 1 - x^4$ ;    5)  $y = (x+1)^3$ ;    6)  $y = x^3 - 2$ .

**216.** Funksiyaning grafigini yasang:

1)  $y = \begin{cases} x^2, & \text{agar } x \geq 0 \text{ bo'lsa,} \\ x^3, & \text{agar } x < 0 \text{ bo'lsa;} \end{cases}$

2)  $y = \begin{cases} x^3, & \text{agar } x > 0 \text{ bo'lsa,} \\ x^2, & \text{agar } x \leq 0 \text{ bo'lsa.} \end{cases}$

Argumentning qanday qiymatlarida funksiyaning qiymatlari musbat bo'lishini aniqlang. O'sish va kamayish oraliqlarini ko'rsating.

**217.**  $y$  funksiya berilgan:

1)  $y = x$ ;    2)  $y = x^2$ ;    3)  $y = x^2 + x$ ;    4)  $y = x^2 - x$ .

$x > 0$  bo'lganda  $y$  funksiyaning grafigini yasang.  $x < 0$  uchun shu funksiyalardan har birining grafigini shunday yasangki, yasalgan grafik: a) juft funksiyaning; b) toq funksiyaning grafigi bo'lsin. Hosil qilingan har bir funksiyaning bitta formula bilan bering.

**218.** Funksiya grafigi simmetriya o'qining tenglamasini yozing:

1)  $y = (x+1)^6$ ;    2)  $y = x^6 + 1$ .

**219.** Funksiya grafigi simmetriya markazining koordinatalarini ko'rsating:

1)  $y = x^3 + 1$ ;    2)  $y = (x+1)^3$ .

**1-masala.**  $y = \frac{1}{x}$  funksiyaning grafigini yasang.

△ 1) aniqlanish sohasi – noldan boshqa barcha haqiqiy sonlar.

2) funksiya – toq, chunki  $x \neq 0$  bo'lganda  $\frac{1}{-x} = -\frac{1}{x}$ .

3) funksiya  $x > 0$  oraliqda manfiy ko'rsatkichli darajali funksiyaning xossasiga ko'ra kamayadi, chunki  $\frac{1}{x} = x^{-1}$ .

4)  $x > 0$  bo'lganda funksiya musbat qiymatlarni qabul qiladi.

5) grafikka tegishli bir nechta, masalan,  $(\frac{1}{3}; 3)$ ,  $(\frac{1}{2}; 2)$ ,  $(1; 1)$ ,  $(2; \frac{1}{2})$  nuqtalarni topib,  $x > 0$  ning qiymatlari uchun grafikning bir qismini yasaymiz va so'ngra simmetriya yordamida  $x < 0$  uchun qolgan qismini yasaymiz (41- rasm). ▲

$y = \frac{1}{x}$  funksiyaning grafigi *giperbola* deyiladi. U *tarmoqlar* deb ataluvchi ikki qismdan tuzilgan. Tarmoqlardan biri birinchi chorakda, ikkinchisi esa uchinchi chorakda joylashgan.

**2-masala.**  $k = 2$  va  $k = -2$  bo'lganda  $y = \frac{k}{x}$  funksiyaning grafigini yasang.

△ Argumentning ayni bir xil qiymatlarida  $y = \frac{2}{x}$  funksiyaning qiymatlari  $y = \frac{1}{x}$  funksiya qiymatlarini 2 ga ko'paytirish bilan hosil

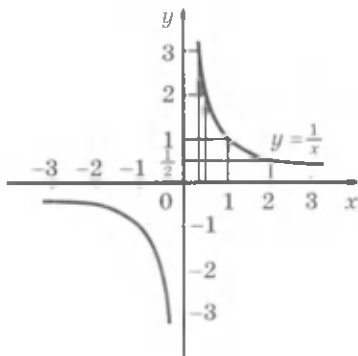

41- rasm.

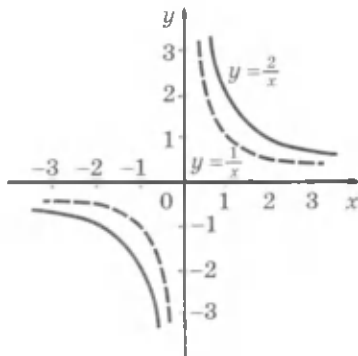

42- rasm.

qilinishini eslatamiz. Bu esa  $y = \frac{2}{x}$  funksiya-ning grafigi  $y = \frac{1}{x}$  funksiya grafigini absissalar o'qidan ordinatalar o'qi bo'ylab ikki baravar cho'zish bilan hosil qilinadi, demakdir (42- rasm).

$y = -\frac{2}{x}$  funksiyaning qiymatlari  $y = \frac{2}{x}$  funksiya qiymatlaridan faqat ishorasi bilan farq qiladi. Demak,  $y = -\frac{2}{x}$  funksiyaning grafigi  $y = \frac{2}{x}$  funksiya grafigiga absissalar o'qiga nisbatan simmetrik (43- rasm). ▲

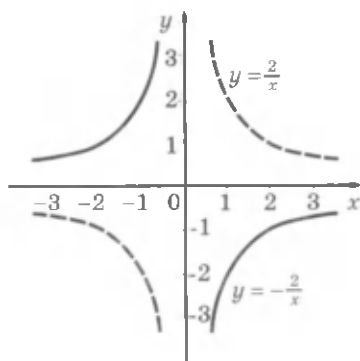

43- rasm.

Istalgan  $k \neq 0$  da  $y = \frac{k}{x}$  funksiyaning grafigi ham *giperbola* deyiladi. *Giperbola* ikkita tarmoqqa ega. Ular, agar  $k > 0$  bo'lsa, birinchi va uchinchi choraklarda, agar  $k < 0$  bo'lsa, ikkinchi va to'rtinchi choraklarda yotadi.

$y = \frac{k}{x}$  (bunda  $k > 0$ ) funksiya  $y = \frac{1}{x}$  funksiyaning barcha xossalari ega, chunonchi, bu funksiya:

- 1)  $x \neq 0$  bo'lganda aniqlangan;
- 2) noldan boshqa barcha haqiqiy qiymatlarni qabul qiladi;
- 3) toq;
- 4)  $x > 0$  bo'lganda *musbat* qiymatlarni va  $x < 0$  bo'lganda *manfiy* qiymatlarni qabul qiladi;
- 5)  $x < 0$  va  $x > 0$  oraliqlarda *kamayadi*.

Agar  $k < 0$  bo'lsa, u holda  $y = \frac{k}{x}$  funksiya 1–3-xossalarga ega bo'ladi; 4–5 xossalar esa bunday ifodalanadi:

- 4)  $x < 0$  bo'lganda *musbat* qiymatlarni va  $x > 0$  bo'lganda *manfiy* qiymatlarni qabul qiladi;
- 5)  $x < 0$  va  $x > 0$  oraliqlarda *o'sadi*.

$y = \frac{k}{x}$  funksiya  $k > 0$  bo'lganda  $x$  va  $y$  lar orasidagi *teskari proporsional bog'lanishni* ifoda qiladi, deyiladi. Miqdorlar orasidagi bunday bog'lanishlar ko'pincha fizika, texnika va boshqa sohalarda uchraydi.

Masalan,  $v$  o'zgarmas tezlik bilan aylana bo'ylab tekis harakat qilayotganda jism  $a = \frac{v^2}{r}$  ga teng (bu yerda  $r$  – aylana radiusi) markazga

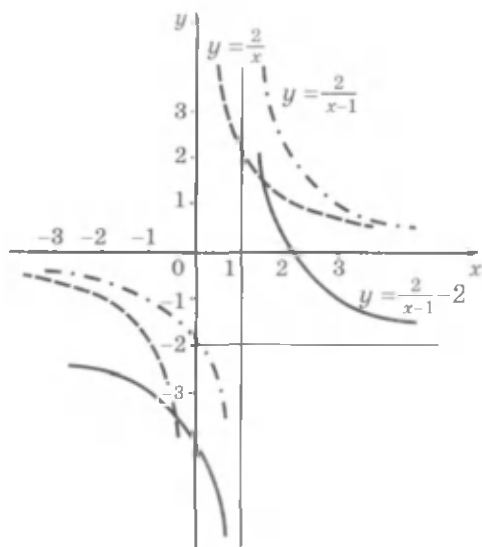

44- rasm.

**4- masala.**  $y = \frac{2}{x-1} - 2$  funksiya grafigini yasang.

△  $y = \frac{2}{x}$  funksiya grafigini (42- rasm)  $Ox$  o'q bo'ylab o'ngga bir birlik va  $Oy$  o'q bo'ylab ikki birlik pastga surish bilan  $y = \frac{2}{x-1} - 2$  funksiyaning grafigini hosil qilish mumkin (44- rasm). ▲

### Mashqlar

**220.**  $y = \frac{2}{x}$  funksiya grafigini yasang.  $x$  ning qanday qiymatlarida:

- 1)  $y(x) = 4$ ; 2)  $y(x) = -\frac{1}{2}$ ; 3)  $y(x) > 1$ ; 4)  $y(x) \leq 1$

bo'lishini aniqlang.

**221.** Bitta koordinatalar tekisligida  $y = \frac{1}{x}$  va  $y = x$  funksiyalar grafiglarini yasang.  $x$  ning qanday qiymatlarida:

- 1) bu funksiyalarning grafiglari kesishishini aniqlang;  
2) birinchi funksiyaning grafigi ikkinchi funksiya grafigidan yuqorida (pastda) yotishini aniqlang.

intilma tezlanish bilan harakatlanadi, ya'ni bu holda tezlanish aylana radiusiga teskari proporsional.

**3- masala.** Oy Yerdan  $3,84 \cdot 10^8$  m masofada. Oy 27,3 sutka davomida Yer atrofini bir marta aylanib chiqadi. Oyning markazga intilma tezlanishini hisoblang.

△  $a$  tezlanishni  $a = \frac{v^2}{r}$  formula bilan hisoblaymiz, bunda  $v = \frac{C}{t}$ ,  
 $C = 2\pi r$ ,  $t = 27,3 \cdot 24 \cdot 3600$  s,  
 $r = 3,84 \cdot 10^8$ . U holda:

$$a = \frac{4\pi^2 \cdot 3,84 \cdot 10^8}{(27,3 \cdot 24 \cdot 3600)^2} = 2,72 \cdot 10^{-3}.$$

**Javob:**  $2,72 \cdot 10^{-3}$  m/s<sup>2</sup>. ▲

222. Funksiyalarning grafiklarini yasamasdan, ularning kesishish nuqtalarini toping:
- 1)  $y = \frac{12}{x}$ ,  $y = 3x$ ;      2)  $y = -\frac{8}{x}$ ,  $y = -2x$ ;  
 3)  $y = \frac{2}{x}$ ,  $y = x - 1$ ;      4)  $y = \frac{6}{x+1}$ ,  $y = x + 2$ .
223. Funksiyalarning grafiklarini yasab, ularning kesishish nuqtalarini taqriban toping:
- 1)  $y = \frac{3}{x}$ ,  $y = x + 1$ ;      2)  $y = -\frac{3}{x}$ ,  $y = 1 - x$ ;  
 3)  $y = \frac{2}{x}$ ,  $y = x^2 + 2$ ;      4)  $y = \frac{1}{x}$ ,  $y = x^2 + 4x$ .
224. Silindrda porshen ostida gaz o'zgarmas haroratda turibdi. Gazning  $V$  (litrlarda) hajmi  $p$  (atmosfera) bosimida  $V = \frac{12}{p}$  formula bo'yicha hisoblanadi.
- 1) Bosim 4 atm; 5 atm; 10 atm bo'lganda gaz egallagan hajmni toping; 2) qanday bosimda gaz 3 l; 5 l; 15 l hajmni egallashini hisoblang; 3) gazning hajmi uning bosimiga bog'liqligi grafigini yasang.
225. Reostatdagi  $I$  tok kuchi (amperlarda)  $I = \frac{U}{R}$  formula bilan o'lchanadi, bunda  $U$  - kuchlanish (voltlarda),  $R$  - qarshilik (omlarda).
- 1)  $U = 6$  bo'lganda  $I(R)$  bog'lanishning grafigini yasang.  
 2) Grafik bo'yicha taqriban toping: a)  $R$  qarshilik 6, 12, 20 Om bo'lganda tok kuchini; b) tok kuchi 10, 5, 1,2 A bo'lganda reostatning qarshiligini.
226. Avtomobil yo'lning radiusi 150 m bo'lgan aylanma qismi bo'yicha 60 km/soat tezlik bilan harakat qilmoqda. Avtomobilning markazga intilma tezlanishini toping. Agar avtomobilning tezligi avvalgicha qolib, yo'lning aylanma qismi radiusi ortsa, markazga intilma tezlanish ortadimi yoki kamayadimi?
- 227.** Funksiyaning grafigini yasang:
- 1)  $y = \frac{3}{x} - 2$ ;    2)  $y = \frac{2}{x} + 1$ ;    3)  $y = \frac{2}{x+2} - 1$ ;    4)  $y = \frac{3}{1-x} + 1$ .

Darajali funksiyaning xossalaridan har xil tenglama va tengsizliklarni yechishda foydalaniladi.

**1-masala.**  $x^5 > 32$  tengsizlikni yeching.

$\triangle$   $y = x^5$  funksiya  $x$  ning barcha haqiqiy qiymatlarida aniqlangan va o'sadi.  $y(2) = 32$  bo'lgani uchun  $x > 2$  bo'lganda  $y(x) > 32$  va  $x < 2$  bo'lganda  $y(x) < 32$ .

**Javob:**  $x > 2$ . ▲

**2-masala.**  $x^4 \leq 81$  tengsizlikni yeching.

$\triangle$   $y = x^4$  funksiya  $x \leq 0$  bo'lganda kamayadi va  $x \geq 0$  bo'lganda o'sadi.  $x^4 = 81$  tenglama ikkita haqiqiy ildizga ega:  $x_1 = -3$ ,  $x_2 = 3$ . Shuning uchun  $x^4 \leq 81$  tengsizlik  $x \leq 0$  bo'lganda  $-3 \leq x \leq 0$  yechimlarga va  $x \geq 0$  bo'lganda  $0 \leq x \leq 3$  yechimlarga ega (45-rasm).

**Javob:**  $-3 \leq x \leq 3$ . ▲

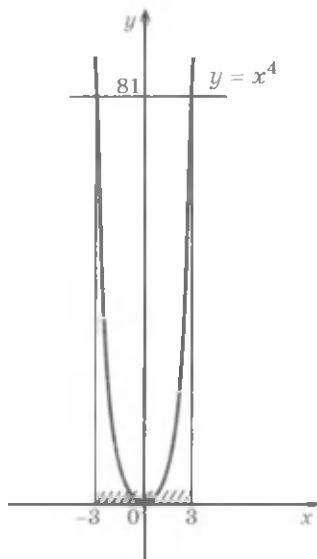

45-rasm.

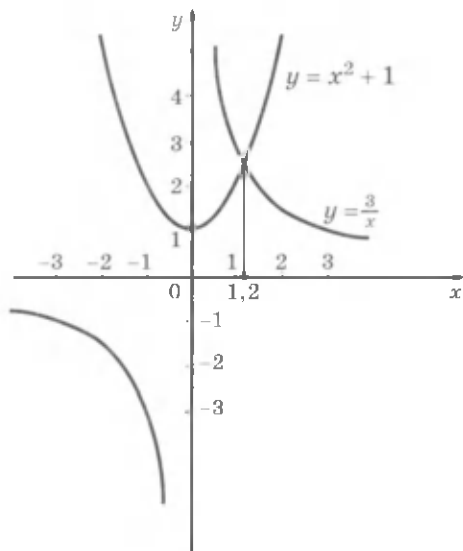

46-rasm.

**3-masala.** Funktsiyalarning grafiklari yordamida  $\frac{3}{x} = x^2 + 1$  tenglamani yeching.

Bitta koordinatalar tekisligida  $y = \frac{3}{x}$  va  $y = x^2 + 1$  funktsiyalarning grafiklarini yasaymiz (46- rasm).

$\triangle$   $x < 0$  bo'lganda  $\frac{3}{x} = x^2 + 1$  tenglama ildizlarga ega emas, chunki  $\frac{3}{x} < 0$ , lekin  $x^2 + 1 > 0$ .  $x > 0$  bo'lganda bu tenglama shu funktsiyalar kesishish nuqtasining absissasiga teng bo'lgan bitta ildizga ega. 46- rasmdan ko'rinib turibdiki,  $x_1 = 1,2$ . Tenglama boshqa musbat ildizlarga ega emas, chunki  $x > x_1$  bo'lganda  $y = \frac{3}{x}$  funktsiya kamayadi,  $y = x^2 + 1$  funktsiya esa o'sadi va demak, funktsiyalarning grafiklari  $x > x_1$  bo'lganda kesishmaydi. Xuddi shu sababga ko'ra ular  $0 < x < x_1$  bo'lganda ham kesishmaydi.

**Javob:**  $x_1 \approx 1,2$ .  $\blacktriangle$

**4-masala.**  $\sqrt{2-x^2} = x$  (1) tenglamani yeching.

$\triangle$  Aytaylik,  $x$  - berilgan tenglamaning ildizi bo'lsin, ya'ni  $x$  - shunday sonki, u (1) tenglamani to'g'ri tenglikka aylantiradi. Tenglamaning ikkala qismini kvadratga ko'tarib, hosil qilamiz:

$$2 - x^2 = x^2. \quad (2)$$

Bundan  $x^2 = 1$ ,  $x_{1,2} = \pm 1$ .

Demak, (1) tenglama ildizlarga ega, deb faraz qilib, biz bu ildizlar faqat 1 va  $-1$  sonlari bo'lishi mumkinligini bilib oldik, endi bu sonlar (1) tenglamaning ildizlari bo'lish yoki bo'lmasligini tekshiramiz.  $x = 1$  bo'lganda (1) tenglama to'g'ri tenglikka aylanadi:  $\sqrt{2-1^2} = 1$ . Shuning uchun  $x = 1$  (1) tenglamaning ildizi.

$x = -1$  bo'lganda (1) tenglamaning chap qismi  $\sqrt{2-(-1)^2} = \sqrt{1} = 1$  ga teng, o'ng qismi esa  $-1$  ga teng, ya'ni  $x = -1$  (1) tenglamaning ildizi bo'la olmaydi.

**Javob:**  $x = 1$ .  $\blacktriangle$

Qaralgan masalada (1) tenglama uning ikkala qismini kvadratga ko'tarish yo'li bilan yechiladi. Bunda (2) tenglama hosil bo'ldi.

(1) tenglama faqat bitta ildizga ega:  $x = 1$ , (2) tenglama esa ikkita ildizga ega:  $x_{1,2} = \pm 1$ , ya'ni (1) tenglamadan (2) tenglamaga o'tishda

*chet ildizlar* deb ataluvchi ildizlar paydo bo'ldi. Bu shuning uchun ham sodir bo'ldiki,  $x = -1$  bo'lganda (1) tenglama  $1 = -1$  dan iborat noto'g'ri tenglikka aylandi, bu noto'g'ri tenglikning ikkala qismini kvadratga ko'tarishda esa  $1^2 = (-1)^2$  dan iborat to'g'ri tenglik hosil bo'ldi.

**Shunday qilib, tenglamaning ikkala qismini kvadratga ko'tarishda chet ildizlar paydo bo'lishi mumkin.**

**Tenglamani uning ikkala qismini kvadratga ko'tarish bilan yechishda tekshirish o'tkazish zarur.**

(1) tenglama – *irratsional tenglamaga* misol.

Yana irratsional tenglamalarga misollar keltiramiz:

$$\sqrt{3-2x} = 1-x; \quad \sqrt{x+1} = 2-\sqrt{x-3}.$$

Bir nechta irratsional tenglamalarni yechishni qaraymiz.

**5-masala.**  $\sqrt{5-2x} = 1-x$  tenglamani yeching.

$\triangle$  Tenglamaning ikkala qismini kvadratga ko'taramiz:

$$5-2x = x^2 - 2x + 1$$

yoki  $x^2 = 4$ , bundan  $x_1 = 2$ ,  $x_2 = -2$ . Topilgan ildizlarni tekshiramiz.

$x = 2$  bo'lganda berilgan tenglamaning chap qismi  $\sqrt{5-2 \cdot 2} = 1$  ga teng, o'ng qismi  $1 - 2 = -1$  ga teng.  $1 \neq -1$  bo'lganligi uchun  $x = 2$  berilgan tenglamaning ildizi bo'la olmaydi.

$x = -2$  bo'lganda tenglamaning chap qismi  $\sqrt{5-2 \cdot (-2)} = 3$  ga teng, o'ng qismi  $1 - (-2) = 3$  ga teng. Demak,  $x = -2$  berilgan tenglamaning ildizi.

**J a v o b:**  $x = -2$ .  $\blacktriangle$

**6-masala.** Tenglamani yeching:  $\sqrt{x-2} + 3 = 0$ .

$\triangle$  Bu tenglamani  $\sqrt{x-2} = -3$  ko'rinishda yozib olaylik.

Arifmetik ildiz manfiy bo'lishi mumkin emas, binobarin, bu tenglama ildizlarga ega emas.

**J a v o b:** Ildizlari yo'q.  $\blacktriangle$



**7-masala.** Tenglamani yeching:  $\sqrt{x-1} + \sqrt{11-x} = 4$ .

$\triangle$  Tenglamaning ikkala qismini kvadratga ko'tarib, hosil qilamiz:

$$x-1 + 2\sqrt{x-1} \cdot \sqrt{11-x} + 11-x = 16.$$

O'xshash hadlarni ixchamlab, tenglamani bunday ko'rinishda yozamiz:

$$2\sqrt{x-1} \cdot \sqrt{11-x} = 6 \text{ yoki } \sqrt{x-1} \cdot \sqrt{11-x} = 3.$$

Oxirgi tenglamaning ikkala qismini kvadratga ko'taraylik:

$$(x-1)(11-x) = 9 \text{ yoki } x^2 - 12x + 20 = 0,$$

bundan  $x_1 = 2$ ,  $x_2 = 10$ . Tekshirish 2 va 10 sonlaridan har biri berilgan tenglamaning ildizi bo'lishini ko'rsatadi.

**Javob:**  $x_1 = 2$ ,  $x_2 = 10$ .  $\blacktriangle$

### Mashqlar

**228.** Tengsizlikni yeching:

1)  $x^7 > 1$ ;      2)  $x^3 \leq 27$ ;      3)  $y^3 \geq 64$ ;  
4)  $y^3 < 125$ ;      5)  $x^4 \leq 16$ ;      6)  $x^4 > 625$ .

**229.** 1) Agar kvadratning yuzi  $361 \text{ sm}^2$  dan katta ekanligi ma'lum bo'lsa, uning tomoni qanday bo'lishi mumkin?

2) Agar kubning hajmi  $343 \text{ dm}^3$  dan katta ekanligi ma'lum bo'lsa, uning qirrasini qanday bo'lishi mumkin?

**230.** (Og'zaki.) 7 soni tenglamaning ildizi bo'lishini ko'rsating:

1)  $\sqrt{x-3} = 2$ ;      2)  $\sqrt{x^2-13} - \sqrt{2x-5} = 3$ .

**231.** (Og'zaki.) Tenglamani yeching:

1)  $\sqrt{x} = 3$ ; 2)  $\sqrt{x} = 7$ ; 3)  $\sqrt{2x-1} = 0$ ; 4)  $\sqrt{3x+2} = 0$ .

Tenglamani yeching (**232–233**):

**232.** 1)  $\sqrt{x+1} = 2$ ;      2)  $\sqrt{x-1} = 3$ ;

3)  $\sqrt{1-2x} = 4$ ;      4)  $\sqrt{2x-1} = 3$ .

**233.** 1)  $\sqrt{x+1} = \sqrt{2x-3}$ ;      2)  $\sqrt{x-2} = \sqrt{3x-6}$ ;

3)  $\sqrt{x^2+24} = \sqrt{11x}$ ;      4)  $\sqrt{x^2+4x} = \sqrt{14-x}$ .

234. 1)  $\sqrt{x+2} = x$ ;                      2)  $\sqrt{3x+4} = x$ ;

3)  $\sqrt{20-x^2} = 2x$ ;                      4)  $\sqrt{0,4-x^2} = 3x$ .

235. 1)  $\sqrt{x^2-x-8} = x-2$ ;                      2)  $\sqrt{x^2+x-6} = x-1$ .

236. Tengsizlikni yeching:

1)  $(x-1)^3 > 1$ ;                      2)  $(x+5)^3 > 8$ ;                      3)  $(2x-3)^7 \geq 1$ ;

4)  $(3x-5)^7 < 1$ ;                      5)  $(3-x)^4 > 256$ ;                      6)  $(4-x)^4 > 81$ .

237. Berilgan tenglama nima uchun ildizlarga ega emasligini tushuntiring:

1)  $\sqrt{x} = -8$ ;                      2)  $\sqrt{x} + \sqrt{x-4} = -3$ ;

3)  $\sqrt{-2-x^2} = 12$ ;                      4)  $\sqrt{7x-x^2-63} = 5$ .

Tenglamani yeching (238–240):

238. 1)  $\sqrt{x^2-4x+9} = 2x-5$ ;                      2)  $\sqrt{x^2+3x+6} = 3x+8$ ;

3)  $2x = 1 + \sqrt{x^2+5}$ ;                      4)  $x + \sqrt{13-4x} = 4$ .

239. 1)  $\sqrt{x+12} = 2 + \sqrt{x}$ ;                      2)  $\sqrt{4+x} + \sqrt{x} = 4$ .

240. 1)  $\sqrt{2x+1} + \sqrt{3x+4} = 3$ ;                      2)  $\sqrt{4x-3} + \sqrt{5x+4} = 4$ ;

3)  $\sqrt{x-7} - \sqrt{x+17} = -4$ ;                      4)  $\sqrt{x+4} - \sqrt{x-1} = 1$ .

241.  $x$  ning qanday qiymatlarida funksiyalar bir xil qiymatlarni qabul qiladi:

1)  $y = \sqrt{4+\sqrt{x}}$ ,  $y = \sqrt{19-2\sqrt{x}}$ ;                      2)  $y = \sqrt{7+\sqrt{x}}$ ,  $y = \sqrt{11-\sqrt{x}}$ ?

242. Tengsizlikni yeching:

1)  $\sqrt{x-2} > 3$ ;                      2)  $\sqrt{x-2} \leq 1$ ;                      3)  $\sqrt{2-x} \geq x$ ;

4)  $\sqrt{2-x} < x$ ;                      5)  $\sqrt{5x+11} > x+3$ ;                      6)  $\sqrt{x+3} \leq x+1$ .

### *IV bobga doir mashqlar*

243. Funksiyaning aniqlanish sohasini toping:

1)  $y = \frac{1}{2x+1}$ ;                      2)  $y = (3-2x)^{-2}$ ;                      3)  $y = \sqrt{-5-3x}$ ;                      4)  $y = \sqrt[3]{7-3x}$ .

244. (Og'zaki.)  $y = \sqrt[4]{x}$  va  $y = x^5$  funksiyalarning o'sish yoki kamayish xossalaridan foydalanib, sonlarni taqqoslang:

- 1)  $\sqrt[4]{2,7}$  va  $\sqrt[4]{2,9}$ ;      2)  $\sqrt[4]{\frac{1}{7}}$  va  $\sqrt[4]{\frac{1}{8}}$ ;  
3)  $(-2)^5$  va  $(-3)^5$ ;      4)  $\left(2\frac{2}{3}\right)^5$  va  $\left(2\frac{3}{4}\right)^5$ .

245. Funksiyaning xossalarini aniqlang va uning grafigi eskizini chizing:

- 1)  $y = -2x^4$ ;    2)  $y = \frac{1}{2}x^5$ ;    3)  $y = 2\sqrt[4]{x}$ ;    4)  $y = 3\sqrt[3]{x}$ .

246. (Og'zaki.) Agar  $k = -4$ ,  $k = 3$  bo'lsa,  $y = \frac{k}{x}$  giperbolaning tarmoqlari qaysi choraklarda joylashgan?

247. Bitta chizmada  $y = x$  va  $y = x^3$  funksiyalarning grafiglarini yasang. Shu grafiglar kesishish nuqtasining koordinatalarini toping.

248. Funksiyalar grafiglari kesishish nuqtalarining koordinatalarini toping:

- 1)  $y = x^2$ ,  $y = x^3$ ;      2)  $y = \frac{1}{x}$ ,  $y = 2x$ ;  
3)  $y = \sqrt{x}$ ,  $y = |x|$ ;      4)  $y = \sqrt[3]{x}$ ,  $y = \frac{1}{x}$ .

249. Tengsizlikni yeching:

- 1)  $x^4 \leq 81$ ;    2)  $x^5 > 32$ ;    3)  $x^6 > 64$ ;    4)  $x^5 \leq -32$ .

250. Tenglamani yeching:

- 1)  $\sqrt{3-x} = 2$ ;      2)  $\sqrt{3x+1} = 7$ ;  
3)  $\sqrt{3-11x} = 2x$ ;    4)  $\sqrt{5x-1+3x^2} = 3x$ ;  
5)  $\sqrt{2x-1} = x-2$ ;    6)  $\sqrt{2-2x} = x+3$ .

---

251. Funksiyaning aniqlanish sohasini toping:

- 1)  $y = \sqrt{x^3 + x - 2}$ ;      2)  $y = \sqrt[3]{x^2 + 2x - 15}$ ;  
3)  $y = \sqrt{6 - x - x^2}$ ;      4)  $y = \sqrt[4]{13x - 22 - x^2}$ ;  
5)  $y = \sqrt{\frac{x^2+6x+5}{x+7}}$ ;      6)  $y = \sqrt{\frac{x^2-9}{x^2+8x+7}}$ .

### O'ZINGIZNI TEKSHIRIB KO'RING!

1. Funksiyaning aniqlanish sohasini toping:

1)  $y = \frac{8}{x-1}$ ;                      2)  $y = \sqrt{9-x^2}$ .

2. Funksiyaning grafigini yasang:

1)  $y = \sqrt{x}$ ;    2)  $y = \frac{6}{x}$ ;    3)  $y = -\frac{5}{x}$ ;    4)  $y = x^3$ .

Har bir funksiya uchun grafik bo'yicha:

a)  $y(2)$  ni toping;

b) agar  $y(x) = 3$  bo'lsa,  $x$  ning qiymatini toping;

d)  $y(x) > 0$ ,  $y(x) < 0$  bo'lgan oraliqlarni toping;

e) o'sish, kamayish oraliqlarini toping.

3. Funksiyaning juft va toqligini tekshiring:

1)  $y = 3x^6 + x^2$ ;                      2)  $y = 8x^5 - x$ .

4. Tenglamani yeching:

1)  $\sqrt{x-3} = 5$ ;                      2)  $\sqrt{3-x-x^2} = x$ .

252. Funksiyaning ko'rsatilgan oraliqda o'sishi yoki kamayishini aniqlang:

1)  $y = \frac{1}{(x-3)^2}$ ,  $x > 3$  oraliqda;    2)  $y = \frac{1}{(x-2)^3}$ ,  $x < 2$  oraliqda;

3)  $y = \sqrt[3]{x+1}$ ,  $x \geq 0$  oraliqda;    4)  $y = \frac{1}{\sqrt[3]{x+1}}$ ,  $x < -1$  oraliqda.

253. Funksiyaning juft yoki toqligini aniqlang:

1)  $y = x^6 - 3x^4 + x^2 - 2$ ;                      2)  $y = x^5 - x^3 + x$ ;

3)  $y = \frac{1}{(x-2)^2} + 1$ ;                      4)  $y = x^7 + x^5 + 1$ .

254. Funksiyaning xossalarini aniqlang va uning grafigini yasang:

1)  $y = \frac{1}{x^2}$ ;                      2)  $y = \frac{1}{x^3}$ ;                      3)  $y = \frac{1}{x^3} + 2$ ;

4)  $y = 3 - \frac{1}{x^2}$ ;    5)  $y = \frac{1}{(3-x)^2} + 1$ ;    6)  $y = \frac{1}{(x-1)^3} - 2$ .

255. Tengsizlikni yeching:

1)  $(3x+1)^4 > 625$ ;                      2)  $(3x^2+5x)^5 \leq 32$ .

256. Tenglamani yeching:

1)  $\sqrt{2x^2 + 5x - 3} = x + 1$ ;      2)  $\sqrt{3x^2 - 4x + 2} = x + 4$ ;

3)  $\sqrt{x + 11} = 1 + \sqrt{x}$ ;      4)  $\sqrt{x + 19} = 1 + \sqrt{x}$ ;

5)  $\sqrt{x + 3} + \sqrt{2x - 3} = 6$ ;      6)  $\sqrt{7 - x} + \sqrt{3x - 5} = 4$ .

257. Tengsizlikni yeching:

1)  $\sqrt{x^2 - 8x} > 3$ ;      2)  $\sqrt{x^2 - 3x} < 2$ ;

3)  $\sqrt{3x - 2} > x - 2$ ;      4)  $\sqrt{2x + 1} \leq x - 1$ .



*IV bobga doir sinov (test) mashqlari*

1. Funksiyaning aniqlanish sohasini toping:  $y = \sqrt{-x^2 + 3x - 2}$ .

A)  $1 \leq x \leq 2$ ;      B)  $1 < x < 2$ ;      C)  $x \geq 2, x \leq 1$ ;

D)  $-2 \leq x \leq -1$ ;      E)  $x \leq -1, x \geq 2$ .

2. Funksiyaning aniqlanish sohasini toping:  $y = \sqrt[4]{\frac{3x+2}{4x-5}}$ .

A)  $-\frac{2}{3} \leq x \leq \frac{5}{4}$ ;      B)  $x \leq -\frac{2}{3}, x > \frac{5}{4}$ ;      C)  $x \geq \frac{5}{4}$ ;

D)  $x < -\frac{2}{3}$ ;      E) to'g'ri javob berilmagan.

3. Funksiyaning aniqlanish sohasini toping:  $y = \sqrt{\frac{-x^2 + 13x - 22}{x - 2}}$ .

A)  $x < 2$ ;      B)  $2 < x < 11$ ;      C)  $x < 2, 2 < x < 11$ ;

D)  $x < -2$ ;      E)  $-2 \leq x \leq 11$ .

4. Quyidagi funksiyalarning qaysilari o'suvchi?

1)  $y = -x$ ;    2)  $y = -\frac{2}{x}$ ;    3)  $y = \sqrt{x}$ ;    4)  $y = \sqrt{x - 100}$ .

A) hammasi;    B) 1, 2, 3;    C) 1, 3, 4;    D) 2, 3, 4;    E) 1, 2, 4.

5. Quyidagi funksiyalarning qaysilari o'suvchi?

1)  $y = \sqrt[3]{-x}$ ;    2)  $y = \sqrt[5]{x^2}$ ;    3)  $y = -2x + 7$ ;    4)  $y = -\sqrt{3 - x}$ .

A) 1, 4;    B) 3, 4;    C) 2, 3;    D) 1, 2;    E) 2, 4.

6. Quyidagi funksiyalarning qaysilari kamayuvchi?

1)  $y = -\frac{1}{x^3}$ ; 2)  $y = -3x + 4$ ; 3)  $y = x^3 - 27$ ; 4)  $y = \sqrt[3]{8-x}$ .

A) 2, 4; B) 1, 2; C) 2, 3; D) 3, 4; E) 1, 4.

7. Quyidagi funksiyalarning qaysilari kamayuvchi?

1)  $y = \sqrt[5]{x^3}$ ; 2)  $y = \sqrt[3]{-x}$ ; 3)  $y = \frac{7}{\sqrt{3+2x}}$ ; 4)  $y = \sqrt[4]{x-16}$ .

A) 1, 2; B) 2, 3; C) 3, 4; D) 1, 3; E) 2, 4.

8. Funksiyalarning qaysilari juft funksiya?

1)  $y = x + \frac{1}{x}$ ; 2)  $y = x^2 + |x|$ ; 3)  $y = -3 + \frac{5}{x^4}$ ; 4)  $y = x^2 - \frac{3}{x}$ .

A) 1, 2; B) 3, 4; C) 2, 3; D) 1, 4; E) 1, 3.

9. Funksiyalarning qaysilari juft funksiya?

1)  $y = 3x^6 - 7x^4 + 5x^2 + 9$ ; 2)  $y = (x+1)^4 + 3(x+1)^2 - 6$ ;

3)  $y = 1 + 4x^5 + 7x^7$ ; 4)  $y = \frac{5x^4}{1+|x|}$ .

A) 1, 2; B) 2, 3; C) 3, 4; D) 1, 4; E) 2, 4.

10. Funksiyalarning qaysilari toq funksiya?

1)  $y = 6x$ ; 2)  $y = \sqrt[3]{x}$ ; 3)  $y = 4x + 7$ ; 4)  $y = 2x^3 - 10$ .

A) 2, 4; B) 2, 3; C) 3, 4; D) 1, 4; E) 1, 2.

11. Funksiyalarning qaysilari toq funksiya?

1)  $y = \frac{1}{x^{2k-1}}$ ; 2)  $y = x^2 + x^5$ ; 3)  $y = x^3 + 7$ ; 4)  $y = x^{2n+1}$  ( $k, n \in \mathbb{N}$ ).

A) 1, 4; B) 2, 3; C) 3, 4; D) 1, 2; E) to'g'ri javob berilmagan.

12.  $y = ax^2$  va  $y = \frac{k}{x}$  chiziqlar  $a$  va  $k$  ning qanday qiymatlarida

(3; 2) nuqtada kesishadi?

A)  $a = -\frac{2}{9}$ ,  $k = 6$ ; B)  $a = \frac{2}{9}$ ,  $k = 6$ ; C)  $a = 6$ ,  $k = \frac{2}{9}$ ;

D)  $a = -\frac{2}{9}$ ,  $k = -6$ ; E)  $a = 6$ ,  $k = -\frac{9}{2}$ .

13.  $k$  ning qanday qiymatlarida  $y = \frac{k}{x}$  giperbola bilan  $y = 2x + 5$  to'g'ri chiziq ikkita nuqtada keshishadi?  
 A)  $k < \frac{25}{8}$ ; B)  $k < -\frac{25}{8}$ ; C)  $k > -\frac{25}{8}$ ; D)  $k > \frac{25}{8}$ ; E)  $k = \frac{25}{8}$ .
14.  $k$  ning qanday qiymatlarida  $y = \frac{k}{x}$  giperbola bilan  $y = 6 - x$  to'g'ri chiziq bitta umumiy nuqtaga ega bo'ladi?  
 A) 10; B) -9; C) 8; D) 9; E) -10.
15.  $k$  ning qanday qiymatlarida  $y = \frac{k}{x}$  giperbola bilan  $y = 3 - 2x$  to'g'ri chiziq keshishmaydi?  
 A)  $k = \frac{9}{8}$ ; B)  $k < \frac{9}{8}$ ; C)  $k > -\frac{9}{8}$ ; D)  $k < -\frac{9}{8}$ ; E)  $k > \frac{9}{8}$ .
16.  $\sqrt{x-5} + \sqrt{10-x} = 3$  tenglamaning  $y = \sqrt{\frac{x^2-15x+50}{x^2-11x+24}}$  funksiyaning aniqlanish sohasiga tegishli ildizini toping.  
 A) 6; B) 9; C) -6; D) 3; E) 10.
17.  $\sqrt{x-50} \cdot \sqrt{100-x} > 0$  tengsizlikning butun yechimlari yig'indisini toping.  
 A) 3765; B) 3675; C) 49; D) 99; E) 3775.
18.  $\sqrt{2x^2 - 8x + 5} = x - 2$  tenglamani yeching.  
 A)  $4 - \sqrt{3}$ ; B)  $\sqrt{14}$ ; C)  $2 + \sqrt{3}$ ; D)  $2 - \sqrt{3}$ ; E)  $2 + \frac{\sqrt{6}}{2}$ .
19.  $\sqrt{2x-3} = 3-x$  tenglamani yeching.  
 A) 6; B)  $\frac{3}{2}$ ; C) 3; D) 2; E)  $\emptyset$ .
20.  $\sqrt{3-x} \cdot \sqrt{-2x^2 + 9x + 5} \geq 0$  tengsizlikning butun yechimlari sonini toping.  
 A) 6; B) 3; C) 5; D) 2; E) 4.



**Abu Rayhon Beruniy**  
(973–1048)

«Funksiya» soʻzi lotincha «*functio*» soʻzidan olingan boʻlib, u «sodir boʻlish», «bajarish» degan maʼnoni bildiradi. Funksiyaning dastlabki taʼriflari **G.Leybnis** (1646–1716), **I.Bernulli** (1667–1748), **N.I.Lobachevskiy** (1792–1856) asarlarida berilgan.

Funksiyaning hozirgi taʼrifini bilishmasa-da, qadimgi olimlar oʻzgaruvchi miqdorlar orasida funksional bogʻlanish boʻlishi lozimligini tushunishgan.

Toʻrt ming yildan avvalroq Babil olimlari radiusi  $r$  boʻlgan doira yuzi uchun – xatoligi sezilarli boʻlsa-da –  $S = 3r^2$  formulani chiqarishgan.

Sonning darajasi haqidagi ilk maʼlumotlar qadimgi bobilliklardan bizgacha yetib kelgan hitiklarda mavjud. Xususan, ularda natural sonlarning kvadratlari, kublari jadvallari berilgan.

Sonlarning kvadratlari, kublari jadvali, logarifmlar jadvali, trigonometrik jadvallar, kvadrat ildizlar jadvali miqdorlar orasidagi bogʻlanishning jadval usulida berilishi, xolos.

Buyuk qomusiy olim **Abu Rayhon Beruniy** ham oʻz asarlarida funksiya tushunchasidan, uning xossalaridan foydalangan. Abu Rayhon Beruniy mashhur «Qonuni Maʼsudiy» asarining 6- maqolasida argument va funksiyaning oʻzgarish oraliqlari, funksiyaning ishoralari va eng katta, eng kichik qiymatlarini taʼriflaydi.



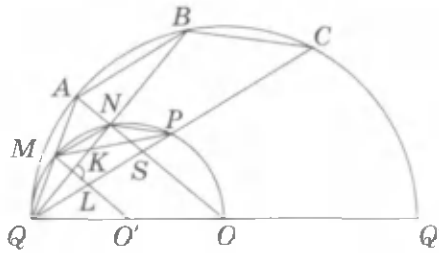

## 19- §.

## BURCHAKNING RADIAN O'LCHOVI

Aytaylik, vertikal to'g'ri chiziq markazi  $O$  nuqtada va radiusi 1 ga teng bo'lgan aylanaga  $P$  nuqtada urinsin (47- rasm). Bu to'g'ri chiziqni boshi  $P$  nuqtada bo'lgan son o'qi deb, yuqoriga yo'nalishni esa to'g'ri chiziqdagi musbat yo'nalish deb hisoblaymiz. Son o'qida uzunlik birligi sifatida aylananing radiusini olamiz. To'g'ri chiziqda bir nechta nuqtani belgilaylik:  $\pm 1, \pm \frac{\pi}{2}, \pm 3, \pm \pi$  ( $\pi$  - taqriban 3,14 ga teng bo'lgan irratsional son ekanligini eslatib o'tamiz). Bu to'g'ri chiziqni aylanadagi  $P$  nuqtaga mahkamlangan cho'zilmaydigan ip sifatida tasavvur qilib, uni fikran aylanaga o'ray boshlaymiz. Bunda son (o'qining) to'g'ri chizig'ining, masalan,  $1, \frac{\pi}{2}, -1, -2$  koordinatali nuqtalari aylananing, mos ravishda, shunday  $M_1, M_2, M_3, M_4$  nuqtalariga o'tadiki,  $PM_1$  yoyning uzunligi 1 ga teng,  $PM_2$  yoyning uzunligi  $\frac{\pi}{2}$  ga teng va hokazo bo'ladi.

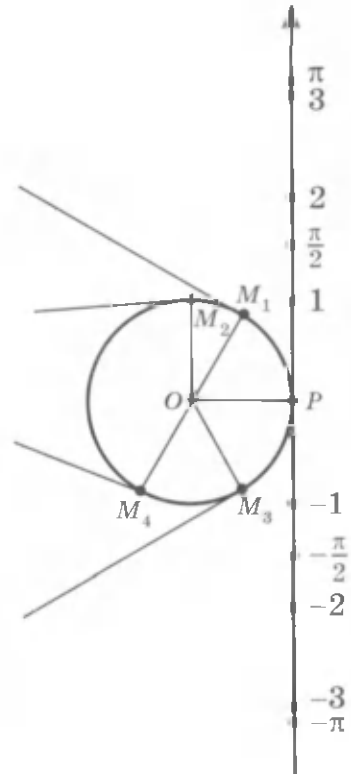

47- rasm.

Shunday qilib, to'g'ri chiziqning har bir nuqtasiga aylananing biror nuqtasi mos keltiriladi.

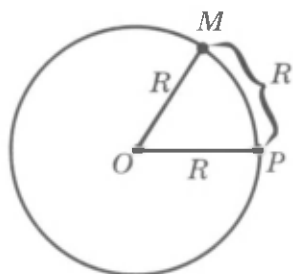

48- rasm.

*o'lbanyapti* deyiladi,  $POM_1$  ni esa 1 radian (1 rad) ga teng burchak deyiladi. Aylananing  $PM_1$  yoyining uzunligi radiusga teng ekanligini ta'kidlab o'tamiz.

Endi ixtiyoriy  $R$  radiusli aylananı qaraymiz va unda uzunligi  $R$  ga teng bo'lgan  $PM$  yoyini va  $POM$  burchakni belgilaymiz (48- rasm).



**Uzunligi aylana radiusiga teng bo'lgan yoyga tiralgan markaziy burchak 1 radian burchak deyiladi.**

1 rad burchakning gradus o'lchovini topaylik. Uzunligi  $\pi R$  (yarim aylana) bo'lgan yoy  $180^\circ$  li markaziy burchakni tortib turgani uchun uzunligi  $R$  bo'lgan yoy  $\pi$  marta kichik bo'lgan burchakni tortib turadi, ya'ni

$$1 \text{ rad} = \left(\frac{180}{\pi}\right)^\circ.$$

$\pi \approx 3,14$  bo'lgani uchun  $1 \text{ rad} \approx 57,3^\circ$  bo'ladi.

Agar burchak  $\alpha$  radiandan iborat bo'lsa, u holda uning gradus o'lchovi quyidagiga teng bo'ladi:

$$\alpha \text{ rad} = \left(\frac{180}{\pi} \alpha\right)^\circ. \quad (1)$$

**1- masala.** 1)  $\pi$  rad; 2)  $\frac{\pi}{2}$  rad; 3)  $\frac{3\pi}{4}$  rad ga teng burchakning gradus o'lchovini toping.

$\triangle$  (1) formula bo'yicha topamiz:

$$1) \pi \text{ rad} = 180^\circ; \quad 2) \frac{\pi}{2} \text{ rad} = 90^\circ; \quad 3) \frac{3\pi}{4} \text{ rad} = \left(\frac{180}{\pi} \cdot \frac{3\pi}{4}\right)^\circ = 135^\circ. \quad \blacktriangle$$

$1^\circ$  li burchakning radian o'lchovini topaylik.  $180^\circ$  li burchak  $\pi$  rad ga teng bo'lgani uchun

$$1^\circ = \frac{\pi}{180} \text{ rad}$$

bo'ladi.

Agar burchak  $\alpha$  gradusdan iborat bo'lsa, u holda uning radian o'lchovi

$$\alpha^\circ = \frac{\pi}{180} \alpha \text{ rad} \quad (2)$$

ga teng bo'ladi.

**2 - masala.** 1)  $45^\circ$  ga teng burchakning; 2)  $15^\circ$  ga teng burchakning radian o'lchovini toping.

$\triangle$  (2) formula bo'yicha topamiz:

$$1) 45^\circ = \frac{\pi}{180} \cdot 45 \text{ rad} = \frac{\pi}{4} \text{ rad};$$

$$2) 15^\circ = \frac{\pi}{180} \cdot 15 \text{ rad} = \frac{\pi}{12} \text{ rad}. \blacktriangle$$

Ko'proq uchrab turadigan burchaklarning gradus olcho'vlarini va ularga mos radian o'lchovlarini keltiramiz:

Gradus	0	30	45	60	90	180
Radian	0	$\frac{\pi}{6}$	$\frac{\pi}{4}$	$\frac{\pi}{3}$	$\frac{\pi}{2}$	$\pi$

Odatda burchakning o'lchovi radianlarda berilsa, «rad» nomi tushirib qoldiriladi.

Burchakning radian o'lchovi aylana yoylarining uzunliklarini hisoblash uchun qulay. 1 radian burchak uzunligi  $R$  radiusga teng yoyni tortib turgani uchun  $\alpha$  radian burchak

$$l = \alpha R \quad (3)$$

uzunlikdagi yoyni tortib turadi.

**3 - masala.** Shahar kurantlari minut milining uchi radiusi  $R \approx 0,8$  m bo'lgan aylana bo'ylab harakat qiladi. Bu milning uchi 15 min davomida qancha yo'lni bosib o'tadi?

△ Soat mili 15 min davomida  $\frac{\pi}{2}$  radianga teng burchakka buriladi.  
 (3) formula bo'yicha  $\alpha = \frac{\pi}{2}$  bo'lganda topamiz:

$$l = \frac{\pi}{2} R \approx \frac{3,14}{2} \cdot 0,8 \text{ m} \approx 1,3 \text{ m.}$$

**Javob:** 1,3 m. ▲

(3) formula aylana radiusi  $R=1$  bo'lganda ayniqsa sodda ko'rinishga ega bo'ladi. Bu holda yoy uzunligi shu yoy bilan tortilib turgan markaziy burchak kattaligiga teng, ya'ni  $l = \alpha$  bo'ladi. Radian o'lchovni matematika, fizika, mexanika va boshqa fanlarda qo'llanilishining qulayligi shu bilan izohlanadi.

**4-masala.** Radiusi  $R$  bo'lgan doiraviy sektor  $\alpha$  rad burchakka ega. Shu sektorning yuzi

$$S = \frac{R^2}{2} \alpha$$

ga teng ekanligini isbotlang, bunda  $0 < \alpha < \pi$ .

△  $\pi$  rad li doiraviy sektor (yarim doira)ning yuzi  $\frac{\pi R^2}{2}$  ga teng. Shuning uchun 1 rad li sektorning yuzi  $\pi$  marta kichik, ya'ni  $\frac{\pi R^2}{2} : \pi$ . Demak,  $\alpha$  rad li sektorning yuzi  $\frac{R^2}{2} \alpha$  ga teng. ▲

### Mashqlar

**258.** Graduslarda ifodalangan burchakning radian o'lchovini toping:

- 1)  $40^\circ$ ;                      2)  $120^\circ$ ;                      3)  $105^\circ$ ;                      4)  $150^\circ$ ;  
 5)  $75^\circ$ ;                      6)  $32^\circ$ ;                      7)  $100^\circ$ ;                      8)  $140^\circ$ .

**259.** Radianlarda ifodalangan burchakning gradus o'lchovini toping:

- 1)  $\frac{\pi}{6}$ ;                      2)  $\frac{\pi}{9}$ ;                      3)  $\frac{2}{3}\pi$ ;                      4)  $\frac{3}{4}\pi$ ;  
 5) 2;                      6) 4;                      7) 1,5;                      8) 0,36.

**260.** Sonni 0,01 gacha aniqlikda yozing:

- 1)  $\frac{\pi}{2}$ ;                      2)  $\frac{3}{2}\pi$ ;                      3)  $2\pi$ ;                      4)  $\frac{2}{3}\pi$ .

**261.** Sonlarni taqqoslang:

- 1)  $\frac{\pi}{2}$  va 2;                      2)  $2\pi$  va 6,7;                      3)  $\pi$  va  $3\frac{1}{5}$ ;  
 4)  $\frac{3}{2}\pi$  va 4,8;                      5)  $-\frac{\pi}{2}$  va  $-\frac{3}{2}$ ;                      6)  $-\frac{3}{2}\pi$  va  $-\sqrt{10}$ .

262. (Og'zaki.) a) teng tomonli uchburchak; b) teng yonli to'g'ri burchakli uchburchak; d) kvadrat; e) muntazam oltiburchak burchaklarining gradus va radian o'lchovlarini aniqlang.

263. Agar aylananing 0,36 m uzunlikdagi yoyi 0,9 rad markaziy burchakni tortib tursa, uning radiusini hisoblang.

264. Agar aylananing radiusi 1,5 sm ga teng bo'lsa, aylananing uzunligi 3 sm bo'lgan yoyi tortib turgan burchakning radian o'lchovini toping.

265. Doiraviy sektor yoyi  $\frac{3\pi}{4}$  rad burchakni tortib turadi. Agar doiraning radiusi 1 sm ga teng bo'lsa, sektorning yuzini toping.

266. Doiraning radiusi 2,5 sm ga teng, doiraviy sektorning yuzi esa  $6,25 \text{ sm}^2$  ga teng. Shu doiraviy sektor yoyi tortib turgan burchakni toping.

## 20- §.

### NUQTANI KOORDINATALAR BOSHI ATROFIDA BURISH

Avvalgi paragrafda son to'g'ri chizig'ining nuqtalari bilan aylana nuqtalari o'rtasida moslik o'rnatishning ko'rgazmali usulidan foydalanildi. Endi qanday qilib haqiqiy sonlar bilan aylananing nuqtalari o'rtasida aylana nuqtasini burish yordamida moslik o'rnatish mumkinligini ko'rsatamiz.

Koordinata tekisligida radiusi 1 ga teng va markazi koordinata boshida bo'lgan aylana qaraymiz. U *birlik aylana* deyiladi. Birlik aylananing nuqtasini koordinata boshi atrofida  $\alpha$  radian burchakka *burish tushunchasini* kiritamiz (bu yerda  $\alpha$  – istalgan haqiqiy son).

1. Aytaylik,  $\alpha > 0$  bo'lsin. Nuqta birlik aylana bo'ylab  $P$  nuqtadan soat mili yo'nalishiga qarama-qarshi harakat qilib,  $\alpha$  uzunlikdagi yo'lni bosib o'tdi, deylik (49- rasm). Yo'lning oxirgi nuqtasini  $M$  bilan belgilaymiz.

Bu holda  $M$  nuqta  $P$  nuqtani koordinata boshi atrofida  $\alpha$  radian burchakka burish bilan hosil qilinadi, deb aytamiz.

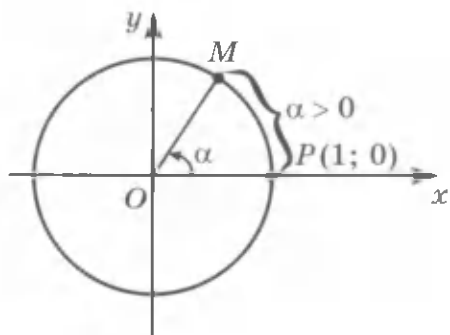

49- rasm.

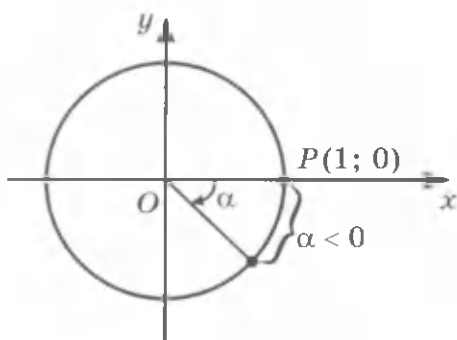

50- rasm.

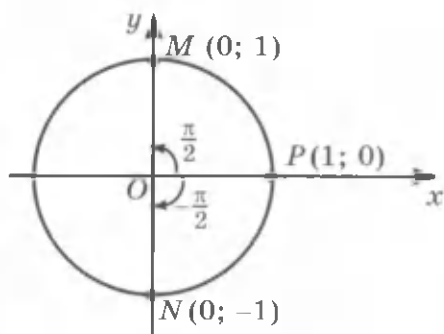

51- rasm.

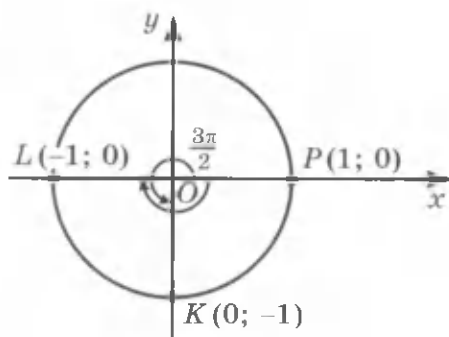

52- rasm.

2. Aytaylik,  $\alpha < 0$  bo'lsin. Bu holda  $\alpha$  radian burchakka burish harakat soat mili yo'nalishida sodir bo'lganligini va nuqta  $|\alpha|$  uzunlikdagi yo'lni bosib o'tganligini bildiradi (50- rasm).

0 rad ga burish nuqta o'z o'rnida qolganligini anglatadi.

**Misollar:**

1)  $P(1; 0)$  nuqtani  $\frac{\pi}{2}$  rad burchakka burishda  $(0; 1)$  koordinatali  $M$  nuqta hosil qilinadi (51- rasm).

2)  $P(1; 0)$  nuqtani  $-\frac{\pi}{2}$  rad burchakka burishda  $N(0; -1)$  nuqta hosil qilinadi (51- rasm).

3)  $P(1; 0)$  nuqtani  $\frac{3\pi}{2}$  rad burchakka burishda  $K(0; -1)$  nuqta hosil qilinadi (52- rasm).

4)  $P(1; 0)$  nuqtani  $-\pi$  rad burchakka burishda  $L(-1; 0)$  nuqta hosil qilinadi (52- rasm).

Geometriya kursida  $0^\circ$  dan  $180^\circ$  gacha bo'lgan burchaklar qaralgan. Birlik aylananing nuqtalarini koordinatalar boshi atrofida burishdan foydalanib,  $180^\circ$  dan katta burchaklarni, shuningdek, manfiy burchaklarni ham qarash mumkin. Burish burchagini graduslarda ham, radianlarda ham berish mumkin. Masalan,  $P(1; 0)$  nuqtani  $\frac{3\pi}{2}$  burchakka burish uni  $270^\circ$  ga burishni bildiradi;  $-\frac{\pi}{2}$  burchakka burish  $-90^\circ$  ga burishdir.

Ba'zi burchaklarni burishning radian va gradus o'lchovlari jadvalini keltiramiz (53- rasm).





$P(1; 0)$  nuqtani  $2\pi$  ga, ya'ni  $360^\circ$  ga burishda nuqta dastlabki holatiga qaytishini ta'kidlab o'tamiz (jadvalga qarang). Shu nuqtani  $-2\pi$  ga, ya'ni  $-360^\circ$  ga burishda u yana dastlabki holatiga qaytadi.

Nuqtani  $2\pi$  dan katta burchakka va  $-2\pi$  dan kichik burchakka burishga oid misollar qaraymiz. Masalan,  $\frac{9\pi}{2} = 2 \cdot 2\pi + \frac{\pi}{2}$  burchakka burishda nuqta soat mili harakatiga qarama-qarshi ikkita to'la aylanishni va yana  $\frac{\pi}{2}$  yo'lni bosib o'tadi (54- rasm).

$-\frac{9\pi}{2} = -2 \cdot 2\pi - \frac{\pi}{2}$  burchakka burishda nuqta soat mili harakati yo'nalishida ikkita to'la aylanadi va yana shu yo'nalishda  $\frac{\pi}{2}$  yo'lni bosadi (55- rasm).

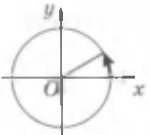
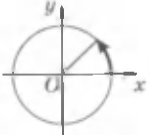
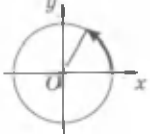
$P(1; 0)$  nuqtani  $\frac{9\pi}{2}$  burchakka burishda  $\frac{\pi}{2}$  burchakka burishdagi nuqtaning ayni o'zi hosil bo'lishini ta'kidlaymiz (54- rasm).

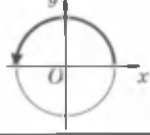
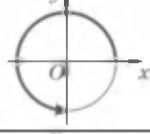
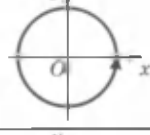
$-\frac{9\pi}{2}$  burchakka burishda  $-\frac{\pi}{2}$  burchakka burishdagi nuqtaning ayni o'zi hosil bo'ladi (55- rasm).

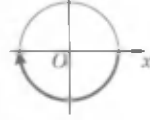
	$\frac{\pi}{6}$	$30^\circ$
	$\frac{\pi}{4}$	$45^\circ$
	$\frac{\pi}{3}$	$60^\circ$
	$\frac{\pi}{2}$	$90^\circ$
	$\pi$	$180^\circ$
	$\frac{3\pi}{2}$	$270^\circ$
	$2\pi$	$360^\circ$
	$-\frac{\pi}{2}$	$-90^\circ$
	$-\pi$	$-180^\circ$

53- rasm.

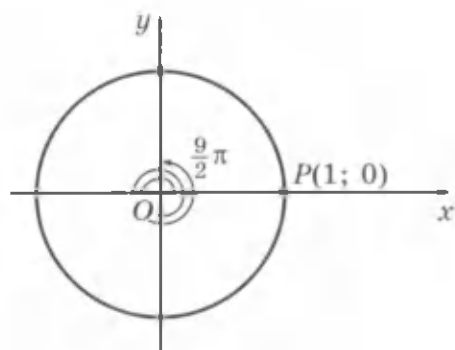

54- rasm.

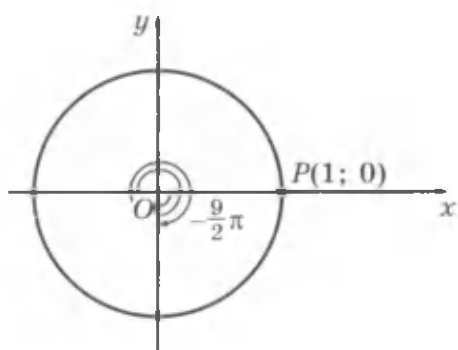

55- rasm.

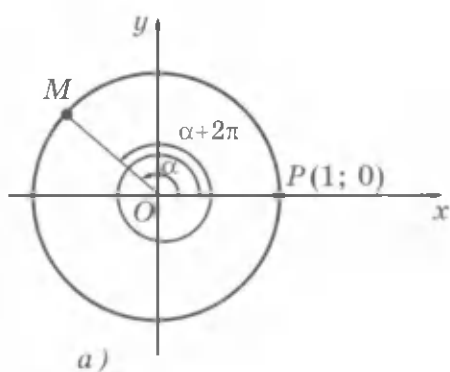

a)

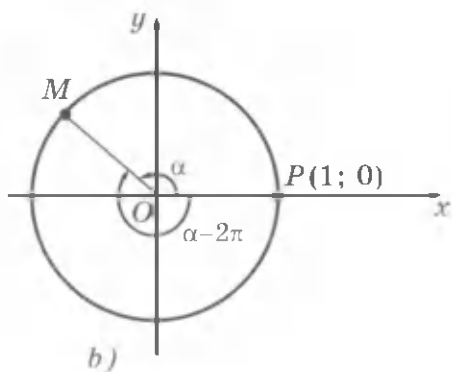

b)

56- rasm.

Umuman, agar  $\alpha = \alpha_0 + 2\pi k$  (bunda  $k$  – butun son) bo'lsa, u holda  $\alpha$  burchakka burishda  $\alpha_0$  burchakka burishdagi nuqtaning ayni o'zi hosil bo'ladi.

Shunday qilib, har bir haqiqiy  $\alpha$  songa birlik aylananing  $(1; 0)$  nuqtasini  $\alpha$  rad burchakka burish bilan hosil qilinadigan birgina nuqtasi mos keladi.

Biroq, birlik aylananing ayni bir  $M$  nuqtasiga  $(P(1; 0)$  nuqtani burishda  $M$  nuqta hosil bo'ladigan) cheksiz ko'p  $\alpha + 2\pi k$  haqiqiy sonlar mos keladi,  $k$  – butun son (56- rasm).

**1 - masala.**  $P(1; 0)$  nuqtani: 1)  $7\pi$ ; 2)  $-\frac{5\pi}{2}$  burchakka burishdan hosil bo'lgan nuqtaning koordinatalarini toping.



$\triangle 1) 7\pi = \pi + 2\pi \cdot 3$  bo'lgani uchun  $7\pi$  ga burishda  $\pi$  ga burishdagi nuqtaning o'zi, ya'ni  $(-1; 0)$  koordinatali nuqta hosil bo'ladi.

2)  $-\frac{5\pi}{2} = -\frac{\pi}{2} - 2\pi$  bo'lgani uchun  $-\frac{5\pi}{2}$  ga burishda  $-\frac{\pi}{2}$  ga burishdagi nuqtaning o'zi, ya'ni  $(0; -1)$  koordinatali nuqta hosil bo'ladi.  $\blacktriangle$

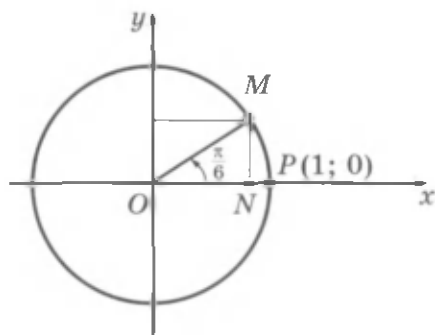

57- rasm.

**2- masala.**  $(\frac{\sqrt{3}}{2}; \frac{1}{2})$  nuqtani hosil qilish uchun  $(1; 0)$  nuqtani burish kerak bo'lgan barcha burchaklarni yozing.

$\triangle NOM$  to'g'ri burchakli uchburchakdan (57- rasm)  $NOM$  burchak  $\frac{\pi}{6}$  ga tengligi kelib chiqadi, ya'ni mumkin bo'lgan burish burchaklaridan biri  $\frac{\pi}{6}$  ga teng. Shuning uchun  $(\frac{\sqrt{3}}{2}; \frac{1}{2})$  nuqtani hosil qilish uchun  $(1; 0)$  nuqtani burish kerak bo'lgan barcha burchaklar bunday ifodalanadi:  $\frac{\pi}{6} + 2\pi k$ , bu yerda  $k$  - istalgan butun son, ya'ni  $k = 0; \pm 1; \pm 2; \dots$   $\blacktriangle$

### Mashqlar

267. Birlik aylananing  $P(1; 0)$  nuqtasini:

- 1)  $90^\circ$ ; 2)  $-\pi$ ; 3)  $180^\circ$ ; 4)  $-\frac{\pi}{2}$ ; 5)  $270^\circ$ ; 6)  $2\pi$   
burchakka burish natijasida hosil bo'lgan nuqtalarining koordinatalarini toping.

268. Birlik aylana  $P(1; 0)$  nuqtani:

- 1)  $\frac{\pi}{4}$ ; 2)  $-\frac{\pi}{3}$ ; 3)  $-\frac{2}{3}\pi$ ; 4)  $\frac{3}{4}\pi$ ;  
5)  $\frac{\pi}{2} + 2\pi$ ; 6)  $-\pi - 2\pi$ ; 7)  $\frac{\pi}{4} - 4\pi$ ; 8)  $-\frac{\pi}{3} + 6\pi$

burchakka burish natijasida hosil bo'lgan nuqtani belgilang.

269.  $P(1; 0)$  nuqtani:

- 1)  $2,1\pi$ ; 2)  $2\frac{2}{3}\pi$ ; 3)  $-\frac{13}{3}\pi$ ; 4)  $-\frac{25}{4}\pi$ ; 5)  $727^\circ$ ; 6)  $460^\circ$

burchakka burish natijasida hosil bo'lgan nuqta joylashgan koordinatalar choragini aniqlang.

270.  $P(1; 0)$  nuqtani:

- 1)  $3\pi$ ; 2)  $-\frac{7}{2}\pi$ ; 3)  $-\frac{15}{2}\pi$ ;

- 4)  $5\pi$ ; 5)  $540^\circ$ ; 6)  $810^\circ$

burchakka burish natijasida hosil bo'lgan nuqtaning koordinatalarini toping.

271. 1)  $(-1; 0)$ ; 2)  $(1; 0)$ ; 3)  $(0; 1)$ ; 4)  $(0; -1)$  nuqtalarni hosil qilish uchun  $P(1; 0)$  nuqtani burish kerak bo'lgan barcha burchaklarni yozing.

272.  $P(1; 0)$  nuqtani berilgan:

- 1) 1; 2) 2,75; 3) 3,16; 4) 4,95

burchakka burish natijasida hosil bo'lgan nuqta joylashgan koordinatalar choragini toping.

273. Agar:

- 1)  $a = 6,7\pi$ ; 2)  $a = 9,8\pi$ ; 3)  $a = 4\frac{1}{2}\pi$ ;

- 4)  $a = 7\frac{1}{3}\pi$ ; 5)  $a = \frac{11}{2}\pi$ ; 6)  $a = \frac{17}{3}\pi$

bo'lsa,  $a = x + 2\pi k$  tenglik bajariladigan  $x$  sonni (bu yerda  $0 \leq x < 2\pi$ ) va  $k$  natural sonni toping.

274. Birlik aylanada  $P(1; 0)$  nuqtani:

- 1)  $\frac{\pi}{4} \pm 2\pi$ ; 2)  $-\frac{\pi}{3} \pm 2\pi$ ; 3)  $\frac{2\pi}{3} \pm 6\pi$ ; 4)  $-\frac{3\pi}{4} \pm 8\pi$ ;

- 5)  $4,5\pi$ ; 6)  $5,5\pi$ ; 7)  $-6\pi$ ; 8)  $-7\pi$

burchakka burishdan hosil bo'lgan nuqtani yasang.

275.  $P(1; 0)$  nuqtani:

- 1)  $-\frac{3\pi}{2} + 2\pi k$ ; 2)  $\frac{5\pi}{2} + 2\pi k$ ; 3)  $\frac{7\pi}{2} + 2\pi k$ ; 4)  $-\frac{9\pi}{2} + 2\pi k$

burchakka (bu yerda  $k$  - butun son) burishdan hosil bo'lgan nuqtaning koordinatalarini toping.

276. (1; 0) nuqtani:

1)  $\left(-\frac{1}{2}; \frac{\sqrt{3}}{2}\right)$ ; 2)  $\left(\frac{\sqrt{3}}{2}; -\frac{1}{2}\right)$ ; 3)  $\left(\frac{\sqrt{2}}{2}; -\frac{\sqrt{2}}{2}\right)$ ; 4)  $\left(-\frac{\sqrt{2}}{2}; \frac{\sqrt{2}}{2}\right)$

koordinatali nuqta hosil qilish uchun burish kerak bo'lgan barcha burchaklarni yozing.

## 21- §.

### BURCHAKNING SINUSI, KOSINUSI, TANGENSI VA KOTANGENSI TA'RIFLARI

Geometriya kursida graduslarda ifodalangan burchakning sinusi, kosinusi va tangensi kiritilgan edi. Bu burchak  $0^\circ$  dan  $180^\circ$  gacha bo'lgan oraliqda qaralgan. Ixtiyoriy burchakning sinusi va kosinusi quyidagicha ta'riflanadi:

**!** 1-ta'rif.  $\alpha$  burchakning sinusi deb (1; 0) nuqtani koordinatalar boshi atrofida  $\alpha$  burchakka burish natijasida hosil bo'lgan nuqtaning ordinatasiga aytiladi ( $\sin\alpha$  kabi belgilanadi).

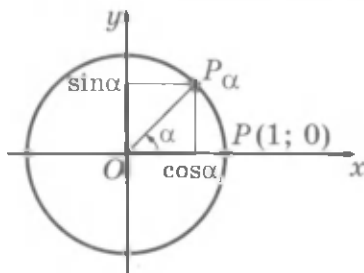

**!** 2-ta'rif.  $\alpha$  burchakning kosinusi deb (1; 0) nuqtani koordinatalar boshi atrofida  $\alpha$  burchakka burish natijasida hosil bo'lgan nuqtaning absissasiga aytiladi ( $\cos\alpha$  kabi belgilanadi).

Bu ta'riflarda  $\alpha$  burchak graduslarda, shuningdek radianlarda ham ifodalanishi mumkin.

Masalan, (1; 0) nuqtani  $\frac{\pi}{2}$  burchakka, ya'ni  $90^\circ$  ga burishda (0; 1) nuqta hosil qilinadi. (0; 1) nuqtaning ordinatasi 1 ga teng, shuning uchun

$$\sin \frac{\pi}{2} = \sin 90^\circ = 1;$$

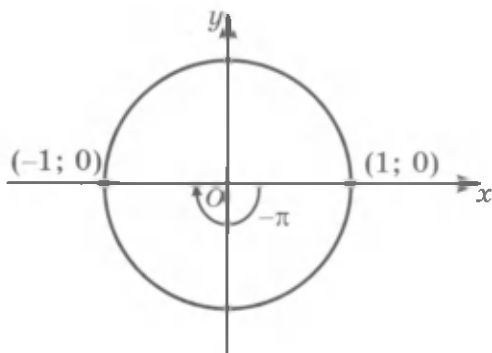

58- rasm.

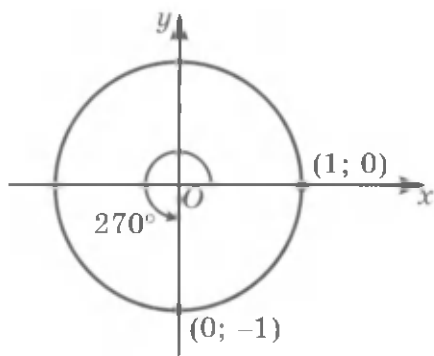

59- rasm.

bu nuqtaning absissasi 0 ga teng, shuning uchun

$$\cos \frac{\pi}{2} = \cos 90^\circ = 0.$$

Burchak  $0^\circ$  dan  $180^\circ$  gacha oraliqda bo'lgan holda sinus va kosinuslarning ta'riflari geometriya kursidan ma'lum bo'lgan sinus va kosinus ta'riflari bilan mos tushishini ta'kidlaymiz.

Masalan,

$$\sin \frac{\pi}{6} = \sin 30^\circ = \frac{1}{2}, \quad \cos \pi = \cos 180^\circ = -1.$$

**1- masala.**  $\sin(-\pi)$  va  $\cos(-\pi)$  ni toping.

$\triangle$  (1; 0) nuqtani  $-\pi$  burchakka burganda u (-1; 0) nuqtaga o'tadi (58- rasm). Shuning uchun  $\sin(-\pi) = 0$ ,  $\cos(-\pi) = -1$ .  $\blacktriangle$

**2- masala.**  $\sin 270^\circ$  va  $\cos 270^\circ$  ni toping.

$\triangle$  (1; 0) nuqtani  $270^\circ$  ga burganda u (0; -1) nuqtaga o'tadi (59- rasm). Shuning uchun  $\cos 270^\circ = 0$ ,  $\sin 270^\circ = -1$ .  $\blacktriangle$

**3- masala.**  $\sin t = 0$  tenglamani yeching.

$\triangle$   $\sin t = 0$  tenglamani yechish — bu sinusi nolga teng bo'lgan barcha burchaklarni topish demakdir.

Birlik aylana da ordinatasi nolga teng bo'lgan ikkita nuqta bor: (1; 0) va (-1; 0) (58- rasm). Bu nuqtalar (1; 0) nuqtani  $0, \pi, 2\pi, 3\pi$  va hokazo, shuningdek,  $-\pi, -2\pi, -3\pi$  va hokazo burchaklarga burish bilan hosil qilinadi.

Demak,  $t = k\pi$  bo'lganda (bunda  $k$  — istalgan butun son)  $\sin t = 0$  bo'ladi.  $\blacktriangle$

Butun sonlar to'plami  $\mathbf{Z}$  harfi bilan belgilanadi.  $k$  son  $\mathbf{Z}$  ga tegishli ekanligini belgilash uchun  $k \in \mathbf{Z}$  yozuvdan foydalaniladi (« $k$  son  $\mathbf{Z}$  ga tegishli» deb o'qiladi). Shuning uchun 3-masala javobini bunday yozish mumkin:

$$t = \pi k, k \in \mathbf{Z}.$$

**4 - masala.**  $\cos t = 0$  tenglamani yeching.

$\triangle$  Birlik aylanada absissasi nolga teng bo'lgan ikkita nuqta bor:  $(0, 1)$  va  $(0, -1)$  (60-rasm).

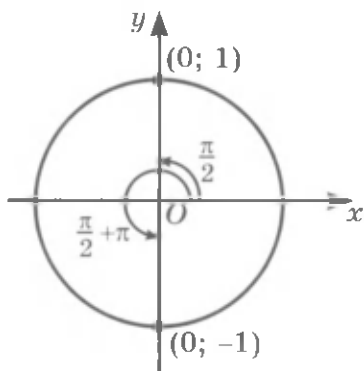

60-rasm.

Bu nuqtalar  $(1; 0)$  nuqtani  $\frac{\pi}{2}$ ,  $\frac{\pi}{2} + \pi$ ,  $\frac{\pi}{2} + 2\pi$  va hokazo, shuningdek,  $\frac{\pi}{2} - \pi$ ,  $\frac{\pi}{2} - 2\pi$  va hokazo burchaklarga, ya'ni  $\frac{\pi}{2} + k\pi$  (bunda  $k \in \mathbf{Z}$ ) burchaklarga burish bilan hosil qilinadi.

**J a v o b:**  $t = \frac{\pi}{2} + \pi k, k \in \mathbf{Z}$ .  $\blacktriangle$

**5-masala.** Tenglamani yeching: 1)  $\sin t = 1$ ; 2)  $\cos t = 1$ .

$\triangle$  1) Birlik aylananing  $(0; 1)$  nuqtasi birga teng ordinataga ega. Bu nuqta  $(1; 0)$  nuqtani  $\frac{\pi}{2} + 2\pi k, k \in \mathbf{Z}$  burchakka burish bilan hosil qilinadi.

2)  $(1; 0)$  nuqtani  $2k\pi, k \in \mathbf{Z}$  burchakka burish bilan hosil qilingan nuqtaning absissasi birga teng bo'ladi.

**J a v o b:**  $t = \frac{\pi}{2} + 2\pi k$  bo'lganda  $\sin t = 1$ ,  
 $t = 2\pi k$  bo'lganda  $\cos t = 1, k \in \mathbf{Z}$ .  $\blacktriangle$



**3-ta'rif.**  $\alpha$  burchakning tangensi deb  $\alpha$  burchak sinusining uning kosinusiga nisbatiga aytiladi ( $\operatorname{tg} \alpha$  kabi belgilanadi).

Shunday qilib,  $\operatorname{tg} \alpha = \frac{\sin \alpha}{\cos \alpha}$ .

Masalan,  $\operatorname{tg} 0^\circ = \frac{\sin 0^\circ}{\cos 0^\circ} = \frac{0}{1} = 0$ ,  $\operatorname{tg} \frac{\pi}{4} = \frac{\sin \frac{\pi}{4}}{\cos \frac{\pi}{4}} = \frac{\frac{\sqrt{2}}{2}}{\frac{\sqrt{2}}{2}} = 1$ .

Ba'zan  $\alpha$  burchakning kotangensidan foydalaniladi ( $\text{ctg}\alpha$  kabi belgilanadi). U  $\text{ctg}\alpha = \frac{\cos\alpha}{\sin\alpha}$  formula bilan aniqlanadi.

Masalan,

$$\text{ctg} 270^\circ = \frac{\cos 270^\circ}{\sin 270^\circ} = \frac{0}{-1} = 0, \quad \text{ctg} \frac{\pi}{4} = \frac{1}{\text{tg} \frac{\pi}{4}} = \frac{1}{1} = 1.$$

$\sin\alpha$  va  $\cos\alpha$  lar ixtiyoriy burchak uchun ta'riflanganligini, ularning qiymatlari esa  $-1$  dan  $1$  gacha oraliqda ekanligini ta'kidlab o'tamiz;  $\text{tg}\alpha = \frac{\sin\alpha}{\cos\alpha}$  faqat  $\cos\alpha \neq 0$  bo'lgan burchaklar uchun, ya'ni  $\alpha = \frac{\pi}{2} + \pi k$ ,  $k \in \mathbb{Z}$  dan boshqa ixtiyoriy burchaklar uchun aniqlangan.

Sinus, kosinus, tangens va kotangenslarning ko'proq uchrab turaligan qiymatlari jadvalini keltiramiz.

$\alpha$	0 (0°)	$\frac{\pi}{6}$ (30°)	$\frac{\pi}{4}$ (45°)	$\frac{\pi}{3}$ (60°)	$\frac{\pi}{2}$ (90°)	$\pi$ (180°)	$\frac{3}{2}\pi$ (270°)	$2\pi$ (360°)
$\sin\alpha$	0	$\frac{1}{2}$	$\frac{\sqrt{2}}{2}$	$\frac{\sqrt{3}}{2}$	1	0	-1	0
$\cos\alpha$	1	$\frac{\sqrt{3}}{2}$	$\frac{\sqrt{2}}{2}$	$\frac{1}{2}$	0	-1	0	1
$\text{tg}\alpha$	0	$\frac{1}{\sqrt{3}}$	1	$\sqrt{3}$	Mavjud emas	0	Mavjud emas	0
$\text{ctg}\alpha$	Mavjud emas	$\sqrt{3}$	1	$\frac{1}{\sqrt{3}}$	0	Mavjud emas	0	Mavjud emas

**6-masala.** Hisoblang:

$$4 \sin \frac{\pi}{6} + \sqrt{3} \cos \frac{\pi}{6} - \text{tg} \frac{\pi}{4}.$$

$\triangle$  Jadvaldan foydalanib, hosil qilamiz:

$$4 \sin \frac{\pi}{6} + \sqrt{3} \cos \frac{\pi}{6} - \text{tg} \frac{\pi}{4} = 4 \cdot \frac{1}{2} + \sqrt{3} \cdot \frac{\sqrt{3}}{2} - 1 = 2,5. \blacktriangle$$

Sinus, kosinus, tangens va kotangenslarning bu jadvalga kirmagan burchaklar uchun qiymatlarini V.M.Bradingning to'rt xonali matematik jadvallaridan, shuningdek mikrokalculator yordamida topish mumkin.

Agar har bir haqiqiy  $x$  songa  $\sin x$  son mos keltirilsa, u holda haqiqiy sonlar to'plamida  $y = \sin x$  funksiya berilgan bo'ladi. Shun-

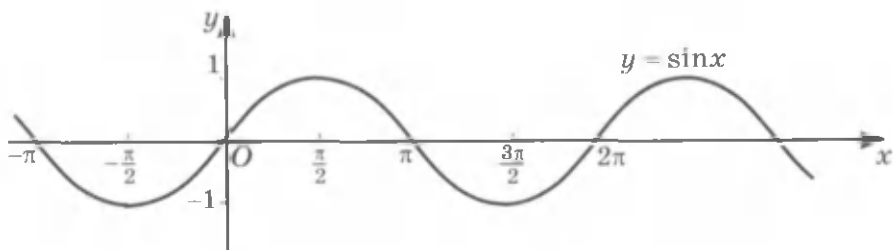

61- rasm.

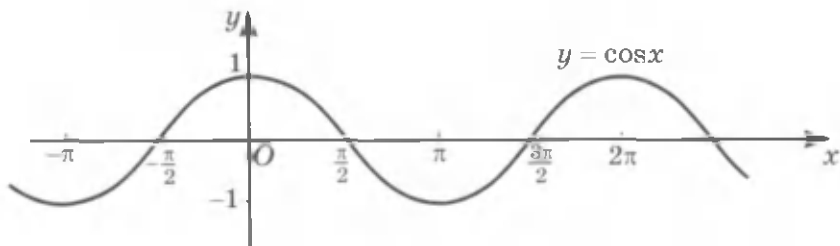

62- rasm.

ga o'xshash,  $y = \cos x$ ,  $y = \operatorname{tg} x$  va  $y = \operatorname{ctg} x$  funksiyalar beriladi.  $y = \cos x$  funksiya barcha  $x \in \mathbf{R}$  da aniqlangan,  $y = \operatorname{tg} x$  funksiya  $x \neq \frac{\pi}{2} + \pi k, k \in \mathbf{Z}$ ,  $y = \operatorname{ctg} x$  esa  $x \neq \pi k, k \in \mathbf{Z}$  bo'lganda aniqlangan.  $y = \sin x$  va  $y = \cos x$  funksiyalarning grafiklari 61- va 62- rasmlarda tasvirlangan.

$y = \sin x$ ,  $y = \cos x$ ,  $y = \operatorname{tg} x$ ,  $y = \operatorname{ctg} x$  funksiyalar *trigonometrik funksiyalar* deyiladi.

### Mashqlar

277. Hisoblang:

- 1)  $\sin \frac{3\pi}{4}$ ;      2)  $\cos \frac{2\pi}{3}$ ;      3)  $\operatorname{tg} \frac{5\pi}{6}$ ;      4)  $\sin(-90^\circ)$ ;  
 5)  $\cos(-180^\circ)$ ;      6)  $\operatorname{tg}\left(-\frac{\pi}{4}\right)$ ;      7)  $\cos(-135^\circ)$ ;      8)  $\sin\left(-\frac{5\pi}{4}\right)$ .

278. Agar:

- 1)  $\sin \alpha = \frac{1}{2}$ ;      2)  $\sin \alpha = -\frac{\sqrt{2}}{2}$ ;      3)  $\cos \alpha = \frac{\sqrt{3}}{2}$ ;  
 4)  $\cos \alpha = -\frac{1}{2}$ ;      5)  $\sin \alpha = -0,6$ ;      6)  $\cos \alpha = \frac{1}{3}$

bo'lsa, birlik aylanada  $\alpha$  burchakka mos keluvchi nuqtani tasvirlang.

Hisoblang (279–281):

279. 1)  $\sin \frac{\pi}{2} + \sin \frac{3\pi}{2}$ ;    2)  $\sin\left(-\frac{\pi}{2}\right) + \cos \frac{\pi}{2}$ ;    3)  $\sin \pi - \cos \pi$ ;  
4)  $\sin 0 - \cos 2\pi$ ;    5)  $\sin \pi + \sin 1,5\pi$ ;    6)  $\cos 0 - \cos \frac{3}{2}\pi$ .

280. 1)  $\operatorname{tg} \pi + \cos \pi$ ;    2)  $\operatorname{tg} 0^\circ - \operatorname{tg} 180^\circ$ ;  
3)  $\operatorname{tg} \pi + \sin \pi$ ;    4)  $\cos \pi - \operatorname{tg} 2\pi$ .

281. 1)  $3 \sin \frac{\pi}{6} + 2 \cos \frac{\pi}{6} - \operatorname{tg} \frac{\pi}{3}$ ;    2)  $5 \sin \frac{\pi}{6} + 3 \operatorname{tg} \frac{\pi}{4} - \cos \frac{\pi}{4} - 10 \operatorname{tg} \frac{\pi}{4}$ ;  
3)  $\left(2 \operatorname{tg} \frac{\pi}{6} - \operatorname{tg} \frac{\pi}{3}\right) : \cos \frac{\pi}{6}$ ;    4)  $\sin \frac{\pi}{3} \cos \frac{\pi}{6} - \operatorname{tg} \frac{\pi}{4}$ .

282. Tenglamani yeching:

1)  $2 \sin x = 0$ ;    2)  $\frac{1}{2} \cos x = 0$ ;    3)  $\cos x - 1 = 0$ ;    4)  $1 - \sin x = 0$ .

283. (Og'zaki.)  $\sin \alpha$  yoki  $\cos \alpha$ :

1) 0,49;    2) -0,875;    3)  $-\sqrt{2}$ ;    4)  $2 - \sqrt{2}$

ga teng bo'lishi mumkinmi?

284.  $\alpha$  ning berilgan qiymatida ifodaning qiymatini toping:

1)  $2 \sin \alpha + \sqrt{2} \cos \alpha$ , bunda  $\alpha = \frac{\pi}{4}$ ;  
2)  $0,5 \cos \alpha - \sqrt{3} \sin \alpha$ , bunda  $\alpha = 60^\circ$ ;  
3)  $\sin 3\alpha - \cos 2\alpha$ , bunda  $\alpha = \frac{\pi}{6}$ ;  
4)  $\cos \frac{\alpha}{2} + \sin \frac{\alpha}{3}$ , bunda  $\alpha = \frac{\pi}{2}$ .

285. Tenglamani yeching:

1)  $\sin x = -1$ ;    2)  $\cos x = -1$ ;    3)  $\sin 3x = 0$ ;  
4)  $\cos 0,5x = 0$ ;    5)  $\cos 2x - 1 = 0$ ;    6)  $1 - \cos 3x = 0$ .

286. Tenglamani yeching:

1)  $\sin(x + \pi) = -1$ ;    2)  $\sin \frac{1}{2}(x + 1) = 0$ ;    3)  $\cos(x + \pi) = -1$ ;  
4)  $\cos 2(x + 1) - 1 = 0$ ;    5)  $\sin 3(x - 2) = 0$ ;    6)  $1 - \cos 3(x - 1) = 0$ .



## 1. Sinus va kosinusning ishoralari

Aytaylik,  $(1; 0)$  nuqta birlik aylana bo'yicha soat mili harakatiga qarama-qarshi harakat qilmoqda. Bu holda birinchi chorak (kvadrant)da joylashgan nuqtalarning ordinatalari va absissalari musbat. Shuning uchun, agar  $0 < \alpha < \frac{\pi}{2}$  bo'lsa,  $\sin \alpha > 0$  va  $\cos \alpha > 0$  bo'ladi (63, 64- rasmlar).

Ikkinchi chorakda joylashgan nuqtalar uchun ordinatalar musbat, absissalar esa manfiy. Shuning uchun, agar  $\frac{\pi}{2} < \alpha < \pi$  bo'lsa,  $\sin \alpha > 0$ ,  $\cos \alpha < 0$  bo'ladi (63, 64- rasmlar). Shunga o'xshash, uchinchi chorakda  $\sin \alpha < 0$ ,  $\cos \alpha < 0$ , to'rtinchi chorakda esa  $\sin \alpha < 0$ ,  $\cos \alpha > 0$  (63, 64- rasmlar). Nuqtaning aylana bo'yicha bundan keyingi harakatida sinus va kosinuslarning ishoralari nuqta qaysi chorakda turganligi bilan aniqlanadi.

Agar  $(1; 0)$  nuqta soat mili yo'nalishida harakat qilsa, *u holda ham sinus va kosinusning ishoralari nuqta qaysi chorakda joylashganiga qarab aniqlanadi*; bu 63, 64- rasmlarda ko'rsatilgan.

**1- masala.** Burchak sinus va kosinuslarining ishoralarini aniqlang: 1)  $\frac{3\pi}{4}$ ; 2)  $745^\circ$ ; 3)  $-\frac{5\pi}{7}$ .

$\triangle$  1)  $\frac{3\pi}{4}$  burchakka birlik aylananing ikkinchi choragida joylashgan nuqta mos keladi. Shuning uchun  $\sin \frac{3\pi}{4} > 0$ ,  $\cos \frac{3\pi}{4} < 0$ .

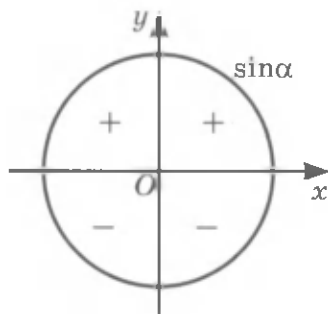

63- rasm.

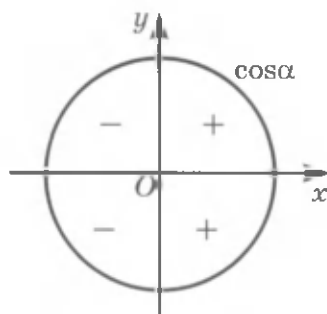

64- rasm.

2)  $745^\circ = 2 \cdot 360^\circ + 25^\circ$  bo'lgani uchun (1; 0) nuqtani  $745^\circ$  ga burishga birinchi chorakda joylashgan nuqta mos keladi. Shuning uchun  $\sin 745^\circ > 0$ ,  $\cos 745^\circ > 0$ .

3)  $-\pi < -\frac{5\pi}{7} < -\frac{\pi}{2}$  bo'lgani uchun (1; 0) nuqtani  $-\frac{5\pi}{7}$  burchakka burganda uchinchi chorakda joylashgan nuqta hosil qilinadi. Shuning uchun  $\sin(-\frac{5\pi}{7}) < 0$ ,  $\cos(-\frac{5\pi}{7}) < 0$ . ▲

## 2. Tangensning ishoralari

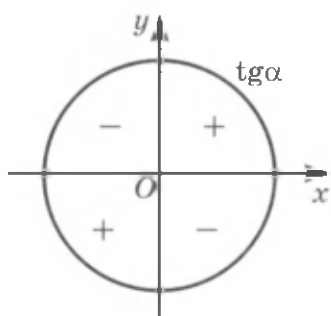

65- rasm.

Ta'rifga ko'ra  $\operatorname{tg} \alpha = \frac{\sin \alpha}{\cos \alpha}$ . Shuning uchun, agar  $\sin \alpha$  va  $\cos \alpha$  bir xil ishoraga ega bo'lsa,  $\operatorname{tg} \alpha > 0$ ,  $\sin \alpha$  va  $\cos \alpha$  qarama-qarshi ishoralarga ega bo'lsa,  $\operatorname{tg} \alpha < 0$  bo'ladi. Tangensning ishoralari 65- rasmدا tasvirlangan.

$\operatorname{ctg} \alpha$  ning ishoralari  $\operatorname{tg} \alpha$  ning ishoralari bilan bir xildir.

**2- masala.** Burchak' tangensining ishoralarini aniqlang:

- 1)  $260^\circ$ ; 2) 3.

△ 1)  $180^\circ < 260^\circ < 270^\circ$  bo'lgani uchun  $\operatorname{tg} 260^\circ > 0$ .

2)  $\frac{\pi}{2} < 3 < \pi$  bo'lgani uchun  $\operatorname{tg} 3 < 0$ . ▲

## Mashqlar

287. Agar:

- 1)  $\alpha = \frac{\pi}{6}$ ;                      2)  $\alpha = \frac{3\pi}{4}$ ;                      3)  $\alpha = 210^\circ$ ;  
 4)  $\alpha = -210^\circ$ ;                      5)  $\alpha = 735^\circ$ ;                      6)  $\alpha = 848^\circ$

bo'lsa, (1; 0) nuqtani  $\alpha$  burchakka burishda hosil bo'lgan nuqta qaysi chorakda yotishini aniqlang.

288. Agar:

$$1) \alpha = \frac{5\pi}{4}; \quad 2) \alpha = \frac{5\pi}{6}; \quad 3) \alpha = -\frac{5}{8}\pi;$$
$$4) \alpha = -\frac{4}{3}\pi; \quad 5) \alpha = 740^\circ; \quad 6) \alpha = 510^\circ$$

bo'lsa,  $\sin\alpha$  sonning ishorasini aniqlang.

289. Agar:

$$1) \alpha = \frac{2}{3}\pi; \quad 2) \alpha = \frac{7}{6}\pi; \quad 3) \alpha = -\frac{3\pi}{4};$$
$$4) \alpha = -\frac{2}{5}\pi; \quad 5) \alpha = 290^\circ; \quad 6) \alpha = -150^\circ$$

bo'lsa,  $\cos\alpha$  sonning ishorasini aniqlang.

290. Agar:

$$1) \alpha = \frac{5}{6}\pi; \quad 2) \alpha = \frac{12}{5}\pi; \quad 3) \alpha = -\frac{3}{5}\pi; \quad 4) \alpha = -\frac{5}{4}\pi;$$
$$5) \alpha = 190^\circ; \quad 6) \alpha = 283^\circ; \quad 7) \alpha = 172^\circ; \quad 8) \alpha = 200^\circ$$

bo'lsa,  $\operatorname{tg}\alpha$  va  $\operatorname{ctg}\alpha$  sonlarning ishoralarini aniqlang.

291. Agar:

$$1) \pi < \alpha < \frac{3\pi}{2}; \quad 2) \frac{3\pi}{2} < \alpha < \frac{7\pi}{4};$$
$$3) \frac{7}{4}\pi < \alpha < 2\pi; \quad 4) 2\pi < \alpha < 2,5\pi$$

bo'lsa,  $\sin\alpha$ ,  $\cos\alpha$ ,  $\operatorname{tg}\alpha$ ,  $\operatorname{ctg}\alpha$  sonlarning ishoralarini aniqlang.

292. Agar:

$$1) \alpha = 1; \quad 2) \alpha = 3; \quad 3) \alpha = -3,4; \quad 4) \alpha = -1,3$$

bo'lsa,  $\sin\alpha$ ,  $\cos\alpha$ ,  $\operatorname{tg}\alpha$  sonlarning ishoralarini aniqlang.

293.  $0 < \alpha < \frac{\pi}{2}$  bo'lsin. Sonning ishorasini aniqlang:

$$1) \sin\left(\frac{\pi}{2} - \alpha\right); \quad 2) \cos\left(\frac{\pi}{2} + \alpha\right); \quad 3) \operatorname{tg}\left(\frac{3}{2}\pi - \alpha\right); \quad 4) \sin(\pi - \alpha);$$
$$5) \cos(\alpha - \pi); \quad 6) \operatorname{tg}(\alpha - \pi); \quad 7) \cos\left(\alpha - \frac{\pi}{2}\right); \quad 8) \operatorname{ctg}\left(\alpha - \frac{\pi}{2}\right).$$

294. Sinus va kosinuslarning ishoralari bir xil (har xil) bo'ladigan  $\alpha$  argumentning 0 dan  $2\pi$  gacha oraliqda joylashgan barcha qiymatlarini toping.

295. Sonning ishorasini aniqlang:

$$1) \sin\frac{2\pi}{3} \sin\frac{3\pi}{4}; \quad 2) \cos\frac{2\pi}{3} \cos\frac{\pi}{6}; \quad 3) \frac{\sin\frac{2\pi}{3}}{\cos\frac{3\pi}{4}}; \quad 4) \operatorname{tg}\frac{5\pi}{4} + \sin\frac{\pi}{4}.$$

296. Ifodalarning qiymatlarini taqqoslang:

1)  $\sin 0,7$  va  $\sin 4$ ; 2)  $\cos 1,3$  va  $\cos 2,3$ .

297. Tenglamani yeching:

1)  $\sin(5\pi + x) = 1$ ; 2)  $\cos(x + 3\pi) = 0$ ;

3)  $\cos\left(\frac{5}{2}\pi + x\right) = -1$ ; 4)  $\sin\left(\frac{9}{2}\pi + x\right) = -1$ .

298. Agar:

1)  $\sin \alpha + \cos \alpha = -1,4$ ;

2)  $\sin \alpha - \cos \alpha = 1,4$

bo'lsa,  $\alpha$  songa mos keluvchi nuqta qaysi chorakda joylashgan?

299. (Beruniy masalasi.) Tog'ning balandligi  $h = BC$  va  $\alpha = \angle ABD$  burchak ma'lum bo'lsa, Yer radiusi  $R$  ni toping (66- rasm).

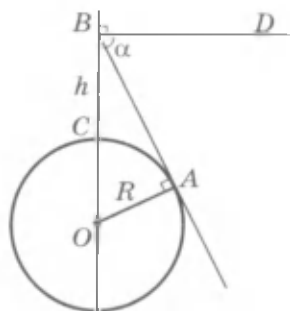

66- rasm.

## 23- §. AYNI BIR BURCHAKNING SINUSI, KOSINUSI VA TANGENSI ORASIDAGI MUNOSABATLAR

*Sinus bilan kosinus orasidagi munosabatni aniqlaymiz.*

Aytaylik, birlik aylananing  $M(x; y)$  nuqtasi  $(1; 0)$  nuqtani  $\alpha$  burchakka burish natijasida hosil qilingan bo'lsin (67- rasm). U holda sinus va kosinusning ta'rifiga ko'ra

$$x = \cos \alpha, \quad y = \sin \alpha$$

bo'ladi.

$M$  nuqta birlik aylanaga tegishli, shuning uchun uning  $(x; y)$  koordinatalari  $x^2 + y^2 = 1$  tenglamani qanoatlantiradi.

Demak,

$$\sin^2 \alpha + \cos^2 \alpha = 1. \quad (1)$$

(1) tenglik  $\alpha$  ning istalgan qiymatida bajariladi va *asosiy trigonometrik ayniyat* deyiladi.

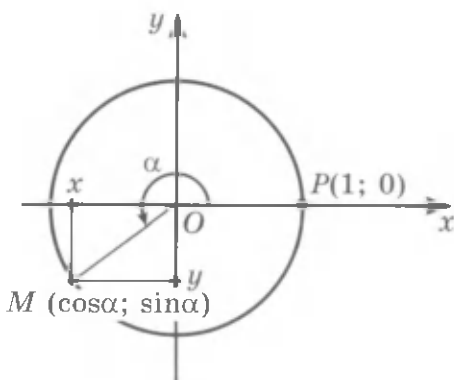

67- rasm.

(1) tenglikdan  $\sin \alpha$  ni  $\cos \alpha$  orqali va, aksincha,  $\cos \alpha$  ni  $\sin \alpha$  orqali ifodalash mumkin:

$$\sin \alpha = \pm \sqrt{1 - \cos^2 \alpha}, \quad (2)$$

$$\cos \alpha = \pm \sqrt{1 - \sin^2 \alpha}. \quad (3)$$

Bu formulalarda ildiz oldidagi ishora formulaning chap qismida turgan ifodaning ishorasi bilan aniqlanadi.

**1 - masala.** Agar  $\cos \alpha = -\frac{3}{5}$  va  $\pi < \alpha < \frac{3\pi}{2}$  bo'lsa,  $\sin \alpha$  ni hisoblang.

$\triangle$  (2) formuladan foydalanamiz.  $\pi < \alpha < \frac{3\pi}{2}$  bo'lgani uchun  $\sin \alpha < 0$  bo'ladi, shuning uchun (2) formulada ildiz oldiga «-» ishorasini qo'yish kerak:

$$\sin \alpha = -\sqrt{1 - \cos^2 \alpha} = -\sqrt{1 - \frac{9}{25}} = -\frac{4}{5}. \blacktriangle$$

**2 - masala.** Agar  $\sin \alpha = \frac{1}{3}$  va  $-\frac{\pi}{2} < \alpha < 0$  bo'lsa,  $\cos \alpha$  ni hisoblang.

$\triangle$   $-\frac{\pi}{2} < \alpha < 0$  bo'lgani uchun  $\cos \alpha > 0$  bo'ladi va shuning uchun (3) formulada ildiz oldiga «+» ishorasini qo'yish kerak:

$$\cos \alpha = \sqrt{1 - \sin^2 \alpha} = \sqrt{1 - \frac{1}{9}} = \frac{2\sqrt{2}}{3}. \blacktriangle$$

Endi *tangens bilan kotangens orasidagi bog'lanishni* aniqlaymiz. Tangens va kotangensning ta'rifiga ko'ra:

$$\operatorname{tg} \alpha = \frac{\sin \alpha}{\cos \alpha}, \quad \operatorname{ctg} \alpha = \frac{\cos \alpha}{\sin \alpha}.$$

Bu tengliklarni ko'paytirib,

$$\operatorname{tg} \alpha \cdot \operatorname{ctg} \alpha = 1 \quad (4)$$

tenglikni hosil qilamiz. (4) tenglikdan  $\operatorname{tg} \alpha$  ni  $\operatorname{ctg} \alpha$  orqali, va aksincha,  $\operatorname{ctg} \alpha$  ni  $\operatorname{tg} \alpha$  orqali ifodalash mumkin:

$$\operatorname{tg} \alpha = \frac{1}{\operatorname{ctg} \alpha}, \quad (5)$$

$$\operatorname{ctg} \alpha = \frac{1}{\operatorname{tg} \alpha}. \quad (6)$$

(4)–(6) tengliklar  $\alpha \neq \frac{\pi}{2}k, k \in \mathbb{Z}$  bo'lganda o'rinlidir.

**3-masala.** Agar  $\operatorname{tg}\alpha = 13$  bo'lsa,  $\operatorname{ctg}\alpha$  ni hisoblang.

$\triangle$  (6) formula bo'yicha topamiz:  $\operatorname{ctg}\alpha = \frac{1}{\operatorname{tg}\alpha} = \frac{1}{13}$ .  $\blacktriangle$

**4-masala.** Agar  $\sin\alpha = 0,8$  va  $\frac{\pi}{2} < \alpha < \pi$  bo'lsa,  $\operatorname{tg}\alpha$  ni hisoblang.

$\triangle$  (3) formula bo'yicha  $\cos\alpha$  ni topamiz.  $\frac{\pi}{2} < \alpha < \pi$  bo'lgani uchun  $\cos\alpha < 0$  bo'ladi. Shuning uchun

$$\cos\alpha = -\sqrt{1 - \sin^2\alpha} = -\sqrt{1 - 0,64} = -0,6.$$

Demak, 
$$\operatorname{tg}\alpha = \frac{\sin\alpha}{\cos\alpha} = \frac{0,8}{-0,6} = -\frac{4}{3}. \blacktriangle$$

Asosiy trigonometrik ayniyatdan va tangensning ta'rifidan foydalanib, *tangens bilan kosinus orasidagi munosabatni* topamiz.

$\triangle$   $\cos\alpha \neq 0$  deb faraz qilib,  $\sin^2\alpha + \cos^2\alpha = 1$  tenglikning ikkala qismini  $\cos^2\alpha$  ga bo'lamiz:  $\frac{\cos^2\alpha + \sin^2\alpha}{\cos^2\alpha} = \frac{1}{\cos^2\alpha}$ , bundan

$$\boxed{1 + \operatorname{tg}^2\alpha = \frac{1}{\cos^2\alpha}}. \blacktriangle \quad (7)$$

Agar  $\cos\alpha \neq 0$  bo'lsa, ya'ni  $\alpha \neq \frac{\pi}{2} + \pi k$ ,  $k \in \mathbf{Z}$  bo'lsa, (7) formula to'g'ri bo'ladi.

(7) formuladan tangensni kosinus va kosinusni tangens orqali ifodalash mumkin.

**5-masala.** Agar  $\cos\alpha = -\frac{3}{5}$  va  $\frac{\pi}{2} < \alpha < \pi$  bo'lsa,  $\operatorname{tg}\alpha$  ni hisoblang.

$\triangle$  (7) formuladan hosil qilamiz:

$$\operatorname{tg}^2\alpha = \frac{1}{\cos^2\alpha} - 1 = \frac{1}{\left(-\frac{3}{5}\right)^2} - 1 = \frac{16}{9}.$$

Tangens ikkinchi chorakda manfiy, shuning uchun  $\operatorname{tg}\alpha = -\frac{4}{3}$ .  $\blacktriangle$

**6-masala.** Agar  $\operatorname{tg}\alpha = 3$  va  $\pi < \alpha < \frac{3\pi}{2}$  bo'lsa,  $\cos\alpha$  ni hisoblang.

$\triangle$  (7) formuladan topamiz:

$$\cos^2\alpha = \frac{1}{1 + \operatorname{tg}^2\alpha} = \frac{1}{10}.$$

$\pi < \alpha < \frac{3\pi}{2}$  bo'lgani uchun  $\cos\alpha < 0$  va shuning uchun  $\cos\alpha = -\sqrt{0,1}$ .  $\blacktriangle$

**300.** Agar:

1)  $\cos \alpha = \frac{5}{13}$  va  $\frac{3\pi}{2} < \alpha < 2\pi$  bo'lsa,  $\sin \alpha$  va  $\operatorname{tg} \alpha$  ni;

2)  $\sin \alpha = 0,8$  va  $\frac{\pi}{2} < \alpha < \pi$  bo'lsa,  $\cos \alpha$  va  $\operatorname{tg} \alpha$  ni;

3)  $\cos \alpha = -\frac{3}{5}$  va  $\frac{\pi}{2} < \alpha < \pi$  bo'lsa,  $\sin \alpha$ ,  $\operatorname{tg} \alpha$  va  $\operatorname{ctg} \alpha$  ni;

4)  $\sin \alpha = -\frac{2}{5}$  va  $\pi < \alpha < \frac{3\pi}{2}$  bo'lsa,  $\cos \alpha$ ,  $\operatorname{tg} \alpha$  va  $\operatorname{ctg} \alpha$  ni;

5)  $\operatorname{tg} \alpha = \frac{15}{8}$  va  $\pi < \alpha < \frac{3\pi}{2}$  bo'lsa,  $\sin \alpha$  va  $\cos \alpha$  ni;

6)  $\operatorname{ctg} \alpha = -3$  va  $\frac{3\pi}{2} < \alpha < 2\pi$  bo'lsa,  $\sin \alpha$  va  $\cos \alpha$  ni hisoblang.

**301.** Asosiy trigonometrik ayniyat yordamida tengliklar bir vaqtda bajarilishi yoki bajarilmasligini aniqlang:

1)  $\sin \alpha = 1$  va  $\cos \alpha = 1$ ;      2)  $\sin \alpha = 0$  va  $\cos \alpha = -1$ ;

3)  $\sin \alpha = -\frac{4}{5}$  va  $\cos \alpha = -\frac{3}{5}$ ;      4)  $\sin \alpha = \frac{1}{3}$  va  $\cos \alpha = -\frac{1}{2}$ .

**302.** Tengliklar bir vaqtda bajarilishi mumkinmi:

1)  $\sin \alpha = \frac{1}{5}$  va  $\operatorname{tg} \alpha = \frac{1}{\sqrt{24}}$ ;      2)  $\operatorname{ctg} \alpha = \frac{\sqrt{7}}{3}$  va  $\cos \alpha = \frac{3}{4}$ ?

**303.** Aytaylik,  $\alpha$  to'g'ri burchakli uchburchakning burchaklaridan biri bo'lsin. Agar  $\sin \alpha = \frac{2\sqrt{10}}{11}$  bo'lsa,  $\cos \alpha$  va  $\operatorname{tg} \alpha$  ni toping.

**304.** Teng yonli uchburchakning uchidagi burchagining tangensi  $2\sqrt{2}$  ga teng. Shu burchakning kosinusini toping.

**305.** Agar  $\cos^4 \alpha - \sin^4 \alpha = \frac{1}{8}$  bo'lsa,  $\cos \alpha$  ni toping.

**306.** 1)  $\sin \alpha = \frac{2\sqrt{3}}{5}$  bo'lsa,  $\cos \alpha$  ni toping;

2)  $\cos \alpha = -\frac{1}{\sqrt{5}}$  bo'lsa,  $\sin \alpha$  ni toping.

**307.**  $\operatorname{tg} \alpha = 2$  ekanligi ma'lum. Ifodaning qiymatini toping:

1)  $\frac{\operatorname{ctg} \alpha + \operatorname{tg} \alpha}{\operatorname{ctg} \alpha - \operatorname{tg} \alpha}$ ;      2)  $\frac{\sin \alpha - \cos \alpha}{\sin \alpha + \cos \alpha}$ ;

3)  $\frac{2 \sin \alpha + 3 \cos \alpha}{3 \sin \alpha - 5 \cos \alpha}$ ;      4)  $\frac{\sin^2 \alpha + 2 \cos^2 \alpha}{\sin^2 \alpha - \cos^2 \alpha}$ .

308.  $\sin\alpha + \cos\alpha = \frac{1}{2}$  ekanligi ma'lum. 1)  $\sin\alpha \cos\alpha$ ; 2)  $\sin^3\alpha + \cos^3\alpha$  ifodalarning qiymatlarini toping.

309. Tenglamani yeching:

- 1)  $2\sin x + \sin^2 x + \cos^2 x = 1$ ;                      2)  $\sin^2 x - 2 = \sin x - \cos^2 x$ ;  
3)  $2\cos^2 x - 1 = \cos x - 2\sin^2 x$ ;                      4)  $3 - \cos x = 3\cos^2 x + 3\sin^2 x$ .

## 24- §. TRIGONOMETRIK AYNIYATLAR

1- masala.  $\alpha \neq \pi k, k \in \mathbb{Z}$  bo'lganda

$$1 + \operatorname{ctg}^2 \alpha = \frac{1}{\sin^2 \alpha} \quad (1)$$

tenglikning o'rinli ekanligini isbotlang.

△ Kotangensning ta'rifiga ko'ra  $\operatorname{ctg} \alpha = \frac{\cos \alpha}{\sin \alpha}$  va shuning uchun

$$1 + \operatorname{ctg}^2 \alpha = 1 + \frac{\cos^2 \alpha}{\sin^2 \alpha} = \frac{\sin^2 \alpha + \cos^2 \alpha}{\sin^2 \alpha} = \frac{1}{\sin^2 \alpha}. \quad (2)$$

Bu shakl almashtirishlar to'g'ri, chunki  $\alpha \neq \pi k, k \in \mathbb{Z}$  bo'lganda  $\sin \alpha \neq 0$ . ▲

(1) tenglik  $\alpha$  ning mumkin bo'lgan barcha (joiz) qiymatlari uchun o'rinli, ya'ni uning chap va o'ng qismlari ma'noga ega bo'ladigan barcha qiymatlari uchun to'g'ri bo'ladi. Bu kabi tengliklar *ayniyatlar* deyiladi, bunday tengliklarni isbotlashga doir masalalar ayniyatlarni isbotlashga doir masalalar deyiladi.

Kelgusida ayniyatlarni isbotlashda, agar masalaning shartida talab qilinmagan bo'lsa, burchaklarning joiz qiymatlarini izlab o'tirmaymiz.

2- masala. Ayniyatni isbotlang:  $\cos^2 \alpha = (1 - \sin \alpha)(1 + \sin \alpha)$ .

$$\triangle (1 - \sin \alpha)(1 + \sin \alpha) = 1 - \sin^2 \alpha = \cos^2 \alpha. \quad \blacktriangle$$

3- masala. Ayniyatni isbotlang:  $\frac{\cos \alpha}{1 - \sin \alpha} = \frac{1 + \sin \alpha}{\cos \alpha}$ .

△ Bu ayniyatni isbotlash uchun uning chap va o'ng qismlarining ayirmasi nolga teng ekanligini ko'rsatamiz:



$$\frac{\cos \alpha}{1 - \sin \alpha} - \frac{1 + \sin \alpha}{\cos \alpha} = \frac{\cos^2 \alpha - (1 - \sin^2 \alpha)}{\cos \alpha (1 - \sin \alpha)} = \frac{\cos^2 \alpha - \cos^2 \alpha}{\cos \alpha (1 - \sin \alpha)} = 0. \blacktriangle$$

1-3- masalalarni yechishda *ayniyatlarni isbotlashning quyidagi usullaridan* foydalanildi: o'ng qismida shakl almashtirib, uni chap qismiga tengligini ko'rsatish; o'ng va chap qismlarining ayirmasi nolga tengligini ko'rsatish. Ba'zan ayniyatlarni isbotlashda uning o'ng va chap qismlarining shaklini almashtirib bir xil ifodaga keltirish qulay.

**4- masala.** Ayniyatni isbotlang:  $\frac{1 - \operatorname{tg}^2 \alpha}{1 + \operatorname{tg}^2 \alpha} = \cos^4 \alpha - \sin^4 \alpha.$

$$\triangle \frac{1 - \operatorname{tg}^2 \alpha}{1 + \operatorname{tg}^2 \alpha} = \frac{1 - \frac{\sin^2 \alpha}{\cos^2 \alpha}}{1 + \frac{\sin^2 \alpha}{\cos^2 \alpha}} = \frac{\cos^2 \alpha - \sin^2 \alpha}{\cos^2 \alpha + \sin^2 \alpha} = \cos^2 \alpha - \sin^2 \alpha.$$

$$\cos^4 \alpha - \sin^4 \alpha = (\cos^2 \alpha - \sin^2 \alpha)(\cos^2 \alpha + \sin^2 \alpha) = \cos^2 \alpha - \sin^2 \alpha.$$

Ayniyat isbotlandi, chunki uning chap va o'ng qismlari  $\cos^2 \alpha - \sin^2 \alpha$  ga teng.  $\blacktriangle$

**5- masala.** Ifodani soddalashtiring:  $\frac{1}{\operatorname{tg} \alpha + \operatorname{ctg} \alpha}.$

$$\triangle \frac{1}{\operatorname{tg} \alpha + \operatorname{ctg} \alpha} = \frac{1}{\frac{\sin \alpha}{\cos \alpha} + \frac{\cos \alpha}{\sin \alpha}} = \frac{\sin \alpha \cos \alpha}{\sin^2 \alpha + \cos^2 \alpha} = \sin \alpha \cos \alpha. \blacktriangle$$

Trigonometrik ifodalarni soddalashtirishga doir masalalar yechishda, agar masalaning shartida talab qilinmagan bo'lsa, burchaklarning qabul qilishi mumkin bo'lgan joiz qiymatlarini topmaymiz.

## Mashqlar

**310.** Ayniyatni isbotlang:

1)  $(1 - \cos \alpha)(1 + \cos \alpha) = \sin^2 \alpha;$     2)  $2 - \sin^2 \alpha - \cos^2 \alpha = 1;$

3)  $\frac{\sin^2 \alpha}{1 - \sin^2 \alpha} = \operatorname{tg}^2 \alpha;$     4)  $\frac{\cos^2 \alpha}{1 - \cos^2 \alpha} = \operatorname{ctg}^2 \alpha;$

5)  $\frac{1}{1 + \operatorname{tg}^2 \alpha} + \sin^2 \alpha = 1;$     6)  $\frac{1}{1 + \operatorname{ctg}^2 \alpha} + \cos^2 \alpha = 1.$

**311.** Ifodani soddalashtiring:

1)  $\cos \alpha \cdot \operatorname{tg} \alpha - 2 \sin \alpha;$     2)  $\cos \alpha - \sin \alpha \cdot \operatorname{ctg} \alpha;$

3)  $\frac{\sin^2 \alpha}{1 + \cos \alpha};$     4)  $\frac{\cos^2 \alpha}{1 - \sin \alpha}.$

**312.** Ifodani soddalashtiring va uning son qiymatini toping:

1)  $\frac{\sin^2 \alpha - 1}{1 - \cos^2 \alpha}$ , bunda  $\alpha = \frac{\pi}{6}$ ;      2)  $\frac{1}{\cos^2 \alpha} - 1$ , bunda  $\alpha = \frac{\pi}{3}$ ;

3)  $\cos^2 \alpha + \operatorname{ctg}^2 \alpha + \sin^2 \alpha$ , bunda  $\alpha = \frac{\pi}{6}$ ;

4)  $\cos^2 \alpha + \operatorname{tg}^2 \alpha + \sin^2 \alpha$ , bunda  $\alpha = \frac{\pi}{3}$ .

**313.** Ayniyatni isbotlang:

1)  $(1 - \sin^2 \alpha)(1 + \operatorname{tg}^2 \alpha) = 1$ ;      2)  $\sin^2 \alpha(1 + \operatorname{ctg}^2 \alpha) - \cos^2 \alpha = \sin^2 \alpha$ .

---

**314.**  $\alpha$  ning barcha joiz qiymatlarida quyidagi ifoda ayni bir xil qiymatni qabul qilishini, ya'ni  $\alpha$  ga bog'liq emasligini isbotlang:

1)  $(1 + \operatorname{tg}^2 \alpha) \cos^2 \alpha$ ;      2)  $\sin^2 \alpha(1 + \operatorname{ctg}^2 \alpha)$ ;

3)  $\left(1 + \operatorname{tg}^2 \alpha + \frac{1}{\sin^2 \alpha}\right) \sin^2 \alpha \cos^2 \alpha$ ;      4)  $\frac{1 + \operatorname{tg}^2 \alpha}{1 + \operatorname{ctg}^2 \alpha} - \operatorname{tg}^2 \alpha$ .

**315.** Ayniyatni isbotlang:

1)  $(1 - \cos 2\alpha)(1 + \cos 2\alpha) = \sin^2 2\alpha$ ;      2)  $\frac{\sin \alpha - 1}{\cos^2 \alpha} = -\frac{1}{1 + \sin \alpha}$ ;

3)  $\cos^4 \alpha - \sin^4 \alpha = \cos^2 \alpha - \sin^2 \alpha$ ;

4)  $(\sin^2 \alpha - \cos^2 \alpha)^2 + 2 \cos^2 \alpha \sin^2 \alpha = \sin^4 \alpha + \cos^4 \alpha$ ;

5)  $\frac{\sin \alpha}{1 + \cos \alpha} + \frac{1 + \cos \alpha}{\sin \alpha} = \frac{2}{\sin \alpha}$ ;      6)  $\frac{\sin \alpha}{1 - \cos \alpha} = \frac{1 + \cos \alpha}{\sin \alpha}$ ;

7)  $\frac{1}{1 + \operatorname{tg}^2 \alpha} + \frac{1}{1 + \operatorname{ctg}^2 \alpha} = 1$ ;      8)  $\operatorname{tg}^2 \alpha - \sin^2 \alpha = \operatorname{tg}^2 \alpha \sin^2 \alpha$ .

**316.** Ifodani soddalashtiring va uning son qiymatini toping:

1)  $\frac{(\sin \alpha + \cos \alpha)^2}{\sin^2 \alpha} - (1 + \operatorname{ctg}^2 \alpha)$ , bunda  $\alpha = \frac{\pi}{3}$ ;

2)  $(1 + \operatorname{tg}^2 \alpha) - \frac{(\sin \alpha - \cos \alpha)^2}{\cos^2 \alpha}$ , bunda  $\alpha = \frac{\pi}{6}$ .

**317.** Agar  $\sin \alpha - \cos \alpha = 0,6$  bo'lsa,  $\sin \alpha \cos \alpha$  ning qiymatini toping.

**318.** Agar  $\cos \alpha - \sin \alpha = 0,2$  bo'lsa,  $\cos^3 \alpha - \sin^3 \alpha$  ning qiymatini toping.

**319.** Tenglamani yeching:

1)  $3 \cos^2 x - 2 \sin x = 3 - 3 \sin^2 x$ ;

2)  $\cos^2 x - \sin^2 x = 2 \sin x - 1 - 2 \sin^2 x$ .

Aytaylik, birlik aylananing  $M_1$  va  $M_2$  nuqtalari  $P(1; 0)$  nuqtani mos ravishda  $\alpha$  va  $-\alpha$  burchaklarga burish natijasida hosil qilingan bo'lsin (68- rasm). U holda  $Ox$  o'q  $M_1OM_2$  burchakni teng ikkiga bo'ladi va shuning uchun  $M_1$  va  $M_2$  nuqtalar  $Ox$  o'qqa nisbatan simmetrik joylashgan. Bu nuqtalarning absissalari bir xil bo'ladi, ordinatalari esa faqat ishoralari bilan farq qiladi.  $M_1$  nuqta  $(\cos\alpha; \sin\alpha)$  koordinatalarga,  $M_2$  nuqta  $(\cos(-\alpha); \sin(-\alpha))$  koordinatalarga ega. Shuning uchun

$$\sin(-\alpha) = -\sin\alpha, \cos(-\alpha) = \cos\alpha. \quad (1)$$

Tangensning ta'rifidan foydalanib, hosil qilamiz:

$$\operatorname{tg}(-\alpha) = \frac{\sin(-\alpha)}{\cos(-\alpha)} = \frac{-\sin\alpha}{\cos\alpha} = -\operatorname{tg}\alpha.$$

Demak,

$$\operatorname{tg}(-\alpha) = -\operatorname{tg}\alpha. \quad (2)$$

Shunga o'xshash,

$$\operatorname{ctg}(-\alpha) = -\operatorname{ctg}\alpha. \quad (3)$$

(1) formula  $\alpha$  ning istalgan qiymatida o'rinli bo'ladi, (2) formula esa  $\alpha \neq \frac{\pi}{2} + \pi k, k \in Z$  bo'lganda o'rinlidir.

Agar  $\alpha \neq \pi k, k \in Z$  bo'lsa, u holda  $\operatorname{ctg}(-\alpha) = -\operatorname{ctg}\alpha$  bo'lishini ko'rsatish mumkin.

(1)–(2) formulalar manfiy burchaklar uchun sinus, kosinus va tangensning qiymatlarini topishga imkon beradi.

Masalan:

$$\sin\left(-\frac{\pi}{6}\right) = -\sin\frac{\pi}{6} = -\frac{1}{2},$$

$$\cos\left(-\frac{\pi}{4}\right) = \cos\frac{\pi}{4} = \frac{\sqrt{2}}{2},$$

$$\operatorname{tg}\left(-\frac{\pi}{3}\right) = -\operatorname{tg}\frac{\pi}{3} = -\sqrt{3}.$$

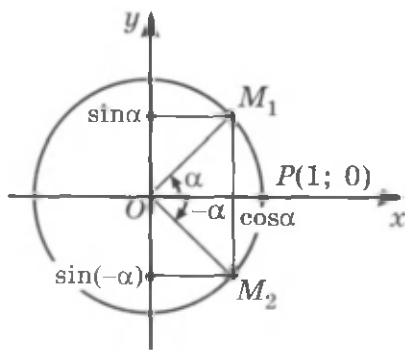

68- rasm.

**320.** Hisoblang:

1)  $\cos(-\frac{\pi}{6})\sin(-\frac{\pi}{3}) + \operatorname{tg}(-\frac{\pi}{4})$ ;      2)  $\frac{1+\operatorname{tg}^2(-30^\circ)}{1+\operatorname{ctg}^2(-30^\circ)}$ ;

3)  $2\sin(-\frac{\pi}{6})\cos(-\frac{\pi}{6}) + \operatorname{tg}(-\frac{\pi}{3}) + \sin^2(-\frac{\pi}{4})$ ;

4)  $\cos(-\pi) + \operatorname{ctg}(-\frac{\pi}{2}) - \sin(-\frac{3}{2}\pi) + \operatorname{ctg}(-\frac{\pi}{4})$ .

**321.** Ifodani soddalashtiring:

1)  $\operatorname{tg}(-\alpha)\cos\alpha + \sin\alpha$ ;      2)  $\cos\alpha - \operatorname{ctg}\alpha(-\sin\alpha)$ ;

3)  $\frac{\cos(-\alpha)+\sin(-\alpha)}{\cos^2\alpha-\sin^2\alpha}$ ;      4)  $\operatorname{tg}(-\alpha)\operatorname{ctg}(-\alpha) + \cos^2(-\alpha) + \sin^2\alpha$ .

**322.** Ayniyatni isbotlang:  $\frac{\cos^2\alpha-\sin^2\alpha}{\cos\alpha+\sin(-\alpha)} + \operatorname{tg}(-\alpha)\cos(-\alpha) = \cos\alpha$ .

**323.** Hisoblang:

1)  $\frac{3-\sin^2(-\frac{\pi}{3})-\cos^2(-\frac{\pi}{3})}{2\cos(-\frac{\pi}{4})}$ ;

2)  $2\sin(-\frac{\pi}{6}) - 3\operatorname{ctg}(-\frac{\pi}{4}) + 7,5\operatorname{tg}(-\pi) + \frac{1}{8}\cos(-\frac{3}{2}\pi)$ .

**324.** Soddalashtiring:

1)  $\frac{\sin^3(-\alpha)+\cos^3(-\alpha)}{1-\sin(-\alpha)\cos(-\alpha)}$ ;      2)  $\frac{1-(\sin\alpha+\cos(-\alpha))^2}{-\sin(-\alpha)}$ .

*Qo'shish formulari* deb  $\cos(\alpha \pm \beta)$  va  $\sin(\alpha \pm \beta)$  larni  $\alpha$  va  $\beta$  burchaklarning sinus va kosinuslari orqali ifodalovchi formulalarga aytiladi.

**Teorema.** Ixtiyoriy  $\alpha$  va  $\beta$  uchun quyidagi tenglik o'rinli bo'ladi:

$$\cos(\alpha + \beta) = \cos\alpha\cos\beta - \sin\alpha\sin\beta. \quad (1)$$

○  $M_0(1; 0)$  nuqtani koordinatalar boshi atrofida  $\alpha$ ,  $-\beta$ ,  $\alpha + \beta$  radian burchaklarga burish natijasida mos ravishda  $M_\alpha$ ,  $M_{-\beta}$  va  $M_{\alpha+\beta}$  nuqtalar hosil bo'ladi, deylik (69- rasm).

Sinus va kosinusning ta'rifiga ko'ra, bu nuqtalar quyidagi koordinatalarga ega:

$$M_\alpha(\cos\alpha; \sin\alpha), \quad M_{-\beta}(\cos(-\beta); \sin(-\beta)), \\ M_{\alpha+\beta}(\cos(\alpha + \beta); \sin(\alpha + \beta)).$$

$\angle M_0OM_{\alpha+\beta} = \angle M_{-\beta}OM_\alpha$  bo'lgani uchun  $M_0OM_{\alpha+\beta}$  va  $M_{-\beta}OM_\alpha$  teng yonli uchburchaklar teng va, demak, ularning  $M_0M_{\alpha+\beta}$  va  $M_{-\beta}M_\alpha$  asoslari ham teng. Shuning uchun

$$(M_0M_{\alpha+\beta})^2 = (M_{-\beta}M_\alpha)^2.$$

Geometriya kursidan ma'lum bo'lgan ikki nuqta orasidagi masofa formulasidan foydalanib, hosil qilamiz:

$$(1 - \cos(\alpha + \beta))^2 + (\sin(\alpha + \beta))^2 = (\cos(-\beta) - \cos\alpha)^2 + (\sin(-\beta) - \sin\alpha)^2.$$

25- § dagi (1) formuladan foydalanib, bu tenglikning shaklini almash-tiramiz:

$$1 - 2\cos(\alpha + \beta) + \cos^2(\alpha + \beta) + \sin^2(\alpha + \beta) = \\ = \cos^2\beta - 2\cos\beta\cos\alpha + \cos^2\alpha + \sin^2\beta + 2\sin\beta\sin\alpha + \sin^2\alpha.$$

Asosiy trigonometrik ayniyatdan foydalanib, hosil qilamiz:

$$2 - 2\cos(\alpha + \beta) = 2 - 2\cos\alpha\cos\beta + 2\sin\alpha\sin\beta,$$

bundan  $\cos(\alpha + \beta) = \cos\alpha\cos\beta - \sin\alpha\sin\beta$ . ●

**1-masala.**  $\cos 75^\circ$  ni hisoblang.

△ (1) formula bo'yicha topamiz:

$$\cos 75^\circ = \cos(45^\circ + 30^\circ) = \\ = \cos 45^\circ \cos 30^\circ - \sin 45^\circ \sin 30^\circ = \\ = \frac{\sqrt{2}}{2} \cdot \frac{\sqrt{3}}{2} - \frac{\sqrt{2}}{2} \cdot \frac{1}{2} = \frac{\sqrt{6} - \sqrt{2}}{4}. \blacktriangle$$

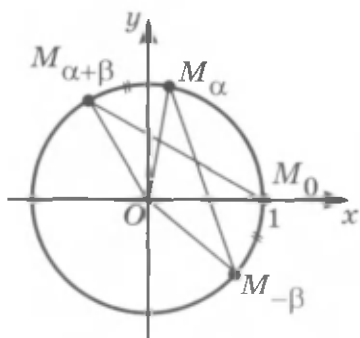

69- rasm.

(1) formulada  $\beta$  ni  $-\beta$  ga almashtirib, hosil qilamiz:

$$\cos(\alpha - \beta) = \cos\alpha\cos(-\beta) - \sin\alpha\sin(-\beta),$$

bundan



$$\cos(\alpha - \beta) = \cos\alpha\cos\beta + \sin\alpha\sin\beta. \quad (2)$$

**2-masala.**  $\cos 15^\circ$  ni hisoblang.

$\triangle$  (2) formulaga ko'ra, hosil qilamiz:

$$\begin{aligned} \cos 15^\circ &= \cos(45^\circ - 30^\circ) = \cos 45^\circ \cos 30^\circ + \sin 45^\circ \sin 30^\circ = \\ &= \frac{\sqrt{2}}{2} \cdot \frac{\sqrt{3}}{2} + \frac{\sqrt{2}}{2} \cdot \frac{1}{2} = \frac{\sqrt{6} + \sqrt{2}}{4}. \quad \blacktriangle \end{aligned}$$

**3-masala.** Ushbu formulalarni isbotlang:

$$\cos\left(\frac{\pi}{2} - \alpha\right) = \sin \alpha, \quad \sin\left(\frac{\pi}{2} - \alpha\right) = \cos \alpha. \quad (3)$$

$\triangle$   $\alpha = \frac{\pi}{2}$  bo'lganda (2) formulaga asosan:

$$\cos\left(\frac{\pi}{2} - \beta\right) = \cos \frac{\pi}{2} \cos \beta + \sin \frac{\pi}{2} \sin \beta = \sin \beta,$$

ya'ni

$$\cos\left(\frac{\pi}{2} - \beta\right) = \sin \beta. \quad (4)$$

Bu formulada  $\beta$  ni  $\alpha$  ga almashtirib, hosil qilamiz:

$$\cos\left(\frac{\pi}{2} - \alpha\right) = \sin \alpha.$$

(4) formulada  $\beta = \frac{\pi}{2} - \alpha$  deb faraz qilsak:

$$\sin\left(\frac{\pi}{2} - \alpha\right) = \cos \alpha. \quad \blacktriangle$$

(1)—(4) formulalardan foydalanib, *sinus uchun qo'shish formulasini* keltirib chiqaramiz:

$$\begin{aligned} \sin(\alpha + \beta) &= \cos\left(\frac{\pi}{2} - (\alpha + \beta)\right) = \cos\left(\left(\frac{\pi}{2} - \alpha\right) - \beta\right) = \\ &= \cos\left(\frac{\pi}{2} - \alpha\right) \cos \beta + \sin\left(\frac{\pi}{2} - \alpha\right) \sin \beta = \sin \alpha \cos \beta + \cos \alpha \sin \beta. \end{aligned}$$

Shunday qilib,



$$\sin(\alpha + \beta) = \sin\alpha\cos\beta + \cos\alpha\sin\beta. \quad (5)$$

(5) formulada  $\beta$  ni  $-\beta$  ga almashtirib, hosil qilamiz:

$$\sin(\alpha - \beta) = \sin\alpha\cos(-\beta) + \cos\alpha\sin(-\beta),$$

bundan



$$\sin(\alpha - \beta) = \sin\alpha\cos\beta - \cos\alpha\sin\beta. \quad (6)$$

**4-masala.**  $\sin 210^\circ$  ni hisoblang.

$$\triangle \sin 210^\circ = \sin(180^\circ + 30^\circ) =$$

$$= \sin 180^\circ \cos 30^\circ + \cos 180^\circ \sin 30^\circ = 0 \cdot \frac{\sqrt{3}}{2} + (-1) \cdot \frac{1}{2} = -\frac{1}{2}. \blacktriangle$$

**5-masala.** Hisoblang:

$$\sin \frac{8\pi}{7} \cos \frac{\pi}{7} - \sin \frac{\pi}{7} \cos \frac{8\pi}{7}.$$

$$\triangle \sin \frac{8\pi}{7} \cos \frac{\pi}{7} - \sin \frac{\pi}{7} \cos \frac{8\pi}{7} = \sin\left(\frac{8\pi}{7} - \frac{\pi}{7}\right) = \sin \pi = 0. \blacktriangle$$

**6-masala.** Tenglikni isbotlang:

$$\operatorname{tg}(\alpha + \beta) = \frac{\operatorname{tg}\alpha + \operatorname{tg}\beta}{1 - \operatorname{tg}\alpha \operatorname{tg}\beta}. \quad (7)$$

$$\triangle \operatorname{tg}(\alpha + \beta) = \frac{\sin(\alpha + \beta)}{\cos(\alpha + \beta)} = \frac{\sin\alpha \cos\beta + \cos\alpha \sin\beta}{\cos\alpha \cos\beta - \sin\alpha \sin\beta}.$$

Bu kasrning surat va maxrajini  $\cos\alpha\cos\beta$  ga bo'lib, (7) formulani hosil qilamiz.  $\blacktriangle$

(7) formula hisoblashlarda foydali bo'lishi mumkin.

Masalan, shu formula bo'yicha topamiz:

$$\operatorname{tg} 225^\circ = \operatorname{tg}(180^\circ + 45^\circ) = \frac{\operatorname{tg} 180^\circ + \operatorname{tg} 45^\circ}{1 - \operatorname{tg} 180^\circ \operatorname{tg} 45^\circ} = 1.$$

## Mashqlar

Qo'shish formulalari yordamida hisoblang (325–326):

**325.** 1)  $\cos 135^\circ$ ; 2)  $\cos 120^\circ$ ; 3)  $\cos 150^\circ$ ; 4)  $\cos 240^\circ$ .

**326.** 1)  $\cos 57^\circ 30' \cos 27^\circ 30' + \sin 57^\circ 30' \sin 27^\circ 30'$ ;

2)  $\cos 19^\circ 30' \cos 25^\circ 30' - \sin 19^\circ 30' \sin 25^\circ 30'$ ;

3)  $\cos \frac{7\pi}{9} \cos \frac{11\pi}{9} - \sin \frac{7\pi}{9} \sin \frac{11\pi}{9}$ ;      4)  $\cos \frac{8\pi}{7} \cos \frac{\pi}{7} + \sin \frac{8\pi}{7} \sin \frac{\pi}{7}$ .

- 327.** 1)  $\cos\left(\frac{\pi}{3} + \alpha\right)$ , bunda  $\sin\alpha = \frac{1}{\sqrt{3}}$  va  $0 < \alpha < \frac{\pi}{2}$ ;  
 2)  $\cos\left(\alpha - \frac{\pi}{4}\right)$ , bunda  $\cos\alpha = -\frac{1}{3}$  va  $\frac{\pi}{2} < \alpha < \pi$ .

Ifodani soddalashtiring (**328–329**):

- 328.** 1)  $\cos 3\alpha \cos \alpha - \sin \alpha \sin 3\alpha$ ;                      2)  $\cos 5\beta \cos 2\beta + \sin 5\beta \sin 2\beta$ ;  
 3)  $\cos\left(\frac{\pi}{7} + \alpha\right) \cos\left(\frac{5\pi}{14} - \alpha\right) - \sin\left(\frac{\pi}{7} + \alpha\right) \sin\left(\frac{5\pi}{14} - \alpha\right)$ ;  
 4)  $\cos\left(\frac{7\pi}{5} + \alpha\right) \cos\left(\frac{2\pi}{5} + \alpha\right) + \sin\left(\frac{7\pi}{5} + \alpha\right) \sin\left(\frac{2\pi}{5} + \alpha\right)$ .

- 329.** 1)  $\cos(\alpha + \beta) + \cos\left(\frac{\pi}{2} - \alpha\right) \cos\left(\frac{\pi}{2} - \beta\right)$ ;  
 2)  $\sin\left(\frac{\pi}{2} - \alpha\right) \sin\left(\frac{\pi}{2} - \beta\right) - \cos(\alpha - \beta)$ .

Qo'shish formulalari yordamida hisoblang (**330–331**):

- 330.** 1)  $\sin 73^\circ \cos 17^\circ + \cos 73^\circ \sin 17^\circ$ ;  
 2)  $\sin 73^\circ \cos 13^\circ - \cos 73^\circ \sin 13^\circ$ ;  
 3)  $\sin \frac{5\pi}{12} \cos \frac{\pi}{12} + \sin \frac{\pi}{12} \cos \frac{5\pi}{12}$ ;                      4)  $\sin \frac{7\pi}{12} \cos \frac{\pi}{12} - \sin \frac{\pi}{12} \cos \frac{7\pi}{12}$ .

- 331.** 1)  $\sin\left(\alpha + \frac{\pi}{6}\right)$ , bunda  $\cos\alpha = -\frac{3}{5}$  va  $\pi < \alpha < \frac{3\pi}{2}$ ;  
 2)  $\sin\left(\frac{\pi}{4} - \alpha\right)$ , bunda  $\sin\alpha = \frac{\sqrt{2}}{3}$  va  $\frac{\pi}{2} < \alpha < \pi$ .

**332.** Ifodani soddalashtiring:

- 1)  $\sin(\alpha + \beta) + \sin(-\alpha)\cos(-\beta)$ ;                      2)  $\cos(-\alpha)\sin(-\beta) - \sin(\alpha - \beta)$ ;  
 3)  $\cos\left(\frac{\pi}{2} - \alpha\right) \sin\left(\frac{\pi}{2} - \beta\right) - \sin(\alpha - \beta)$ ;  
 4)  $\sin(\alpha + \beta) + \sin\left(\frac{\pi}{2} - \alpha\right) \sin(-\beta)$ .

- 333.** Agar  $\sin\alpha = -\frac{3}{5}$ ,  $\frac{3}{2}\pi < \alpha < 2\pi$  va  $\sin\beta = \frac{8}{17}$ ,  $0 < \beta < \frac{\pi}{2}$  bo'lsa,  $\cos(\alpha + \beta)$  va  $\cos(\alpha - \beta)$  ni hisoblang.



334. Agar  $\cos \alpha = -0,8$ ,  $\frac{\pi}{2} < \alpha < \pi$  va  $\sin \beta = -\frac{12}{13}$ ,  $\pi < \beta < \frac{3\pi}{2}$  bo'lsa,  $\sin(\alpha - \beta)$  ni hisoblang.

335. Ifodani soddalashtiring:

$$1) \cos\left(\frac{2}{3}\pi - \alpha\right) + \cos\left(\alpha + \frac{\pi}{3}\right); \quad 2) \sin\left(\alpha + \frac{2}{3}\pi\right) - \sin\left(\frac{\pi}{3} - \alpha\right);$$

$$3) \frac{2 \cos \alpha \sin \beta + \sin(\alpha - \beta)}{2 \cos \alpha \cos \beta - \cos(\alpha - \beta)}; \quad 4) \frac{\cos \alpha \cos \beta - \cos(\alpha + \beta)}{\cos(\alpha - \beta) - \sin \alpha \sin \beta}.$$

336. Ayniyatni isbotlang:

$$1) \sin(\alpha - \beta) \sin(\alpha + \beta) = \sin^2 \alpha - \sin^2 \beta;$$

$$2) \cos(\alpha - \beta) \cos(\alpha + \beta) = \cos^2 \alpha - \sin^2 \beta;$$

$$3) \frac{\sqrt{2} \cos \alpha - 2 \cos\left(\frac{\pi}{4} - \alpha\right)}{2 \sin\left(\frac{\pi}{6} + \alpha\right) - \sqrt{3} \sin \alpha} = -\sqrt{2} \operatorname{tg} \alpha; \quad 4) \frac{\cos \alpha - 2 \cos\left(\frac{\pi}{3} + \alpha\right)}{2 \sin\left(\alpha - \frac{\pi}{6}\right) - \sqrt{3} \sin \alpha} = -\sqrt{3} \operatorname{tg} \alpha.$$

337. Ifodani soddalashtiring: 1)  $\frac{\operatorname{tg} 29^\circ + \operatorname{tg} 31^\circ}{1 - \operatorname{tg} 29^\circ \operatorname{tg} 31^\circ}$ ; 2)  $\frac{\operatorname{tg} \frac{7}{16}\pi - \operatorname{tg} \frac{3}{16}\pi}{1 + \operatorname{tg} \frac{7}{16}\pi \operatorname{tg} \frac{3}{16}\pi}$ .

## 27- §.

### IKKILANGAN BURCHAKNING SINUSI VA KOSINUSI

Qo'shish formulalaridan foydalanib, *ikkilangan burchakning sinusi va kosinusi formulalarini* keltirib chiqaramiz.

$$1) \sin 2\alpha = \sin(\alpha + \alpha) = \sin \alpha \cos \alpha + \sin \alpha \cos \alpha = 2 \sin \alpha \cos \alpha.$$

Shunday qilib,

$$\sin 2\alpha = 2 \sin \alpha \cos \alpha. \quad (1)$$

**1- masala.** Agar  $\sin \alpha = -0,6$  va  $\pi < \alpha < \frac{3\pi}{2}$  bo'lsa,  $\sin 2\alpha$  ni hisoblang.

$\triangle$  (1) formula bo'yicha topamiz:

$$\sin 2\alpha = 2 \sin \alpha \cos \alpha = 2 \cdot (-0,6) \cdot \cos \alpha = -1,2 \cos \alpha.$$

$\pi < \alpha < \frac{3\pi}{2}$  bo'lgani uchun  $\cos \alpha < 0$  bo'ladi va shuning uchun:

$$\cos \alpha = -\sqrt{1 - \sin^2 \alpha} = -\sqrt{1 - 0,36} = -0,8.$$

Demak,  $\sin 2\alpha = -1,2 \cdot (-0,8) = 0,96$ .  $\blacktriangle$

2)  $\cos 2\alpha = \cos(\alpha + \alpha) = \cos\alpha\cos\alpha - \sin\alpha\sin\alpha = \cos^2\alpha - \sin^2\alpha$ .  
Shunday qilib,



$$\cos 2\alpha = \cos^2\alpha - \sin^2\alpha. \quad (2)$$

**2- masala.** Agar  $\cos\alpha = 0,3$  bo'lsa,  $\cos 2\alpha$  ni hisoblang.

$\Delta$  (2) formuladan va asosiy trigonometrik ayniyatdan foydalanib, hosil qilamiz:

$$\begin{aligned} \cos 2\alpha &= \cos^2\alpha - \sin^2\alpha = \cos^2\alpha - (1 - \cos^2\alpha) = \\ &= 2\cos^2\alpha - 1 = 2 \cdot (0,3)^2 - 1 = -0,82. \quad \blacktriangle \end{aligned}$$

**3- masala.** Ifodani soddalashtiring:  $\frac{\sin\alpha\cos\alpha}{1-2\sin^2\alpha}$ .

$$\begin{aligned} \Delta \frac{\sin\alpha\cos\alpha}{1-2\sin^2\alpha} &= \frac{2\sin\alpha\cos\alpha}{2(\sin^2\alpha + \cos^2\alpha) - 2\sin^2\alpha} = \frac{\sin 2\alpha}{2(\cos^2\alpha - \sin^2\alpha)} = \\ &= \frac{\sin 2\alpha}{2\cos 2\alpha} = \frac{1}{2} \operatorname{tg} 2\alpha. \quad \blacktriangle \end{aligned}$$

**4- masala.** Agar  $\operatorname{tg}\alpha = \frac{1}{2}$  bo'lsa,  $\operatorname{tg} 2\alpha$  ni hisoblang.

$$\Delta \operatorname{tg}(\alpha + \beta) = \frac{\operatorname{tg}\alpha + \operatorname{tg}\beta}{1 - \operatorname{tg}\alpha\operatorname{tg}\beta}$$

formulada  $\beta = \alpha$  deb faraz qilib (26-§ ga qarang), hosil qilamiz:

$$\operatorname{tg} 2\alpha = \frac{2\operatorname{tg}\alpha}{1 - \operatorname{tg}^2\alpha}. \quad (3)$$

Agar  $\operatorname{tg}\alpha = \frac{1}{2}$  bo'lsa, u holda (3) formula bo'yicha topamiz:

$$\operatorname{tg} 2\alpha = \frac{2 \cdot \frac{1}{2}}{1 - \left(\frac{1}{2}\right)^2} = \frac{4}{3}. \quad \blacktriangle$$

### **Mashqlar**

Hisoblang (338–339):

338. 1)  $2\sin 15^\circ \cos 15^\circ$ ;

2)  $\cos^2 15^\circ - \sin^2 15^\circ$ ;

3)  $(\cos 75^\circ - \sin 75^\circ)^2$ ;

4)  $(\cos 15^\circ + \sin 15^\circ)^2$ .

339. 1)  $2 \sin \frac{\pi}{8} \cos \frac{\pi}{8}$ ;

2)  $\cos^2 \frac{\pi}{8} - \sin^2 \frac{\pi}{8}$ ;

3)  $\sin \frac{\pi}{8} \cos \frac{\pi}{8} + \frac{1}{4}$ ;

4)  $\frac{\sqrt{2}}{2} - \left( \cos \frac{\pi}{8} + \sin \frac{\pi}{8} \right)^2$ .

340. Agar:

1)  $\sin \alpha = \frac{3}{5}$  va  $\frac{\pi}{2} < \alpha < \pi$ ;

2)  $\cos \alpha = -\frac{4}{5}$  va  $\pi < \alpha < \frac{3\pi}{2}$

bo'lsa,  $\sin 2\alpha$  ni hisoblang.

341. Agar:

1)  $\cos \alpha = \frac{4}{5}$ ;      2)  $\sin \alpha = -\frac{3}{5}$  bo'lsa,  $\cos 2\alpha$  ni hisoblang.

Ifodani soddalashtiring (342–343):

342. 1)  $\sin \alpha \cos \alpha$ ;

2)  $\cos \alpha \cos \left( \frac{\pi}{2} - \alpha \right)$ ;

3)  $\cos 4\alpha + \sin^2 2\alpha$ ;

4)  $\sin 2\alpha + (\sin \alpha - \cos \alpha)^2$ .

343. 1)  $\frac{\cos 2\alpha + 1}{2 \cos \alpha}$ ;      2)  $\frac{\sin 2\alpha}{1 - \cos^2 \alpha}$ ;      3)  $\frac{\sin^2 \alpha}{(\sin \alpha + \cos \alpha)^2 - 1}$ ;      4)  $\frac{1 + \cos 2\alpha}{1 - \cos 2\alpha}$ .

344. Ayniyatni isbotlang:

1)  $\sin 2\alpha = (\sin \alpha + \cos \alpha)^2 - 1$ ;      2)  $(\sin \alpha - \cos \alpha)^2 = 1 - \sin 2\alpha$ ;

3)  $\cos^4 \alpha - \sin^4 \alpha = \cos 2\alpha$ ;      4)  $2 \cos^2 \alpha - \cos 2\alpha = 1$ .

345. Agar:

1)  $\sin \alpha + \cos \alpha = \frac{1}{2}$ ;

2)  $\sin \alpha - \cos \alpha = -\frac{1}{3}$

bo'lsa,  $\sin 2\alpha$  ni hisoblang.

346. Ayniyatni isbotlang:

1)  $1 + \cos 2\alpha = 2 \cos^2 \alpha$ ;

2)  $1 - \cos 2\alpha = 2 \sin^2 \alpha$ .

347. Hisoblang:

1)  $2 \cos^2 15^\circ - 1$ ;

2)  $1 - 2 \sin^2 22,5^\circ$ ;

3)  $2 \cos^2 \frac{\pi}{8} - 1$ ;

4)  $1 - 2 \sin^2 \frac{\pi}{12}$ .

348. Ifodani soddalashtiring:

1)  $1 - 2 \sin^2 5\alpha$ ;

2)  $2 \cos^2 3\alpha - 1$ ;

3)  $\frac{1 - \cos 2\alpha}{\sin \frac{\alpha}{2} \cos \frac{\alpha}{2}}$ ;

4)  $\frac{2 \cos^2 \frac{\alpha}{2} - 1}{\sin 2\alpha}$ .

349. Ayniyatni isbotlang:

$$1) \frac{\cos 2\alpha}{\sin \alpha \cos \alpha + \sin^3 \alpha} = \operatorname{ctg} \alpha - 1; \quad 2) \frac{\sin 2\alpha - 2 \cos \alpha}{\sin \alpha - \sin^3 \alpha} = -2 \operatorname{ctg} \alpha;$$

$$3) \operatorname{tg} \alpha (1 + \cos 2\alpha) = \sin 2\alpha; \quad 4) \frac{1 - \cos 2\alpha + \sin 2\alpha}{1 + \cos 2\alpha + \sin 2\alpha} \cdot \operatorname{ctg} \alpha = 1.$$

350. Agar  $\operatorname{tg} \alpha = 0,6$  bo'lsa,  $\operatorname{tg} 2\alpha$  ni hisoblang.

351. Hisoblang: 1)  $\frac{2 \operatorname{tg} \frac{\pi}{8}}{1 - \operatorname{tg}^2 \frac{\pi}{8}}$ ; 2)  $\frac{6 \operatorname{tg} 15^\circ}{1 - \operatorname{tg}^2 15^\circ}$ .

## 28- §.

## KELTIRISH FORMULALARI

Sinus, kosinus, tangens va kotangens qiymatlarining jadvallari  $0^\circ$  dan  $90^\circ$  gacha (yoki 0 dan  $\frac{\pi}{2}$  gacha) burchaklar uchun tuziladi. Bu hol ularning boshqa burchaklar uchun qiymatlari o'tkir burchaklar uchun qiymatlariga keltirilishi bilan izohlanadi.

**1- masala.**  $\sin 870^\circ$  va  $\cos 870^\circ$  ni hisoblang.

$\triangle 870^\circ = 2 \cdot 360^\circ + 150^\circ$ . Shuning uchun  $P(1; 0)$  nuqtani koordinatlar boshi atrofida  $870^\circ$  ga burganda nuqta ikkita to'la aylanishni bajaradi va yana  $150^\circ$  burchakka buriladi, ya'ni  $150^\circ$  ga burishdagi  $M$  nuqtaning xuddi o'zi hosil bo'ladi (70- rasm). Shuning uchun  $\sin 870^\circ = \sin 150^\circ$ ,  $\cos 870^\circ = \cos 150^\circ$ .

$M$  nuqtaga  $Oy$  o'qqa nisbatan simmetrik bo'lgan  $M_1$  nuqtani yasaymiz (71- rasm).  $M$  va  $M_1$  nuqtalarning ordinatalari bir xil, absissalari esa faqat ishoralari bilan farq qiladi. Shuning uchun  $\sin 150^\circ = \sin 30^\circ = \frac{1}{2}$ ;  $\cos 150^\circ = -\cos 30^\circ = -\frac{\sqrt{3}}{2}$ .

**J a v o b:**  $\sin 870^\circ = \frac{1}{2}$ ,  $\cos 870^\circ = -\frac{\sqrt{3}}{2}$ . ▲

1- masalani yechishda

$$\sin(2 \cdot 360^\circ + 150^\circ) = \sin 150^\circ, \quad \cos(2 \cdot 360^\circ + 150^\circ) = \cos 150^\circ, \quad (1)$$

$$\sin(180^\circ - 30^\circ) = \sin 30^\circ, \quad \cos(180^\circ - 30^\circ) = -\cos 30^\circ \quad (2)$$

tengliklardan foydalanildi.

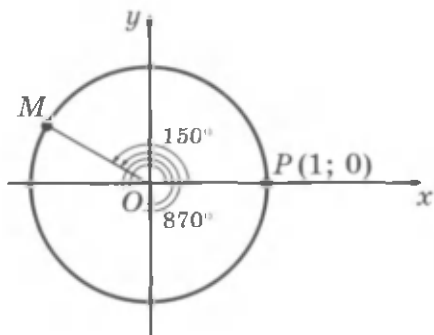

70- rasm.

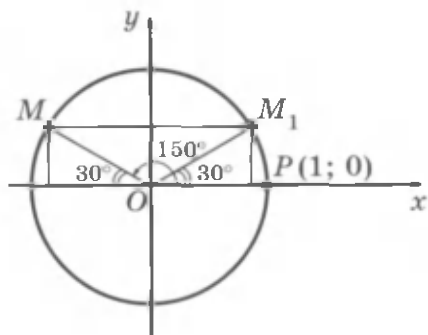

71- rasm.

(1) tenglik to'g'ri tenglik, chunki  $P(1; 0)$  nuqtani  $\alpha + 2\pi k$ ,  $k \in \mathbb{Z}$  bur-chakka burganda uni  $\alpha$  burchakka burgandagi nuqtaning ayni o'zi hosil bo'ladi.

Shuning uchun ushbu formulalar to'g'ri bo'ladi:

! 
$$\sin(\alpha + 2\pi k) = \sin\alpha, \cos(\alpha + 2\pi k) = \cos\alpha, k \in \mathbb{Z}. \quad (3)$$

Xususan,  $k = 1$  bo'lganda:

$$\sin(\alpha + 2\pi) = \sin\alpha, \cos(\alpha + 2\pi) = \cos\alpha$$

tengliklar o'rinlidir.

(2) tenglik

! 
$$\sin(\pi - \alpha) = \sin\alpha, \cos(\pi - \alpha) = -\cos\alpha \quad (4)$$

formulalarning xususiy holi sanaladi.

$\sin(\pi - \alpha) = \sin\alpha$  formulani isbot qilamiz.

○ Sinus uchun qo'shish formulasini qo'llab, hosil qilamiz:

$$\sin(\pi - \alpha) = \sin\pi \cos\alpha - \cos\pi \sin\alpha =$$

$$= 0 \cdot \cos\alpha - (-1) \cdot \sin\alpha = \sin\alpha. \quad \bullet$$

(4) formulalarning ikkinchisi ham shunga o'xshash isbot qilinadi. (4) formulalar *keltirish formulalari* deyiladi. (3) va (4) formulalar yordamida istalgan burchakning sinus va kosinusini hisoblashni ularning o'tkir burchak uchun qiymatlarini hisoblashga keltirish mumkin.

**2-masala.**  $\sin 930^\circ$  ni hisoblang.

$\triangle$  (3) formuladan foydalanib, hosil qilamiz:

$$\sin 930^\circ = \sin(3 \cdot 360^\circ - 150^\circ) = \sin(-150^\circ).$$

$\sin(-\alpha) = -\sin\alpha$  formula bo'yicha  $\sin(-150^\circ) = -\sin 150^\circ$  ni hosil qilamiz.

(4) formula bo'yicha topamiz:

$$-\sin 150^\circ = -\sin(180^\circ - 30^\circ) = -\sin 30^\circ = -\frac{1}{2}.$$

**Javob:**  $\sin 930^\circ = -\frac{1}{2}$ .  $\blacktriangle$

**3-masala.**  $\cos \frac{15\pi}{4}$  ni hisoblang.

$$\triangle \cos \frac{15\pi}{4} = \cos(4\pi - \frac{\pi}{4}) = \cos(-\frac{\pi}{4}) = \cos \frac{\pi}{4} = \frac{\sqrt{2}}{2}. \blacktriangle$$

Endi istalgan burchakning tangensini hisoblashni o'tkir burchakning tangensini hisoblashga qanday keltirish mumkinligini ko'rsatamiz.

(3) formuladan va tangensning ta'rifidan

$$\operatorname{tg}(\alpha + 2\pi k) = \operatorname{tg} \alpha, \quad k \in \mathbf{Z}$$

tenglik kelib chiqadi.

Bu tenglik va (4) formuladan foydalanib, hosil qilamiz:

$$\begin{aligned} \operatorname{tg}(\alpha + \pi) &= \operatorname{tg}(\alpha + \pi - 2\pi) = \operatorname{tg}(\alpha - \pi) = -\operatorname{tg}(\pi - \alpha) = \\ &= -\frac{\sin(\pi - \alpha)}{\cos(\pi - \alpha)} = -\frac{\sin \alpha}{-\cos \alpha} = \operatorname{tg} \alpha. \end{aligned}$$

Shuning uchun ushbu formula o'rinli bo'ladi:



$$\operatorname{tg}(\alpha + \pi k) = \operatorname{tg} \alpha, \quad k \in \mathbf{Z}. \quad (5)$$

**4-masala.** Hisoblang: 1)  $\operatorname{tg} \frac{11\pi}{3}$ ; 2)  $\operatorname{tg} \frac{13\pi}{4}$ .

$$\triangle \quad 1) \operatorname{tg} \frac{11\pi}{3} = \operatorname{tg}(4\pi - \frac{\pi}{3}) = \operatorname{tg}(-\frac{\pi}{3}) = -\operatorname{tg} \frac{\pi}{3} = -\sqrt{3}.$$

$$2) \operatorname{tg} \frac{13\pi}{4} = \operatorname{tg}(3\pi + \frac{\pi}{4}) = \operatorname{tg} \frac{\pi}{4} = 1. \blacktriangle$$

$$\sin\left(\frac{\pi}{2} - \alpha\right) = \cos\alpha, \quad \cos\left(\frac{\pi}{2} - \alpha\right) = \sin\alpha$$

formulalar isbotlangan edi, ular ham *keltirish formulalari* deb ataladi. Bu formulalardan foydalanib, masalan,  $\sin\frac{\pi}{3} = \cos\frac{\pi}{6}$ ,  $\cos\frac{\pi}{3} = \sin\frac{\pi}{6}$  ni hosil qilamiz.

$x$  ning istalgan qiymati uchun  $\sin(x + 2\pi) = \sin x$ ,  $\cos(x + 2\pi) = \cos x$  tengliklar to'g'riligi ma'lum.

Bu tengliklardan ko'rinadiki, argument  $2\pi$  ga o'zgarganda sinus va kosinusning qiymatlari davriy takrorlanadi. Bunday funksiyalar *davri  $2\pi$  bo'lgan davriy funksiyalar* deyiladi.

**Agar shunday  $T \neq 0$  son mavjud bo'lsaki,  $y = f(x)$  funksiya-ning aniqlanish sohasidagi istalgan  $x$  uchun**

$$f(x - T) = f(x) = f(x + T)$$

**tenglik bajarilsa,  $f(x)$  davriy funksiya deb ataladi.**

**$T$  son  $f(x)$  funksiyaning davri deyiladi.**

Bu ta'rifdan ko'rinadiki, agar  $x$  son  $f(x)$  funksiyaning aniqlanish sohasiga tegishli bo'lsa, u holda  $x + T$ ,  $x - T$  sonlar va, umuman,  $x + Tn$ ,  $n \in \mathbb{Z}$  sonlar ham shu davriy funksiyaning aniqlanish sohasiga tegishli va  $f(x + Tn) = f(x)$ ,  $n \in \mathbb{Z}$  bo'ladi.

$2\pi$  soni  $y = \cos x$  funksiyaning eng kichik musbat davri ekanini ko'rsatamiz.

○  $T > 0$  kosinusning davri bo'lsin, ya'ni istalgan  $x$  uchun  $\cos(x + T) = \cos x$  tenglik bajariladi.  $x = 0$  deb,  $\cos T = 1$  ni hosil qilamiz. Bundan esa  $T = 2\pi k$ ,  $k \in \mathbb{Z}$ .  $T > 0$  bo'lganidan  $T$  quyidagi  $2\pi$ ,  $4\pi$ ,  $6\pi$ , ... qiymatlarni qabul qila oladi va shuning uchun  $T$  ning qiymati  $2\pi$  dan kichik bo'lishi mumkin emas. ●

$y = \sin x$  funksiyaning eng kichik musbat davri ham  $2\pi$  ga teng ekanini isbotlash mumkin.

Hisoblang (352–355):

352. 1)  $\sin \frac{13}{2} \pi$ ;                      2)  $\sin 17\pi$ ;                      3)  $\cos 7\pi$ ;  
 4)  $\cos \frac{11}{2} \pi$ ;                      5)  $\sin 720^\circ$ ;                      6)  $\cos 540^\circ$ .  
 353. 1)  $\cos 420^\circ$ ;                      2)  $\operatorname{tg} 570^\circ$ ;                      3)  $\sin 3630^\circ$ ;  
 4)  $\operatorname{ctg} 960^\circ$ ;                      5)  $\sin \frac{13\pi}{6}$ ;                      6)  $\operatorname{tg} \frac{11}{6} \pi$ .  
 354. 1)  $\cos 150^\circ$ ;                      2)  $\sin 135^\circ$ ;                      3)  $\cos 120^\circ$ ;                      4)  $\sin 315^\circ$ .  
 355. 1)  $\operatorname{tg} \frac{5\pi}{4}$ ;                      2)  $\sin \frac{7\pi}{6}$ ;                      3)  $\cos \frac{5\pi}{3}$ ;  
 4)  $\sin\left(-\frac{11\pi}{6}\right)$ ;                      5)  $\cos\left(-\frac{7\pi}{3}\right)$ ;                      6)  $\operatorname{tg}\left(-\frac{2\pi}{3}\right)$ .

356. Ifodaning son qiymatini toping:

- 1)  $\cos 630^\circ - \sin 1470^\circ - \operatorname{ctg} 1125^\circ$ ;  
 2)  $\operatorname{tg} 1800^\circ - \sin 495^\circ + \cos 945^\circ$ ;  
 3)  $\sin(-7\pi) - 2 \cos \frac{31\pi}{3} - \operatorname{tg} \frac{7\pi}{4}$ ;  
 4)  $\cos(-9\pi) + 2 \sin\left(-\frac{49\pi}{6}\right) - \operatorname{ctg}\left(-\frac{21\pi}{4}\right)$ .

357. Ifodani soddalashtiring:

- 1)  $\cos^2(\pi - \alpha) + \sin^2(\alpha - \pi)$ ;  
 2)  $\cos(\pi - \alpha)\cos(3\pi - \alpha) - \sin(\alpha - \pi)\sin(\alpha - 3\pi)$ .

358. Hisoblang:

- 1)  $\cos 7230^\circ + \sin 900^\circ$ ;                      2)  $\sin 300^\circ + \operatorname{tg} 150^\circ$ ;  
 3)  $2 \sin 6,5\pi - \sqrt{3} \sin \frac{19\pi}{3}$ ;                      4)  $\sqrt{2} \cos 4,25\pi - \frac{1}{\sqrt{3}} \cos \frac{61\pi}{6}$ ;  
 5)  $\frac{\sin(-6,5\pi) + \operatorname{tg}(-7\pi)}{\cos(-7\pi) + \operatorname{ctg}(-16,25\pi)}$ ;                      6)  $\frac{\cos(-540^\circ) + \sin 480^\circ}{\operatorname{tg} 405^\circ - \operatorname{ctg} 330^\circ}$ .



359. Ifodani soddalashtiring:

$$1) \frac{\sin\left(\frac{\pi}{2}-\alpha\right)+\sin(\pi-\alpha)}{\cos(\pi-\alpha)+\sin(2\pi-\alpha)};$$

$$2) \frac{\cos(\pi-\alpha)+\cos\left(\frac{\pi}{2}-\alpha\right)}{\sin(\pi-\alpha)-\sin\left(\frac{\pi}{2}-\alpha\right)};$$

$$3) \frac{\sin(\alpha-\pi)}{\operatorname{tg}(\alpha+\pi)} \cdot \frac{\operatorname{tg}(\pi-\alpha)}{\cos\left(\frac{\pi}{2}-\alpha\right)};$$

$$4) \frac{\sin^2(\pi-\alpha)+\sin^2\left(\frac{\pi}{2}-\alpha\right)}{\sin(\pi-\alpha)} \cdot \operatorname{tg}(\pi-\alpha).$$

360. Uchburchakning ikkita ichki burchagi yig'indisining sinusi uchinchil burchagining sinusiga tengligini isbotlang.

361. Ayniyatni isbotlang:

$$1) \sin\left(\frac{\pi}{2}+\alpha\right) = \cos \alpha;$$

$$2) \cos\left(\frac{\pi}{2}+\alpha\right) = -\sin \alpha;$$

$$3) \cos\left(\frac{3}{2}\pi-\alpha\right) = -\sin \alpha;$$

$$4) \sin\left(\frac{3}{2}\pi-\alpha\right) = -\cos \alpha.$$

362. Tenglamani yeching:

$$1) \cos\left(\frac{\pi}{2}-x\right) = 1;$$

$$2) \sin(\pi-x) = 1;$$

$$3) \cos(x-\pi) = 0;$$

$$4) \sin\left(x-\frac{\pi}{2}\right) = 1.$$

## 29- §.

### SINUSLAR YIG'INDISI VA AYIRMASI. KOSINUSLAR YIG'INDISI VA AYIRMASI

1 - masala. Ifodani soddalashtiring:

$$\left(\sin\left(\alpha+\frac{\pi}{12}\right)+\sin\left(\alpha-\frac{\pi}{12}\right)\right)\sin\frac{\pi}{12}.$$

△ Qo'shish formulasi va ikkilangan burchak sinusi formulasidan foydalanib, quyidagiga ega bo'lamiz:

$$\begin{aligned} & \left(\sin\left(\alpha+\frac{\pi}{12}\right)+\sin\left(\alpha-\frac{\pi}{12}\right)\right)\sin\frac{\pi}{12} = \\ & = \left(\sin\alpha\cos\frac{\pi}{12}+\cos\alpha\sin\frac{\pi}{12}+\sin\alpha\cos\frac{\pi}{12}-\cos\alpha\sin\frac{\pi}{12}\right)\sin\frac{\pi}{12} = \\ & = 2\sin\alpha\cos\frac{\pi}{12}\cdot\sin\frac{\pi}{12} = \sin\alpha\sin\frac{\pi}{6} = \frac{1}{2}\sin\alpha. \blacktriangle \end{aligned}$$

Agar sinuslar yig'indisi formulasi

$$\sin \alpha + \sin \beta = 2 \sin \frac{\alpha + \beta}{2} \cos \frac{\alpha - \beta}{2} \quad (1)$$

dan foydalanilsa, bu masalani soddaroq yechish mumkin. Shu formula yordamida quyidagini hosil qilamiz:

$$\begin{aligned} & \left( \sin\left(\alpha + \frac{\pi}{12}\right) + \sin\left(\alpha - \frac{\pi}{12}\right) \right) \sin \frac{\pi}{12} = \\ & = 2 \sin \alpha \cos \frac{\pi}{12} \cdot \sin \frac{\pi}{12} = \frac{1}{2} \sin \alpha . \end{aligned}$$

Endi (1) formulaning o'rinli ekanini isbotlaymiz.

○  $\frac{\alpha + \beta}{2} = x$ ,  $\frac{\alpha - \beta}{2} = y$  belgilash kiritamiz. U holda  $x + y = \alpha$ ,  $x - y = \beta$  va shuning uchun  $\sin \alpha + \sin \beta = \sin(x + y) + \sin(x - y) = \sin x \cos y + \cos x \sin y + \sin x \cos y - \cos x \sin y = 2 \sin x \cos y = 2 \sin \frac{\alpha + \beta}{2} \cos \frac{\alpha - \beta}{2}$ . ●

(1) formula bilan bir qatorda quyidagi *sinuslar ayirmasi formulasi*, *kosinuslar yig'indisi va ayirmasi formulalaridan* ham foydalaniladi:

$$\sin \alpha - \sin \beta = 2 \sin \frac{\alpha - \beta}{2} \cos \frac{\alpha + \beta}{2}, \quad (2)$$

$$\cos \alpha + \cos \beta = 2 \cos \frac{\alpha + \beta}{2} \cos \frac{\alpha - \beta}{2}, \quad (3)$$

$$\cos \alpha - \cos \beta = -2 \sin \frac{\alpha + \beta}{2} \sin \frac{\alpha - \beta}{2}. \quad (4)$$

(3) va (4) formulalar ham (1) formulaning isbotlanishiga o'xshash isbotlanadi; (2) formula  $\beta$  ni  $-\beta$  ga almashtirish bilan (1) formuladan hosil qilinadi (*buni mustaqil isbotlang*).

**2-masala.**  $\sin 75^\circ + \cos 75^\circ$  ni hisoblang.

$$\begin{aligned} & \triangle \sin 75^\circ + \cos 75^\circ = \sin 75^\circ + \sin 15^\circ = \\ & = 2 \sin \frac{75^\circ + 15^\circ}{2} \cos \frac{75^\circ - 15^\circ}{2} = 2 \sin 45^\circ \cos 30^\circ = 2 \frac{\sqrt{2}}{2} \cdot \frac{\sqrt{3}}{2} = \frac{\sqrt{6}}{2}. \blacktriangle \end{aligned}$$

**3-masala.**  $2\sin\alpha + \sqrt{3}$  ni ko'paytmaga almashtiring.

$$\begin{aligned}\Delta 2\sin\alpha + \sqrt{3} &= 2\left(\sin\alpha + \frac{\sqrt{3}}{2}\right) = 2\left(\sin\alpha + \sin\frac{\pi}{3}\right) = \\ &= 4\sin\left(\frac{\alpha}{2} + \frac{\pi}{6}\right)\cos\left(\frac{\alpha}{2} - \frac{\pi}{6}\right). \blacktriangle\end{aligned}$$

**4-masala.**  $\sin\alpha + \cos\alpha$  ifodaning eng kichik qiymati  $-\sqrt{2}$  ga, eng katta qiymati esa  $\sqrt{2}$  ga teng ekanini isbotlang.

$\Delta$  Berilgan ifodani ko'paytmaga almashtiramiz:

$$\sin\alpha + \cos\alpha = \sin\alpha + \sin\left(\frac{\pi}{2} - \alpha\right) = 2\sin\frac{\pi}{4}\cos\left(\alpha - \frac{\pi}{4}\right) = \sqrt{2}\cos\left(\alpha - \frac{\pi}{4}\right).$$

Kosinusning eng kichik qiymati  $-1$  ga, eng katta qiymati esa  $1$  ga teng bo'lgani uchun berilgan ifodaning eng kichik qiymati  $\sqrt{2} \cdot (-1) = -\sqrt{2}$  ga, eng katta qiymati esa  $\sqrt{2} \cdot 1 = \sqrt{2}$  ga teng.  $\blacktriangle$

### Mashqlar

**363.** Ifodani soddalashtiring:

- 1)  $\sin\left(\frac{\pi}{3} + \alpha\right) + \sin\left(\frac{\pi}{3} - \alpha\right)$ ; 2)  $\cos\left(\frac{\pi}{4} - \beta\right) - \cos\left(\frac{\pi}{4} + \beta\right)$ ;  
3)  $\sin^2\left(\frac{\pi}{4} + \alpha\right) - \sin^2\left(\frac{\pi}{4} - \alpha\right)$ ; 4)  $\cos^2\left(\alpha - \frac{\pi}{4}\right) - \cos^2\left(\alpha + \frac{\pi}{4}\right)$ .

**364.** Hisoblang:

- 1)  $\cos 105^\circ + \cos 75^\circ$ ; 2)  $\sin 105^\circ - \sin 75^\circ$ ;  
3)  $\cos \frac{11\pi}{12} + \cos \frac{5\pi}{12}$ ; 4)  $\cos \frac{11\pi}{12} - \cos \frac{5\pi}{12}$ ;  
5)  $\sin \frac{7\pi}{12} - \cos \frac{\pi}{12}$ ; 6)  $\sin 105^\circ + \sin 165^\circ$ .

**365.** Ko'paytmaga almashtiring:

- 1)  $1 + 2\sin\alpha$ ; 2)  $1 - 2\sin\alpha$ ;  
3)  $1 + 2\cos\alpha$ ; 4)  $1 + \sin\alpha$ ;

**366.** Ayniyatni isbotlang:

- 1)  $\frac{\sin\alpha + \sin 3\alpha}{\cos\alpha + \cos 3\alpha} = \operatorname{tg} 2\alpha$ ; 2)  $\frac{\sin 2\alpha + \sin 4\alpha}{\cos 2\alpha - \cos 4\alpha} = \operatorname{ctg} \alpha$ .

**367.** Ifodani soddalashtiring:

$$1) \frac{2(\cos \alpha + \cos 3\alpha)}{2 \sin 2\alpha + \sin 4\alpha}; \quad 2) \frac{1 + \sin \alpha - \cos 2\alpha - \sin 3\alpha}{2 \sin^2 \alpha + \sin \alpha - 1}.$$

Ayniyatni isbotlang (**368–369**):

**368.** 1)  $\cos^4 \alpha - \sin^4 \alpha + \sin 2\alpha = \sqrt{2} \cos\left(2\alpha - \frac{\pi}{4}\right);$

2)  $\cos \alpha + \cos\left(\frac{2\pi}{3} + \alpha\right) + \cos\left(\frac{2\pi}{3} - \alpha\right) = 0.$

**369.** 1)  $\frac{\sin 2\alpha + \sin 5\alpha - \sin 3\alpha}{\cos \alpha + 1 - 2 \sin^2 2\alpha} = 2 \sin \alpha;$

2)  $\frac{\sin \alpha + \sin 3\alpha + \sin 5\alpha + \sin 7\alpha}{\cos \alpha - \cos 3\alpha + \cos 5\alpha - \cos 7\alpha} = \operatorname{ctg} \alpha.$

**370.** Ko'paytma ko'rinishida yozing:

1)  $\cos 22^\circ + \cos 24^\circ + \cos 26^\circ + \cos 28^\circ;$       2)  $\cos \frac{\pi}{12} + \cos \frac{\pi}{4} + \cos \frac{5\pi}{6}.$

**371.**  $\operatorname{tg} \alpha + \operatorname{tg} \beta = \frac{\sin(\alpha + \beta)}{\cos \alpha \cos \beta}$  ayniyatni isbotlang va hisoblang:

1)  $\operatorname{tg} 267^\circ + \operatorname{tg} 93^\circ;$       2)  $\operatorname{tg} \frac{5\pi}{12} + \operatorname{tg} \frac{7\pi}{12}.$

**372.** Ko'paytuvchilarga ajrating:

1)  $1 - \cos \alpha + \sin \alpha;$       2)  $1 - 2\cos \alpha + \cos 2\alpha;$   
3)  $1 + \sin \alpha - \cos \alpha - \operatorname{tg} \alpha;$       4)  $1 + \sin \alpha + \cos \alpha + \operatorname{tg} \alpha.$

### V bobga doir mashqlar

**373.**  $0 < \alpha < \frac{\pi}{2}$  bo'lsin.  $P(1; 0)$  nuqtani:

1)  $\frac{\pi}{2} - \alpha;$  2)  $\alpha - \pi;$  3)  $\frac{3\pi}{2} - \alpha;$  4)  $\frac{\pi}{2} + \alpha;$  5)  $\alpha - \frac{\pi}{2};$  6)  $\pi - \alpha$

burchakka burish natijasida hosil bo'lgan nuqta qaysi chorakda yotishini aniqlang.

**374.** Burchak sinusi va kosinusining qiymatini toping:

1)  $3\pi;$       2)  $4\pi;$       3)  $3,5\pi;$   
4)  $\frac{5}{2}\pi;$       5)  $\pi k, k \in \mathbf{Z};$       6)  $(2k + 1)\pi, k \in \mathbf{Z}.$

**375.** Hisoblang:

1)  $\sin 3\pi - \cos \frac{3\pi}{2}$ ;                      2)  $\cos 0 - \cos 3\pi + \cos 3,5\pi$ ;

3)  $\sin \pi k + \cos 2\pi k$ , bunda  $k$  – butun son;

4)  $\cos \frac{(2k+1)\pi}{2} - \sin \frac{(4k+1)\pi}{2}$ , bunda  $k$  – butun son.

**376.** Toping:

1) agar  $\sin \alpha = \frac{\sqrt{3}}{3}$  va  $\frac{\pi}{2} < \alpha < \pi$  bo'lsa,  $\cos \alpha$  ni;

2) agar  $\cos \alpha = -\frac{\sqrt{5}}{3}$  va  $\pi < \alpha < \frac{3\pi}{2}$  bo'lsa,  $\operatorname{tg} \alpha$  ni;

3) agar  $\operatorname{tg} \alpha = 2\sqrt{2}$  va  $0 < \alpha < \frac{\pi}{2}$  bo'lsa,  $\sin \alpha$  ni;

4) agar  $\operatorname{ctg} \alpha = \sqrt{2}$  va  $\pi < \alpha < \frac{3\pi}{2}$  bo'lsa,  $\sin \alpha$  ni.

**377.** Ayniyatni isbotlang:

1)  $5\sin^2 \alpha + \operatorname{tg} \alpha \cos \alpha + 5\cos^2 \alpha = 5 + \sin \alpha$ ;

2)  $\operatorname{ctg} \alpha \sin \alpha - 2\cos^2 \alpha - 2\sin^2 \alpha = \cos \alpha - 2$ ;

3)  $\frac{3}{1+\operatorname{tg}^2 \alpha} = 3 \cos^2 \alpha$ ;                      4)  $\frac{5}{1+\operatorname{ctg}^2 \alpha} = 5 \sin^2 \alpha$ .

**378.** Ifodani soddalashtiring:

1)  $2 \sin(-\alpha) \cos\left(\frac{\pi}{2} - \alpha\right) - 2 \cos(-\alpha) \sin\left(\frac{\pi}{2} - \alpha\right)$ ;

2)  $3 \sin(\pi - \alpha) \cos\left(\frac{\pi}{2} - \alpha\right) + 3 \sin^2\left(\frac{\pi}{2} - \alpha\right)$ ;

3)  $(1 - \operatorname{tg}(-\alpha))(1 - \operatorname{tg}(\pi + \alpha) \cos^2 \alpha)$ ;

4)  $(1 + \operatorname{tg}^2(-\alpha))\left(\frac{1}{1+\operatorname{ctg}^2(-\alpha)}\right)$ .

**379.** Ifodani soddalashtiring va uning son qiymatini toping:

1)  $\sin\left(\frac{3}{2}\pi - \alpha\right) + \sin\left(\frac{3}{2}\pi + \alpha\right)$ , bunda  $\cos \alpha = \frac{1}{4}$ ;

2)  $\cos\left(\frac{\pi}{2} + \alpha\right) + \cos\left(\frac{3}{2}\pi - \alpha\right)$ , bunda  $\sin \alpha = \frac{1}{6}$ .

**380.** Hisoblang:

1)  $2\sin 75^\circ \cos 75^\circ$ ;

2)  $\cos^2 75^\circ - \sin^2 75^\circ$ ;

3)  $\sin 15^\circ$ ;

4)  $\sin 75^\circ$ .

**O'ZINGIZNI TEKSHIRIB KO'RING!**

1. Agar  $\sin \alpha = \frac{4}{5}$  va  $\frac{\pi}{2} < \alpha < \pi$  bo'lsa,  $\cos \alpha$ ,  $\operatorname{tg} \alpha$ ,  $\sin 2\alpha$  ni hisoblang.
2. Ifodaning qiymatini toping:
  - 1)  $4 \cos\left(-\frac{\pi}{3}\right) - \operatorname{tg} \frac{\pi}{4} + 2 \sin\left(-\frac{\pi}{6}\right) - \cos \pi$ ;
  - 2)  $\cos 150^\circ$ ;    3)  $\sin \frac{8\pi}{3}$ ;    4)  $\operatorname{tg} \frac{5\pi}{3}$ ;    5)  $\cos^2 \frac{\pi}{8} - \sin^2 \frac{\pi}{8}$ .
3. (*G'iyosiddin Jamshid al-Koshiy masalasi.*)  
 $\sin 3\alpha = 3\sin \alpha - 4\sin^3 \alpha$  ekanini isbotlang.
4. Ayniyatni isbotlang:
  - 1)  $3 - \cos^2 \alpha - \sin^2 \alpha = 2$ ;                      2)  $1 - \sin \alpha \cos \alpha \operatorname{ctg} \alpha = \sin^2 \alpha$ .
5. Ifodani soddalashtiring:
  - 1)  $\sin(\alpha - \beta) - \sin\left(\frac{\pi}{2} - \alpha\right) \sin(-\beta)$ ;    2)  $\sin^2 \alpha + \cos 2\alpha$ ;
  - 3)  $\operatorname{tg}(\pi - \alpha) \cos(\pi - \alpha) + \sin(4\pi + \alpha)$ .

**381.** Ifodani soddalashtiring:

- 1)  $\cos^2(\pi - \alpha) - \cos^2\left(\frac{\pi}{2} - \alpha\right)$ ;    2)  $2 \sin\left(\frac{\pi}{2} - \alpha\right) \cos\left(\frac{\pi}{2} - \alpha\right)$ ;
- 3)  $\frac{\cos^2(2\pi + \alpha) - \sin^2(\alpha + 2\pi)}{2 \cos(\alpha + 2\pi) \cos\left(\frac{\pi}{2} - \alpha\right)}$ ;    4)  $\frac{2 \sin(\pi - \alpha) \sin\left(\frac{\pi}{2} - \alpha\right)}{\sin^3\left(\alpha - \frac{\pi}{2}\right) - \sin^2(\alpha - \pi)}$ .

Hisoblang (**382–383**):

- 382.** 1)  $\sin \frac{47\pi}{6}$ ;    2)  $\operatorname{tg} \frac{25\pi}{4}$ ;    3)  $\operatorname{ctg} \frac{27\pi}{4}$ ;    4)  $\cos \frac{21\pi}{4}$ .
- 383.** 1)  $\cos \frac{23\pi}{4} - \sin \frac{15\pi}{4}$ ;    2)  $\sin \frac{25\pi}{3} - \operatorname{tg} \frac{10\pi}{3}$ ;
- 3)  $3\cos 3660^\circ + \sin(-1560^\circ)$ ;    4)  $\cos(-945^\circ) + \operatorname{tg} 1035^\circ$ .

**384.** Sonlarni taqqoslang.

- 1)  $\sin 3$  va  $\cos 4$ ;                      2)  $\cos 0$  va  $\sin 5$ .

**385.** Sonning ishorasini aniqlang:

- 1)  $\sin 3,5 \operatorname{tg} 3,5$ ;                      2)  $\cos 5,01 \sin 0,73$ ;  
3)  $\frac{\operatorname{tg} 13}{\cos 15}$ ;                      4)  $\sin 1 \cos 2 \operatorname{tg} 3$ .

**386.** Hisoblang:

- 1)  $\sin \frac{\pi}{8} \cos \frac{3\pi}{8} + \sin \frac{3\pi}{8} \cos \frac{\pi}{8}$ ;    2)  $\sin 165^\circ$ ;    3)  $\sin 105^\circ$ ;  
4)  $\sin \frac{\pi}{12}$ ;                      5)  $1 - 2 \sin^2 195^\circ$ ;    6)  $2 \cos^2 \frac{3\pi}{8} - 1$ .

**387.** Ifodani soddalashtiring:

- 1)  $(1 + \operatorname{tg}(-\alpha))(1 - \operatorname{ctg}(-\alpha)) - \frac{\sin(-\alpha)}{\cos(-\alpha)}$ ;    2)  $\frac{\operatorname{ctg} \alpha + \operatorname{tg}(-\alpha)}{\cos \alpha + \sin(-\alpha)} + \frac{\operatorname{tg}(-\alpha)}{\sin \alpha}$ .

**388.** Berilgan:  $\sin \alpha = \frac{\sqrt{5}}{3}$  va  $\frac{\pi}{2} < \alpha < \pi$ .  $\cos \alpha$ ,  $\operatorname{tg} \alpha$ ,  $\operatorname{ctg} \alpha$ ,  $\sin 2\alpha$ ,  $\cos 2\alpha$  larning qiymatlarini hisoblang.

Ifodani soddalashtiring (**389–391**):

**389.** 1)  $\cos^3 \alpha \sin \alpha - \sin^3 \alpha \cos \alpha$ ;                      2)  $\frac{\sin \alpha + \sin 2\alpha}{1 + \cos \alpha + \cos 2\alpha}$ .

**390.** 1)  $\frac{\sin 2\alpha - \sin 2\alpha \cos 2\alpha}{4 \cos \alpha}$ ;                      2)  $\frac{2 \cos^2 2\alpha}{\sin 4\alpha \cos 4\alpha + \sin 4\alpha}$ ;

3)  $\frac{\cos 2\alpha + \sin 2\alpha \cos 2\alpha}{2 \sin^2 \alpha - 1}$ ;                      4)  $\frac{(\cos \alpha - \sin \alpha)^2}{\sin 2\alpha \cos 2\alpha - \cos 2\alpha}$ .

**391.** 1)  $\frac{\cos^2 x}{1 - \sin x} - \sin(\pi - x)$ ;                      2)  $\frac{\cos^2 x}{1 + \sin x} + \cos(1,5\pi + x)$ ;

3)  $\frac{\sin^2 x}{1 + \cos x} - \sin(1,5\pi + x)$ ;                      4)  $\frac{\sin^2 x}{1 - \cos x} + \cos(3\pi - x)$ .

**392.** 1) Agar  $\operatorname{tg} \alpha = -\frac{3}{4}$  va  $\operatorname{tg} \beta = 2,4$  bo'lsa,  $\operatorname{tg}(\alpha + \beta)$  ni;

2) agar  $\operatorname{ctg} \alpha = \frac{4}{3}$  va  $\operatorname{ctg} \beta = -1$  bo'lsa,  $\operatorname{ctg}(\alpha + \beta)$  ni hisoblang.

**393.** Ifodani soddalashtiring:

1)  $2 \sin\left(\frac{\pi}{4} + 2\alpha\right) \sin\left(\frac{\pi}{4} - 2\alpha\right)$ ;    2)  $2 \cos\left(\frac{\pi}{4} + 2\alpha\right) \cos\left(\frac{\pi}{4} - 2\alpha\right)$ .



1.  $153^\circ$  ning radian o'lchovini toping.

- A)  $\frac{17\pi}{20}$ ; B)  $\frac{19\pi}{20}$ ; C)  $17\pi$ ; D)  $\frac{2\pi}{9}$ ; E)  $\frac{153}{\pi}$ .

2.  $0,65\pi$  ning gradus o'lchovini toping.

- A)  $11,7^\circ$ ; B)  $117^\circ$ ; C)  $116^\circ$ ; D)  $118^\circ$ ; E)  $117,5^\circ$ .

3. Ko'paytmalarning qaysi biri manfiy?

- A)  $\cos 314^\circ \sin 147^\circ$ ; B)  $\operatorname{tg} 200^\circ \operatorname{ctg} 201^\circ$ ; C)  $\cos 163^\circ \cos 295^\circ$ ;  
D)  $\sin 170^\circ \operatorname{ctg} 250^\circ$ ; E)  $\cos 215^\circ \operatorname{tg} 315^\circ$ .

4. Ko'paytmaning qaysi biri musbat?

- A)  $\sin 2 \cos 2 \sin 1 \sin 1^\circ$ ; B)  $\operatorname{tg} 8^\circ \operatorname{ctg} 8 \operatorname{ctg} 10^\circ \operatorname{ctg} \sqrt{10}$ ;  
C)  $\sin 9^\circ \sin 9 \cos 9^\circ \cos 9$ ; D)  $\cos 10^\circ \cos 10 \cos 11^\circ \cos \sqrt{11}$ ;  
E)  $\operatorname{tg} 7,5^\circ \operatorname{tg} 7,5 \operatorname{ctg} 3^\circ \operatorname{ctg} 3$ .

5.  $\left(\frac{\sqrt{3}}{2}; \frac{1}{2}\right)$  nuqtaga tushish uchun  $(1; 0)$  nuqtani burish kerak bo'lgan barcha burchaklarni toping?

- A)  $30^\circ + \pi k, k \in \mathbf{Z}$ ; B)  $-\frac{\pi}{6} + \pi k, k \in \mathbf{Z}$ ; C)  $\frac{\pi}{6} + \pi k, k \in \mathbf{Z}$ ;  
D)  $2\pi + \pi k, k \in \mathbf{Z}$ ; E)  $\frac{\pi}{6} + 2\pi k, k \in \mathbf{Z}$ .

6.  $(1; 0)$  nuqtani  $\frac{5\pi}{2} + 2\pi k, k \in \mathbf{Z}$  burchakka burishdan hosil bo'ladigan nuqtaning koordinatalarini toping.

- A)  $(0; 1)$ ; B)  $(0; -1)$ ; C)  $(1; 0)$ ; D)  $(-1; 0)$ ; E)  $(0; \frac{\pi}{2})$ .

7. Sonlarni o'sish tartibida yozing:

$$a = \sin 1,57; b = \cos 1,58; c = \sin 3.$$

- A)  $a < c < b$ ; B)  $b < c < a$ ; C)  $c < a < b$ ;  
D)  $b < a < c$ ; E)  $a < b < c$ .

8. Sonlarni kamayish tartibida yozing:

$$a = \cos 2; b = \cos 2^\circ; c = \sin 2; d = \sin 2^\circ.$$

- A)  $a > c > d > b$ ; B)  $d > c > b > a$ ; C)  $b > c > d > a$ ;  
D)  $c > d > b > a$ ; E)  $d > a > b > c$ .



9. Hisoblang:  $\frac{\sin 136^\circ \cdot \cos 46^\circ - \sin 46^\circ \cdot \cos 224^\circ}{\sin 110^\circ \cdot \cos 40^\circ - \sin 20^\circ \cdot \cos 50^\circ}$ .
- A)  $\cos 40^\circ$ ; B) 0,5; C)  $\sin 44^\circ$ ; D) 2; E) -2.
10. Hisoblang:  $\frac{\sin 10^\circ \cdot \cos 130^\circ - \sin 10^\circ \cdot \cos 220^\circ}{\sin 153^\circ \cdot \cos 147^\circ - \sin 27^\circ \cdot \cos 33^\circ}$ .
- A)  $\sin 80^\circ$ ; B) -1; C)  $\frac{\sqrt{3}}{2}$ ; D)  $-\frac{\sqrt{3}}{2}$ ; E) 1.
11. Hisoblang:  $\cos(-225^\circ) + \sin 675^\circ + \operatorname{tg}(-1035^\circ)$ .
- A) 1; B) -1; C)  $\sqrt{2}$ ; D)  $-\frac{\sqrt{2}}{2}$ ; E)  $\frac{\sqrt{2}}{2}$ .
12.  $\sin \alpha = 0,6$  bo'lsa,  $\operatorname{tg} 2\alpha$  ni toping ( $0 < \alpha < \frac{\pi}{2}$ ).
- A) 3,42; B)  $3\frac{3}{7}$ ; C)  $\frac{7}{24}$ ; D)  $-\frac{7}{24}$ ; E) 0,96.
13.  $\operatorname{tg} \alpha = \sqrt{5}$  bo'lsa,  $\sin 2\alpha$  ni toping.
- A)  $\frac{3\sqrt{5}}{5}$ ; B)  $-\frac{\sqrt{5}}{3}$ ; C)  $\frac{\sqrt{5}}{3}$ ; D)  $\sqrt{5}$ ; E)  $\frac{\sqrt{5}}{6}$ .
14.  $\operatorname{tg} \alpha = \sqrt{7}$  bo'lsa,  $\cos 2\alpha$  ni toping.
- A)  $\frac{4}{3}$ ; B)  $-\frac{4}{3}$ ; C)  $\frac{3}{4}$ ; D)  $-\frac{3}{4}$ ; E)  $-1\frac{1}{4}$ .
15. Soddalashtiring:  $\frac{\cos\left(\frac{\pi}{2} - \alpha\right)}{\sin(\pi + \alpha)}$ .
- A)  $\frac{\pi}{2} + \frac{\alpha}{2}$ ; B) 1; C) 0,5; D)  $-\frac{1}{2}$ ; E) -1.
16. Soddalashtiring:  $\frac{\sin 2\alpha + \sin(\pi - \alpha) \cdot \cos \alpha}{\sin(\pi - \alpha)}$ .
- A)  $3\sin \alpha$ ; B)  $\frac{1}{3}\sin \alpha$ ; C)  $-\sin \alpha$ ; D)  $\frac{1}{3}\cos \alpha$ ; E)  $3\sin 2\alpha$ .

17.  $\operatorname{tg}\alpha = \sqrt{7}$  bo'lsa,  $\frac{4\sin^4\alpha}{5\sin^2\alpha + 15\cos^2\alpha}$  ni hisoblang.  
 A) 0,59; B) 0,49; C) -0,49; D) 0,2; E)  $\frac{\sqrt{7}}{20}$ .
18.  $\cos\alpha + \sin\alpha = \frac{1}{3}$  bo'lsa,  $\sin^4\alpha + \cos^4\alpha$  ni toping.  
 A)  $\frac{81}{49}$ ; B)  $-\left(\frac{7}{9}\right)^2$ ; C)  $\frac{49}{81}$ ; D)  $-1\frac{32}{49}$ ; E)  $\frac{2}{81}$ .
19. Hisoblang:  $\sin 100^\circ \cdot \cos 440^\circ + \sin 800^\circ \cdot \cos 460^\circ$ .  
 A)  $\frac{\sqrt{3}}{2}$ ; B) 1; C) -1; D) 0; E)  $\frac{\sqrt{2}}{2}$ .
20. Soddashtiring:  $\frac{\sin 3\alpha}{\sin \alpha} + \frac{\cos 3\alpha}{\cos \alpha}$ .  
 A)  $\sin\alpha\cos\alpha$ ; B)  $-2\sin 4\alpha$ ; C)  $\sin 4\alpha$ ; D)  $2\cos 2\alpha$ ; E)  $4\cos 2\alpha$ .
21.  $8x^2 - 6x + 1 = 0$  tenglamaning ildizlari  $\sin\alpha$  va  $\sin\beta$  bo'lib,  $\alpha, \beta$  - I chorakda bo'lsa,  $\sin(\alpha + \beta)$  ni toping.  
 A)  $\frac{\sqrt{3}(4 + \sqrt{5})}{16}$ ; B)  $\frac{\sqrt{2}(4 + \sqrt{5})}{16}$ ; C)  $\frac{\sqrt{3}(4 - \sqrt{5})}{16}$ ;  
 D)  $-\frac{\sqrt{3}(4 + \sqrt{5})}{16}$ ; E)  $\frac{\sqrt{3}(4 + \sqrt{5})}{18}$ .
22.  $6x^2 - 5x + 1 = 0$  tenglamaning ildizlari  $\cos\alpha$  va  $\cos\beta$  bo'lib,  $\alpha, \beta$  lar I chorakda bo'lsa,  $\cos(\alpha + \beta)$  ni toping.  
 A)  $\frac{1-2\sqrt{6}}{6}$ ; B)  $\frac{2\sqrt{6}-1}{6}$ ; C)  $\frac{2\sqrt{6}-1}{7}$ ;  
 D)  $\frac{1-2\sqrt{6}}{5}$ ; E)  $\frac{1}{6}$ .
23.  $x$  ni toping:  $2(x + \sqrt{2}) = \cos\left(\frac{\pi}{2} - 2\alpha\right) + 2\sin\left(\frac{3\pi}{2} + \alpha\right) \cdot \sin(\pi - \alpha)$ .  
 A)  $\frac{\sqrt{2}}{2}$ ; B)  $\sqrt{2}$ ; C)  $-\sqrt{2}$ ; D)  $2\sqrt{2}$ ; E)  $-2\sqrt{2}$ .
24.  $x^2 - 7x + 12 = 0$  tenglamaning ildizlari  $\operatorname{tg}\alpha$  va  $\operatorname{tg}\beta$  bo'lsa,  $\operatorname{tg}(\alpha + \beta)$  ni toping:  
 A) 1; B)  $\frac{7}{11}$ ; C)  $\sqrt{3}$ ; D)  $-\frac{7}{11}$ ; E)  $-\frac{\sqrt{3}}{2}$ .



*Abu Rayhon Beruniy masalalari*

1. Quduq silindr shaklida bo'lib, uning tubi quduq labidagi  $A$  nuqtadan  $\alpha$  burchak ostida, quduq devori davomidagi  $B$  nuqtadan  $\beta$  burchak ostida ko'rindi (72- rasm). Agar  $AB = a$  bo'lsa, quduqning chuqurligini toping:

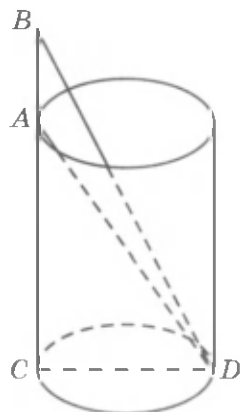

72- rasm.

Berilgan:

$$\angle CAD = \alpha, \angle ABD = \beta, AB = a.$$

Topish kerak:  $AC = ?$

2. Minora yerdagi  $A$  nuqtadan  $\alpha$  burchak ostida,  $B$  nuqtadan esa  $\beta$  burchak ostida ko'rinadi (73- rasm).  $AB = a$  bo'lsa, minoraning balandligini toping.

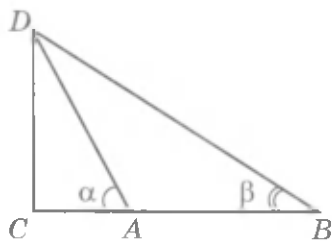

73- rasm.

Berilgan:

$$\angle CAD = \alpha, \angle ABD = \beta, AB = a.$$

Topish kerak:  $CD = ?$

*Giyosiddin Jamshid al-Koshiy masalasi.*

3. Ixtiyoriy  $\alpha$  burchak uchun

$$\sin\left(45^\circ + \frac{\alpha}{2}\right) = \sqrt{\frac{1 + \sin \alpha}{2}}$$

bo'lishini isbotlang.

*Mashhur matematik Abulvafo Muhammad al-Buzjoniy (940-998) masalasi:*

4. Ixtiyoriy  $\alpha$  va  $\beta$  uchun

$$\sin(\alpha - \beta) = \sqrt{\sin^2 \alpha - \sin^2 \alpha \cdot \sin^2 \beta} - \sqrt{\sin^2 \beta - \sin^2 \alpha \cdot \sin^2 \beta}$$

bo'lishini isbotlang.



Mirzo Ulug'bek  
(1394–1449)

Matematikaning, xususan trigonometriyaning rivojiga buyuk allomalar Muhammad al-Xorazmiy, Ahmad Farg'oniy, Abu Rayhon Beruniy, Mirzo Ulug'bek, Ali Qushchi, G'iyosiddin Jamshid al-Koshiy katta hissa qo'shganlar. Yulduzlarning osmon sferasidagi koordinatalarini aniqlash, sayyoralarning harakatlarini kuzatish, Oy va Quyosh tutilishini oldindan aytib berish va boshqa ilmiy, amaliy ahamiyatga molik masalalar aniq hisoblarni, bu hisoblarga asoslangan jadvallar tuzishni taqozo etar edi. Ana shunday astronomik (trigonometrik) jadvallar Sharqda «Zij»lar deb atalgan.

Muhammad al-Xorazmiy, Abu Rayhon Beruniy, Mirzo Ulug'bek kabi olimlarimizning matematik asarlari bilan birga «Zij»lari ham mashhur bo'lgan, ular lotin va boshqa tillarga tarjima qilingan, Yevropada matematikaning, astronomiyaning taraqqiyotiga salmoqli ta'sir o'tkazgan.

Beruniyning «Qonuni Ma'sudiy» asarida sinuslar jadvali 15 minut oraliq bilan, tangenslar jadvali  $1^\circ$  oraliq bilan  $10^{-8}$  gacha aniqlikda berilgan. Nihoyatda aniq «Zij»lardan biri Mirzo Ulug'bekning «Zij»i – «Ziji Ko'ragoniy»dir. Bunda sinuslar jadvali 1 minut oraliq bilan, tangenslar jadvali  $0^\circ$  dan  $45^\circ$  gacha 1 minut oraliq bilan,  $46^\circ$  dan  $90^\circ$  gacha esa 5 minut oraliq bilan  $10^{-10}$  gacha aniqlikda berilgan.

G'iyosiddin Jamshid al-Koshiy «Vatar va sinus haqida risola»sida  $\sin 1^\circ$  ni verguldan so'ng 17 xona aniqligida hisoblaydi:

$$\sin 1^\circ = 0,017452406437283512\dots$$

Aylana uzunligi unga ichki va tashqi chizilgan muntazam  $3 \cdot 2^n$  – ko'pburchaklar perimetrlarining o'rta arifmetigiga teng deb,  $n = 28$  bo'lganda Jamshid al-Koshiy «Aylana haqida risola» asarida  $2\pi$  uchun quyidagi natijani oldi:

$$2\pi = 6,2831853071795865\dots$$

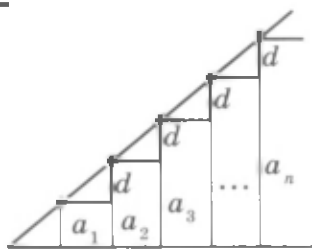

## 30- §.

## ARIFMETIK PROGRESSIYA

Quyidagi masalani ko'raylik.

**Masala.** O'quvchi sinovdan o'tish uchun tayyorgarlik ko'rib har kuni 5 ta dan sinov masalalarini yechishni rejalashtirdi. Har bir kun yechilishi rejalashtirilgan sinov masalalarining soni qanday o'zgarib boradi?

Rejalashtirilgan masalalar soni har bir kunga kelib quyidagicha o'zgarib boradi:

1- kun	2- kun	3- kun	4- kun ...
5 ta	10 ta	15 ta	20 ta ...

Natijada quyidagi ketma-ketlikni hosil qilamiz:

$$5, 10, 15, 20, 25, \dots$$

$a_n$  – orqali  $n$ - kunga kelib yechilishi lozim bo'lgan barcha masalalar sonini belgilaylik. Masalan:

$$a_1 = 5, a_2 = 10, a_3 = 15, \dots$$

Hosil qilingan

$$a_1, a_2, a_3, \dots, a_n, \dots$$

sonlar *sonli ketma-ketlik* deyiladi.

Bu ketma-ketlikda ikkinchisidan boshlab uning har bir hadi oldingi hadga ayni bir xil 5 sonini qo'shilganiga teng. Bunday ketma-ketlik *arifmetik progressiya* deyiladi.

**Ta'rif.** Agar  $a_1, a_2, \dots, a_n, \dots$  sonli ketma-ketlikda barcha natural  $n$  lar uchun



$$a_{n+1} = a_n + d$$

(bunda  $d$  – biror son) tenglik bajarilsa, bunday ketma-ketlik arifmetik progressiya deyiladi.

Bu formuladan  $a_{n+1} - a_n = d$  ekanligi kelib chiqadi.  $d$  son arifmetik progressiyaning ayirmasi deyiladi.

### Misollar.

1) Sonlarning  $1, 2, 3, 4, \dots, n, \dots$  natural qatori arifmetik progressiyani tashkil qiladi. Bu progressiyaning ayirmasi  $d = 1$ .

2) Butun manfiy sonlarning  $-1, -2, -3, \dots, -n, \dots$  ketma-ketligi ayirmasi  $d = -1$  bo'lgan arifmetik progressiyadir.

3)  $3, 3, 3, \dots, 3, \dots$  ketma-ketlik ayirmasi  $d = 0$  bo'lgan arifmetik progressiyadan iborat.

**1-masala.**  $a_n = 1,5 + 3n$  formula bilan berilgan ketma-ketlik arifmetik progressiya bo'lishini isbotlang.

$\Delta a_{n+1} - a_n$  ayirma barcha  $n$  uchun ayni bir xil ( $n$  ga bog'liq emas) ekanligini ko'rsatish talab qilinadi.

Berilgan ketma-ketlikning  $(n + 1)$ -hadini yozamiz:

$$a_{n+1} = 1,5 + 3(n + 1).$$

Shuning uchun

$$a_{n+1} - a_n = 1,5 + 3(n + 1) - (1,5 + 3n) = 3.$$

Demak,  $a_{n+1} - a_n$  ayirma  $n$  ga bog'liq emas.  $\blacktriangle$

Arifmetik progressiyaning ta'rifiga ko'ra  $a_{n+1} = a_n + d$ ,  $a_{n-1} = a_n - d$ , bundan

$$a_n = \frac{a_{n-1} + a_{n+1}}{2}, n > 1.$$



Shunday qilib, arifmetik progressiyaning ikkinchi hadidan boshlab har bir hadi unga qo'shni bo'lgan ikkita hadning o'rta arifmetigiga teng. «Arifmetik» progressiya degan nom shu bilan izohlanadi.

Agar  $a_1$  va  $d$  berilgan bo'lsa, u holda arifmetik progressiyaning qolgan hadlarini  $a_{n+1} = a_n + d$  formula bo'yicha hisoblash mumkinligini

ta'kidlaymiz. Bunday usul bilan progressiyaning bir necha dastlabki hadini hisoblash qiyinchilik tug'dirmaydi; biroq, masalan,  $a_{100}$  uchun talaygina hisoblashlar talab qilinadi. Odatda buning uchun  $n$ -had formulasidan foydalaniladi.

Arifmetik progressiyaning ta'rifiga ko'ra

$$a_2 = a_1 + d,$$

$$a_3 = a_2 + d = a_1 + 2d,$$

$$a_4 = a_3 + d = a_1 + 3d \text{ va h.k.}$$

Umuman,



$$a_n = a_1 + (n - 1)d, \quad (1)$$

chunki arifmetik progressiyaning  $n$ - hadi uning birinchi hadiga  $d$  sonini  $(n - 1)$  marta qo'shish natijasida hosil qilinadi.

(1) formula *arifmetik progressiyaning  $n$ -hadi formulasi* deyiladi.

**2 - masala.** Agar  $a_1 = -6$  va  $d = 4$  bo'lsa, arifmetik progressiyaning yuzinchi hadini toping.

$$\triangle (1) \text{ formula bo'yicha: } a_{100} = -6 + (100 - 1) \cdot 4 = 390. \blacktriangle$$

**3 - masala.** 99 soni 3, 5, 7, 9, ... arifmetik progressiyaning hadi. Shu hadning nomerini toping.

$\triangle$  Aytaylik,  $n$  - izlangan nomer bo'lsin.  $a_1 = 3$  va  $d = 2$  bo'lgani uchun  $a_n = a_1 + (n - 1)d$  formulaga ko'ra:  $99 = 3 + (n - 1) \cdot 2$ . Shuning uchun  $99 = 3 + 2n - 2$ ;  $98 = 2n$ ,  $n = 49$ .

**J a v o b:**  $n = 49$ .  $\blacktriangle$

**4 - masala.** Arifmetik progressiyada  $a_8 = 130$  va  $a_{12} = 166$ .  $n$ -hadining formulasini toping.

$\triangle$  (1) formuladan foydalaniib, topamiz:

$$a_8 = a_1 + 7d, \quad a_{12} = a_1 + 11d.$$

$a_8$  va  $a_{12}$  larning berilgan qiymatlarini qo'yib,  $a_1$  va  $d$  ga nisbatan tenglamalar sistemasini hosil qilamiz:

$$\begin{cases} a_1 + 7d = 130, \\ a_1 + 11d = 166. \end{cases}$$

Ikkinchi tenglamadan birinchi tenglamani ayirib, hosil qilamiz:

$$4d = 36, \quad d = 9.$$

Demak,  $a_1 = 130 - 7d = 130 - 63 = 67$ .

Progressiya  $n$ -hadi formulasini yozamiz:

$$a_n = 67 + 9(n - 1) = 67 + 9n - 9 = 58 + 9n.$$

**Javob:**  $a_n = 9n + 58$ . ▲

**5-masala.** Burchakning bir tomonida uning uchidan boshlab teng kesmalar ajratiladi. Ularning oxirlaridan parallel to'g'ri chiziqlar o'tkaziladi (74-rasm). Shu to'g'ri chiziqlarning burchak tomonlari orasidagi  $a_1, a_2, a_3, \dots$  kesmalarining uzunliklari arifmetik progressiya tashkil qilishini isbotlang.

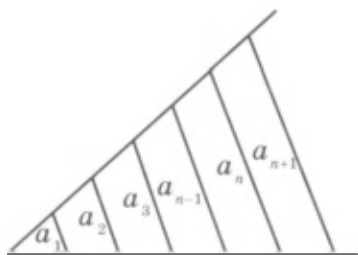

74-rasm.

△ Asoslari  $a_{n-1}$  va  $a_{n+1}$  bo'lgan trapeziyada uning o'rta chizig'i  $a_n$  ga teng. Shuning uchun

$$a_n = \frac{a_{n-1} + a_{n+1}}{2}.$$

Bundan  $2a_n = a_{n-1} + a_{n+1}$  yoki  $a_{n+1} - a_n = a_n - a_{n-1}$ .

Ketma-ketlikning har bir hadi bilan undan oldingi hadi ayirmasi ayni bir xil son bo'lgani uchun bu ketma-ketlik arifmetik progressiya bo'ladi. ▲

## Mashqlar

**394.** (Og'zaki.) Arifmetik progressiyaning birinchi hadini va ayirmasini ayting:

1)  $6, 8, 10, \dots$ ;

2)  $7, 9, 11, \dots$ ;

3)  $25, 21, 17, \dots$ ;

4)  $-12, -9, -6, \dots$ .

**395.** Agar:

1)  $a_1 = 2$  va  $d = 5$ ;

2)  $a_1 = -3$  va  $d = 2$

bo'lsa, arifmetik progressiyaning dastlabki beshta hadini yozing.

**396.**  $n$ -hadining formulasi bilan berilgan quyidagi ketma-ketlik arifmetik progressiya bo'lishini isbotlang:

1)  $a_n = 3 - 4n$ ;

2)  $a_n = -5 + 2n$ ;

3)  $a_n = 3(n + 1)$ ;

4)  $a_n = 2(3 - n)$ .

**397.** Arifmetik progressiyada:

1) agar  $a_1 = 2$ ,  $d = 3$  bo'lsa,  $a_{15}$  ni toping;



2) agar  $a_1 = 3$ ,  $d = 4$  bo'lsa,  $a_{20}$  ni toping;

3) agar  $a_1 = -3$ ,  $d = -2$  bo'lsa,  $a_{18}$  ni toping;

4) agar  $a_1 = -2$ ,  $d = -4$  bo'lsa,  $a_{11}$  ni toping.

398. Arifmetik progressiyaning  $n$ -hadi formulasini yozing:

1) 1, 6, 11, 16, ...;                      2) 25, 21, 17, 13, ...;

3) -4, -6, -8, -10, ...;                      4) 1, -4, -9, -14, ... .

399. -22 soni 44, 38, 32, ... arifmetik progressiyaning hadi. Shu sonning nomerini toping.

400. 12 soni -18, -15, -12, ... arifmetik progressiyaning hadi bo'ladimi?

401. -59 soni 1, -5 ... arifmetik progressiyaning hadi. Uning nomerini toping. -46 soni shu progressiyaning hadi bo'ladimi?

402. Agar arifmetik progressiyada:

1)  $a_1 = 7$ ,  $a_{16} = 67$ ;                      2)  $a_1 = -4$ ,  $a_9 = 0$

bo'lsa, uning ayirmasini toping.

403. Arifmetik progressiyaning ayirmasi 1,5 ga teng. Agar:

1)  $a_9 = 12$ ;                                      2)  $a_7 = -4$  bo'lsa,  $a_1$  ni toping.

404. Agar arifmetik progressiyada:

1)  $d = -3$ ,  $a_{11} = 20$ ;                      2)  $a_{21} = -10$ ,  $a_{22} = -5,5$

bo'lsa, uning birinchi hadini toping.

405. Agar arifmetik progressiyada:

1)  $a_3 = 13$ ,  $a_6 = 22$ ;                      2)  $a_2 = -7$ ,  $a_7 = 18$

bo'lsa, uning  $n$ -hadi formulasini toping.

---

406.  $n$  ning qanday qiymatlarida 15, 13, 11, ... arifmetik progressiyaning hadlari manfiy bo'ladi?

407. Arifmetik progressiyada  $a_1 = -10$ ,  $d = 0,5$  bo'lsa,  $n$  ning qanday qiymatlarida  $a_n < 2$  tengsizlik bajariladi?

408. Agar arifmetik progressiyada:

1)  $a_8 = 126$ ,  $a_{10} = 146$ ;                      2)  $a_8 = -64$ ,  $a_{10} = -50$ ;

3)  $a_8 = -7$ ,  $a_{10} = 3$ ;                      4)  $a_8 = 0,5$ ,  $a_{10} = -2,5$

bo'lsa, uning to'qqizinchi hadini va ayirmasini toping.

409. Erkin tushuvchi jism birinchi sekundda 4,9 m yo'l bosadi, keyingi har bir sekundda esa oldingisidan 9,8 m ortiq yo'l bosadi. Tushayotgan jism beshinchi sekundda qancha masofani bosib o'tadi?

410. Havo vannasini olish yo'li bilan davolanishda birinchi kuni davolanish 15 min davom etadi, keyingi har bir kunda uni 10 min dan oshirib boriladi. Vanna olish ko'pi bilan 1 soat 45 min davom etishi uchun ko'rsatilgan tartibda havo vannasini olish necha kun davom etadi?

411. Arifmetik progressiya uchun  $a_n + a_k = a_{n-1} + a_{k+1}$  tenglik o'rinli ekanligini isbotlang. Agar  $a_7 + a_8 = 30$  bo'lsa,  $a_{10} + a_5$  ni toping.

412. Arifmetik progressiya uchun

$$a_n = \frac{a_{n+k} + a_{n-k}}{2}$$

tenglik o'rinli ekanligini isbotlang. Agar  $a_{10} + a_{30} = 120$  bo'lsa,  $a_{20}$  ni toping.

### 31- §.

### ARIFMETIK PROGRESSIYA DASTLABKI n TA HADINING YIG'INDISI

**1 - m a s a l a .** 1 dan 100 gacha bo'lgan barcha natural sonlar yig'indisini toping.

△ Bu yig'indini ikki usul bilan yozamiz:

$$S = 1 + 2 + 3 + \dots + 99 + 100,$$

$$S = 100 + 99 + 98 + \dots + 2 + 1.$$

Bu tengliklarni hadlab qo'shamiz:

$$2S = \frac{101 + 101 + 101 + \dots + 101 + 101}{100 \text{ ta qo'shiluvchi}}$$

Shuning uchun  $2S = 101 \cdot 100$ , bundan  $S = 101 \cdot 50 = 5050$ . ▲

Endi ixtiyoriy

$$a_1, a_2, \dots, a_n, \dots$$

arifmetik progressiyani qaraymiz.  $S_n$  - shu progressiya dastlabki  $n$  ta hadining yig'indisi bo'lsin:

$$S_n = a_1 + a_2 + \dots + a_{n-1} + a_n.$$

***T e o r e m a .*** Arifmetik progressiya dastlabki  $n$  ta hadining yig'indisi quyidagiga teng:



$$S_n = \frac{a_1 + a_n}{2} n. \quad (1)$$

○  $S_n$  ni ikki usul bilan yozib olamiz:

$$S_n = a_1 + a_2 + \dots + a_{n-1} + a_n,$$

$$S_n = a_n + a_{n-1} + \dots + a_2 + a_1.$$

Arifmetik progressiyaning ta'rifiga ko'ra bu tengliklarni quyidagicha yozish mumkin:

$$S_n = a_1 + (a_1 + d) + (a_1 + 2d) + \dots + (a_1 + (n-1)d), \quad (2)$$

$$S_n = a_n + (a_n - d) + (a_n - 2d) + \dots + (a_n - (n-1)d). \quad (3)$$

(2) va (3) tengliklarni hadlab qo'shamiz:

$$2S_n = \underbrace{(a_1 + a_n) + (a_1 + a_n) + \dots + (a_1 + a_n)}_{n \text{ ta qo'shiluvchi}}$$

Demak,  $2S_n = (a_1 + a_n)n$ , bundan  $S_n = \frac{a_1 + a_n}{2} n$ . ●

**2-masala.** Dastlabki  $n$  ta natural son yig'indisini toping.

△ Natural sonlarning

$$1, 2, 3, 4, 5, 6, \dots, n, \dots$$

ketma-ketligi ayirmasi  $d = 1$  bo'lgan arifmetik progressiyadir.  $a_1 = 1$  va  $a_n = n$  bo'lgani uchun (1) formula bo'yicha topamiz:

$$S_n = 1 + 2 + 3 + \dots + n = \frac{1+n}{2} \cdot n.$$

Shunday qilib,

$$1 + 2 + 3 + \dots + n = \frac{n(n+1)}{2}. \blacktriangle$$

**3-masala.** Agar  $38 + 35 + 32 + \dots + (-7)$  yig'indining qo'shiluvchilari arifmetik progressiyaning ketma-ket hadlari bo'lsa, shu yig'indini toping.

△ Shartga ko'ra  $a_1 = 38$ ,  $d = -3$ ,  $a_n = -7$ . Endi  $a_n = a_1 + (n-1)d$  formulani qo'llab,  $-7 = 38 + (n-1)(-3)$  ni hosil qilamiz, bundan  $n = 16$ .

$S_n = \frac{a_1 + a_n}{2} n$  formula bo'yicha topamiz:

$$S_{16} = \frac{38-7}{2} \cdot 16 = 248. \blacktriangle$$

**4\*-masala.** Yig'indi 153 ga teng bo'lishi uchun 1 dan boshlab nechta ketma-ket natural sonlarni qo'shish kerak?

△ Sonlarning natural qatori – ayirmasi  $d = 1$  bo‘lgan arifmetik progressiya. Shartga ko‘ra  $a_1 = 1$ ,  $S_n = 153$ . Dastlabki  $n$  ta had yig‘indisi formulasini quyidagicha o‘zgartiramiz:

$$S_n = \frac{a_1 + a_n}{2} \cdot n = \frac{a_1 + a_1 + (n-1)d}{2} \cdot n = \frac{2a_1 + (n-1)d}{2} \cdot n.$$

Berilganlardan foydalanib, noma'lum  $n$  ga nisbatan tenglama hosil qilamiz:

$$153 = \frac{2 \cdot 1 + (n-1) \cdot 1}{2} \cdot n,$$

bundan

$$306 = 2n + (n-1)n, \quad n^2 + n - 306 = 0.$$

Bu tenglamani yechib, topamiz:

$$n_{1,2} = \frac{-1 \pm \sqrt{1+1224}}{2} = \frac{-1 \pm 35}{2},$$

$$n_1 = -18, \quad n_2 = 17.$$

Qo‘shiluvchilar soni manfiy bo‘lishi mumkin emas, shuning uchun  $n = 17$ . ▲

### *Mashqlar*

**413.** Agar arifmetik progressiyada:

1)  $a_1 = 1$ ,  $a_n = 20$ ,  $n = 50$ ;                      3)  $a_1 = -1$ ,  $a_n = -40$ ,  $n = 20$ ;

2)  $a_1 = 1$ ,  $a_n = 200$ ,  $n = 100$ ;                      4)  $a_1 = 2$ ,  $a_n = 100$ ,  $n = 50$

bo‘lsa, uning dastlabki  $n$  ta hadining yig‘indisini toping.

**414.** 2 dan 98 gacha bo‘lgan barcha natural sonlar yig‘indisini toping (98 ham yig‘indiga kiradi).

**415.** 1 dan 133 gacha bo‘lgan barcha toq sonlarning yig‘indisini toping (133 ham yig‘indiga kiradi).

**416.** Agar arifmetik progressiyada:

1)  $a_1 = -5$ ,  $d = 0,5$ ;

2)  $a_1 = \frac{1}{2}$ ,  $d = -3$

bo‘lsa, uning dastlabki o‘n ikkita hadi yig‘indisini toping.

**417.** 1) agar  $n = 11$  bo‘lsa, 9; 13; 17; ...;

2) agar  $n = 12$  bo‘lsa, -16; -10; -4; ...

arifmetik progressiyaning dastlabki  $n$  ta hadi yig‘indisini toping.

418. Agar:

1)  $3 + 6 + 9 + \dots + 273$ ;      2)  $90 + 80 + 70 + \dots + (-60)$

yig'indining qo'shiluvchilari arifmetik progressiyaning ketma-ket hadlari bo'lsa, shu yig'indini toping.

419. Barcha ikki xonali, barcha uch xonali sonlar yig'indisini toping.

---

420. Arifmetik progressiya  $n$ - hadining formulasi bilan berilgan. Agar:

1)  $a_n = 3n + 5$ ;      2)  $a_n = 7 + 2n$  bo'lsa,  $S_{50}$  ni toping.

421. Yig'indi 75 ga teng bo'lishi uchun 3 dan boshlab nechta ketma-ket natural sonni qo'shish kerak?

422. Agar arifmetik progressiyada:

1)  $a_1 = 10$ ,  $n = 14$ ,  $S_{14} = 1050$ ;

2)  $a_1 = 2\frac{1}{3}$ ,  $n = 10$ ,  $S_{10} = 90\frac{5}{6}$

bo'lsa,  $a_n$  va  $d$  ni toping.

423. Agar arifmetik progressiyada:

1)  $a_7 = 21$ ,  $S_7 = 205$ ;      2)  $a_{11} = 92$ ,  $S_{11} = 22$

bo'lsa,  $a_1$  va  $d$  ni toping.

424. Binobop to'sinlarni saqlashda ularni 75- rasmda ko'rsatilgandek taxlaydilar. Agar taxlamning asosida 12 ta to'sin turgan bo'lsa, bir taxlamda nechta to'sin bo'ladi?

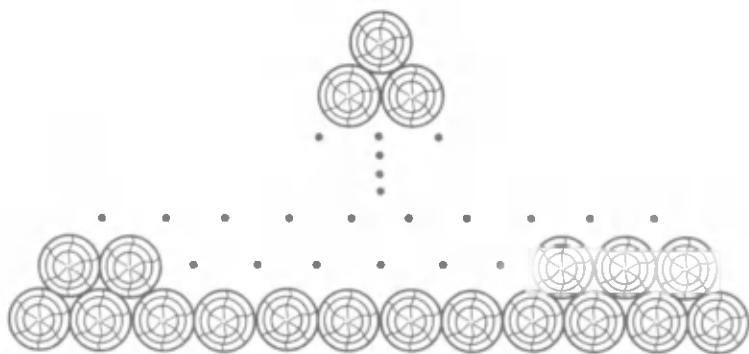

75- rasm.

425. Arifmetik progressiyada  $a_8 + a_9 = 8$ .  $S_{11}$  ni toping.

426. Agar arifmetik progressiyada  $S_5 = 65$  va  $S_{10} = 230$  bo'lsa, uning birinchi hadini va ayirmasini toping.

427. Arifmetik progressiya uchun

$$S_{12} = 3(S_8 - S_4)$$

tenglik bajarilishini isbotlang.

## 32- §.

## GEOMETRIK PROGRESSIYA

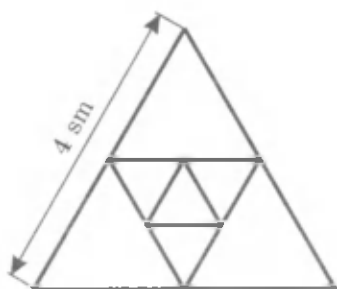

76- rasm.

Tomoni 4 sm bo'lgan teng tomonli muntazam uchburchakni qaraymiz. Uchlari berilgan uchburchak tomonlarining o'rtalaridan iborat bo'lgan uchburchak yasaymiz (76-rasm). Uchburchak o'rta chizig'ining xossasiga ko'ra ikkinchi uchburchakning tomoni 2 sm ga teng. Shunga o'xshash yasashlarni davom ettirib, tomonlari  $1, \frac{1}{2}, \frac{1}{4}$  sm va hokazo bo'lgan uchburchaklarni hosil qilamiz. Shu uchburchaklar tomonlarining uzunliklari ketma-ketligini yozamiz:

$$4, 2, 1, \frac{1}{2}, \frac{1}{4}, \frac{1}{8}, \dots$$

Bu ketma-ketlikda, ikkinchisidan boshlab, uning har bir hadi avvalgi hadni ayni bir xil  $\frac{1}{2}$  songa ko'paytirilganiga teng. Bunday ketma-ketliklar *geometrik progressiyalar* deyiladi.

**Ta'rif.** Agar

$$b_1, b_2, b_3, \dots, b_n, \dots$$

**sonli ketma-ketlikda barcha natural  $n$  uchun**

$$b_{n+1} = b_n q$$

tenglik bajarilsa, bunday ketma-ketlik *geometrik progressiya* deyiladi, bunda  $b_n \neq 0$ ,  $q$  – nolga teng bo'lmagan biror son.

Bu formuladan  $\frac{b_{n+1}}{b_n} = q$  ekanligi kelib chiqadi.  $q$  son *geometrik progressiyaning maxraji* deyiladi.

### Misollar.

- 1) 2, 8, 32, 128, ... – maxraji  $q=4$  bo'lgan geometrik progressiya;
- 2)  $1, \frac{2}{3}, \frac{4}{9}, \frac{8}{27}, \dots$  – maxraji  $q = \frac{2}{3}$  bo'lgan geometrik progressiya;
- 3)  $-\frac{1}{12}, 1, -12, 144, \dots$  – maxraji  $q=-12$  bo'lgan geometrik progressiya;
- 4) 7, 7, 7, 7, ... – maxraji  $q=1$  bo'lgan geometrik progressiya.

**1 - masala.**  $b_n = 7^{2n}$  formula bilan berilgan ketma-ketlik geometrik progressiya bo'lishini isbotlang.

$\triangle$  Barcha  $n$  larda  $b_n = 7^{2n} \neq 0$  ekanligini ta'kidlab o'tamiz.  $\frac{b_{n+1}}{b_n}$  bo'linma barcha  $n$  lar uchun  $n$  ga bog'liq bo'lmagan ayni bir xil songa tengligini isbotlash talab qilinadi. Haqiqatan ham,

$$\frac{b_{n+1}}{b_n} = \frac{7^{2(n+1)}}{7^{2n}} = \frac{7^{2n+2}}{7^{2n}} = 49,$$

ya'ni  $\frac{b_{n+1}}{b_n}$  bo'linma  $n$  ga bog'liq emas.  $\blacktriangle$

Geometrik progressiya ta'rifiga ko'ra

$$b_{n+1} = b_n q, \quad b_{n-1} = \frac{b_n}{q},$$

bundan

$$b_n^2 = b_{n-1} b_{n+1}, \quad n > 1.$$

Agar progressiyaning barcha hadlari musbat bo'lsa, u

 holda  $b_n = \sqrt{b_{n-1} b_{n+1}}$  bo'ladi, ya'ni geometrik progressiyaning ikkinchisidan boshlab har bir hadi unga qo'shni bo'lgan ikkita hadning o'rta geometrigiga teng. «Geometrik» progressiya degan nom shu bilan izohlanadi.

Agar  $b_1$  va  $q$  berilgan bo'lsa, u holda geometrik progressiyaning qolgan hadlarini  $b_{n+1} = b_n q$  rekurrent formula bo'yicha hisoblash mumkinligini ta'kidlaymiz. Biroq,  $n$  katta bo'lganda bu ko'p mehnat talab qiladi. Odatda  $n$ -hadning formulasidan foydalaniladi.

Geometrik progressiyaning ta'rifiga ko'ra

$$b_2 = b_1 q,$$

$$b_3 = b_2 q = b_1 q^2,$$

$$b_4 = b_3 q = b_1 q^3 \text{ va h.k.}$$

Umuman,



$$b_n = b_1 q^{n-1}, \quad (1)$$

chunki geometrik progressiyaning  $n$ - hadi uning birinchi hadini  $q$  songa  $(n-1)$  marta ko'paytirish bilan hosil qilinadi.

(1) formula geometrik progressiya  $n$ -hadi formulasi deyiladi.

**2-masala.** Agar  $b_1 = 81$  va  $q = \frac{1}{3}$  bo'lsa, geometrik progressiya-yettinchi hadini toping.

$\triangle$  (1) formulaga ko'ra:

$$b_7 = 81 \cdot \left(\frac{1}{3}\right)^{7-1} = \frac{81}{3^6} = \frac{1}{9}. \quad \blacktriangle$$

**3-masala.** 486 soni 2, 6, 18, ... geometrik progressiyaning hadi. Shu hadning nomerini toping.

$\triangle$  Aytaylik,  $n$  - izlangan nomer bo'lsin.  $b_1 = 2$ ,  $q = 3$  bo'lgani uchun  $b_n = b_1 q^{n-1}$  formulaga ko'ra:

$$486 = 2 \cdot 3^{n-1}, \quad 243 = 3^{n-1}, \quad 3^5 = 3^{n-1},$$

bundan  $n - 1 = 5$ ,  $n = 6$ .  $\blacktriangle$

**4-masala.** Geometrik progressiyada  $b_6 = 96$  va  $b_8 = 384$ .  $n$ -hadi-ning formulasini toping.

$\triangle$   $b_n = b_1 q^{n-1}$  formulaga ko'ra:  $b_6 = b_1 q^5$ ,  $b_8 = b_1 q^7$ .  $b_6$  va  $b_8$  ning berilgan qiymatlarini qo'yib, hosil qilamiz:  $96 = b_1 q^5$ ,  $384 = b_1 q^7$ . Bu tengliklardan ikkinchisini birinchisiga bo'lamiz:

$$\frac{384}{96} = \frac{b_1 q^7}{b_1 q^5},$$

bundan  $4 = q^2$  yoki  $q^2 = 4$ . Oxirgi tenglikdan  $q = 2$  yoki  $q = -2$  ekanini topamiz.

Progressiyaning birinchi hadini topish uchun  $96 = b_1 q^5$  tenglikdan foydalanamiz:



1)  $q = 2$  bo'lsin. U holda  $96 = b_1 \cdot 2^5$ ,  
 $96 = b_1 \cdot 32$ ,  $b_1 = 3$ .

Demak,  $b_1 = 3$  va  $q = 2$  bo'lganda  $n$ -hadning formulasi

$$b_n = 3 \cdot 2^{n-1}$$

bo'ladi.

2)  $q = -2$  bo'lsin. U holda  $96 = b_1(-2)^5$ ,  
 $96 = b_1(-32)$ ,  $b_1 = -3$ .

Demak,  $b_1 = -3$  va  $q = -2$  bo'lganda,  $n$ -hadning formulasi

$$b_n = -3 \cdot (-2)^{n-1}$$

bo'ladi.

**Javob:**  $b_n = 3 \cdot 2^{n-1}$  yoki  $b_n = -3 \cdot (-2)^{n-1}$ . ▲

**5-masala.** Aylanaga kvadrat ichki chizilgan, unga esa ikkinchi aylana ichki chizilgan. Ikkinchi aylanaga ikkinchi kvadrat ichki chizilgan, unga esa uchinchi aylana ichki chizilgan va hokazo (77-rasm). Aylanalarning radiuslari geometrik progressiya tashkil qilishini isbotlang.

△  $n$ -aylananing radiusi  $r_n$  bo'lsin. U holda Pifagor teoremasiga ko'ra

$$r_{n+1}^2 + r_{n+1}^2 = r_n^2,$$

bundan

$$r_{n+1}^2 = \frac{1}{2} r_n^2, \text{ ya'ni } r_{n+1} = \frac{1}{\sqrt{2}} r_n.$$

Demak, aylanalar radiuslarining ketma-ketligi maxraji  $\frac{1}{\sqrt{2}}$  bo'lgan geometrik progressiya tashkil qiladi. ▲

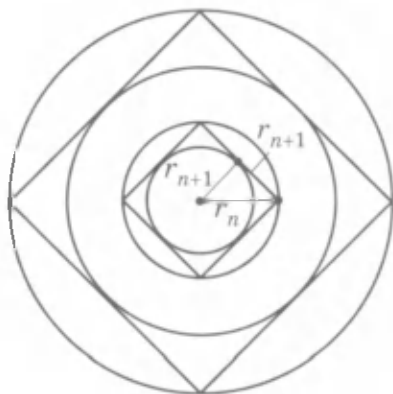

77-rasm.

### Mashqlar

**428.** (Og'zaki.) Ushbu geometrik progressiyaning birinchi hadi va maxraji nimaga teng:

- |                    |                       |
|--------------------|-----------------------|
| 1) 8, 16, 32, ...; | 2) -10, 20, -40, ...; |
| 3) 4, 2, 1, ...;   | 4) -50, 10, -2, ... ? |

**429.** Agar geometrik progressiyada:

- |                           |                          |
|---------------------------|--------------------------|
| 1) $b_1 = 12$ , $q = 2$ ; | 2) $b_1 = -3$ , $q = -4$ |
|---------------------------|--------------------------|

bo'lsa, uning dastlabki beshta hadini yozing.

430.  $n$ -hadining formulasi bilan berilgan quyidagi ketma-ketlik geometrik progressiya bo'lishini isbotlang:

1)  $b_n = 3 \cdot 2^n$ ; 2)  $b_n = 5^{n+3}$ ; 3)  $b_n = \left(\frac{1}{3}\right)^{n-2}$ ; 4)  $b_n = \frac{1}{5^{n-1}}$ .

431. Geometrik progressiyada:

1)  $b_1 = 3$  va  $q = 10$  bo'lsa,  $b_1$  ni;

2)  $b_1 = 4$  va  $q = \frac{1}{2}$  bo'lsa,  $b_7$  ni;

3)  $b_1 = 1$  va  $q = -2$  bo'lsa,  $b_5$  ni;

4)  $b_1 = -3$  va  $q = -\frac{1}{3}$  bo'lsa,  $b_6$  ni hisoblang.

432. Geometrik progressiya  $n$ -hadining formulasini yozing:

1) 4, 12, 36, ...;

2) 3, 1,  $\frac{1}{3}$ , ...;

3) 4, -1,  $\frac{1}{4}$ , ...;

4) 3, -4,  $\frac{16}{3}$ , ... .

433. Geometrik progressiyada tagiga chizilgan hadning nomerini toping:

1) 6, 12, 24, ... , 192, ...;

2) 4, 12, 36, ... , 324, ...;

3) 625, 125, 25, ... ,  $\frac{1}{25}$ ;

4) -1, 2, -4, ... , 128, ... .

434. Agar geometrik progressiyada:

1)  $b_1 = 2$ ,  $b_5 = 162$ ;

3)  $b_1 = -128$ ,  $b_7 = -2$ ;

2)  $b_1 = 3$ ,  $b_4 = 81$ ;

4)  $b_1 = 250$ ,  $b_4 = -2$

bo'lsa, uning maxrajini toping.

435. 2, 6, 18, ... geometrik progressiya berilgan.

1) shu progressiyaning sakkizinchi hadini hisoblang;

2) ketma-ketlikning 162 ga teng hadining nomerini toping.

436. Agar musbat hadli geometrik progressiyada:

1)  $b_8 = \frac{1}{9}$ ,  $b_6 = 81$ ;

2)  $b_6 = 9$ ,  $b_8 = 3$

bo'lsa, uning yettinchi hadini va maxrajini toping.

437. Agar geometrik progressiyada:

1)  $b_4 = 9$ ,  $b_6 = 20$ ;

2)  $b_4 = 9$ ,  $b_6 = 4$

bo'lsa, uning beshinchi va birinchi hadlarini toping.

438. Omonatchi jamg'arma bankiga 2005- yilning 2- yanvar kuni 30 000 so'm pul qo'ydi. Agar jamg'arma banki yiliga jamg'armaning 30%i miqdorida daromad bersa, omonatchining puli 2008- yilning 2- yanvariga borib qancha bo'ladi?
439. Tomoni 4 sm bo'lgan kvadrat berilgan. Uning tomonlarining o'rtachalari ikkinchi kvadratning uchlari bo'ladi. Ikkinchi kvadrat tomonlarining o'rtalari uchinchi kvadratning uchlari bo'ladi va hokazo. Shu kvadratlar yuzlarining ketma-ketligi geometrik progressiya tashkil qilishini isbotlang. Yettinchi kvadratning yuzini toping.

### 33- §.

### GEOMETRIK PROGRESSIYA DASTLABKI n TA HADINING YIG'INDISI

**1- masala.** Ushbu yig'indini toping:

$$S = 1 + 3 + 3^2 + 3^3 + 3^4 + 3^5. \quad (1)$$

△ Tenglikning ikkala qismini 3 ga ko'paytiramiz:

$$3S = 3 + 3^2 + 3^3 + 3^4 + 3^5 + 3^6. \quad (2)$$

(1) va (2) tengliklarni bunday yozib chiqamiz:

$$S = 1 + (3 + 3^2 + 3^3 + 3^4 + 3^5);$$

$$3S = (3 + 3^2 + 3^3 + 3^4 + 3^5) + 3^6.$$

Qavslarning ichida turgan ifodalar bir xil. Shuning uchun pastdagi tenglikdan yuqoridagi tenglikni ayirib, hosil qilamiz:

$$3S - S = 3^6 - 1, \quad 2S = 3^6 - 1,$$

$$S = \frac{3^6 - 1}{2} = \frac{729 - 1}{2} = 364. \quad \blacktriangle$$

Endi maxraji  $q \neq 1$  bo'lgan ixtiyoriy  $b_1, b_1q, \dots, b_1q^n, \dots$  geometrik progressiyani qaraymiz.  $S_n$  - shu progressiyaning dastlabki  $n$  ta hadining yig'indisi bo'lsin:

$$S_n = b_1 + b_1q + b_1q^2 + \dots + b_1q^{n-1}. \quad (3)$$

**Teorema.** Maxraji  $q \neq 1$  bo'lgan geometrik progressiyaning dastlabki  $n$  ta hadining yig'indisi quyidagiga teng:

$$S_n = \frac{b_1(1 - q^n)}{1 - q}. \quad (4)$$

○ (3) tenglikning ikkala qismini  $q$  ga ko'paytiramiz:

$$qS_n = b_1q + b_1q^2 + b_1q^3 + \dots + b_1q^n. \quad (5)$$

(3) va (5) tengliklarni, ulardagi bir xil qo'shiluvchilarni ajratib, yozib chiqamiz:

$$S_n = b_1 + (b_1q + b_1q^2 + \dots + b_1q^{n-1}),$$

$$qS_n = (b_1q + b_1q^2 + b_1q^3 + \dots + b_1q^{n-1}) + b_1q^n.$$

Qavslarning ichida turgan ifodalar teng. Shuning uchun yuqoridagi tenglikdan pastdagisini ayirib, hosil qilamiz:

$$S_n - qS_n = b_1 - b_1q^n.$$

Bundan

$$S_n(1 - q) = b_1(1 - q^n), \quad S_n = \frac{b_1(1 - q^n)}{1 - q}. \quad \bullet$$

Agar  $q = 1$  bo'lsa, u holda

$$S_n = \underbrace{b_1 + b_1 + \dots + b_1}_{n \text{ ta qo'shiluvchi}} = b_1n, \quad \text{ya'ni } S_n = b_1n.$$

**2-masala.** 6, 2,  $\frac{2}{3}$ , ... geometrik progressiya dastlabki beshta hadining yig'indisini toping.

△ Bu progressiyada  $b_1 = 6$ ,  $q = \frac{1}{3}$ . (4) formula bo'yicha topamiz:

$$S_5 = \frac{6 \cdot \left(1 - \left(\frac{1}{3}\right)^5\right)}{1 - \frac{1}{3}} = \frac{6 \cdot \left(1 - \frac{1}{243}\right)}{\frac{2}{3}} = \frac{6 \cdot 242 \cdot 3}{2 \cdot 243} = \frac{242}{27}. \quad \blacktriangle$$

**3-masala.** Maxraji  $q = \frac{1}{2}$  bo'lgan geometrik progressiyada dastlabki oltita hadning yig'indisi 252 ga teng. Shu progressiyaning birinchi hadini toping.

△ (4) formuladan foydalanib, hosil qilamiz:

$$252 = \frac{b_1 \left(1 - \frac{1}{2^6}\right)}{1 - \frac{1}{2}}.$$

Bundan  $252 = 2b_1 \left(1 - \frac{1}{64}\right)$ ,  $252 = \frac{b_1 \cdot 63}{32}$ ,  $b_1 = 128$ .  $\blacktriangle$

**4 - masala.** Geometrik progressiya dastlabki  $n$  ta hadining yig'indisi  $-93$  ga teng. Bu progressiyaning birinchi hadi  $-3$  ga, maxraji esa  $2$  ga teng.  $n$  ni toping.

△ (4) formuladan foydalanib, hosil qilamiz:

$$-93 = \frac{-3(1-2^n)}{1-2}.$$

Bundan  $-31 = 1 - 2^n$ ,  $2^n = 32$ ,  $2^5 = 2^n$ ,  $n = 5$ . ▲

**5 - masala.**  $5, 15, 45, \dots, 1215, \dots$  – geometrik progressiya.  $5 + 15 + 45 + \dots + 1215$  yig'indini toping.

△ Bu progressiyada  $b_1 = 5$ ,  $q = 3$ ,  $b_n = 1215$ . Dastlabki  $n$  ta had yig'indisi formulasini bunday almashtiramiz:

$$S_n = \frac{b_1(1-q^n)}{1-q} = \frac{b_1 - b_1q^{n-1}q}{1-q} = \frac{b_1 - b_nq}{1-q} = \frac{b_nq - b_1}{q-1}.$$

Masalaning shartidan foydalanib, topamiz:

$$S_n = \frac{1215 \cdot 3 - 5}{3-1} = \frac{3645-5}{2} = 1820. \quad \blacktriangle$$

### *Mashqlar*

**440.** Agar geometrik progressiyada:

- |   |  |
|---|--|
| 1) $b_1 = \frac{1}{2}$ , $q = 2$ , $n = 6$ ;  | 2) $b_1 = -2$ , $q = \frac{1}{2}$ , $n = 5$ ;  |
| 3) $b_1 = 1$ , $q = -\frac{1}{3}$ , $n = 4$ ; | 4) $b_1 = -5$ , $q = -\frac{2}{3}$ , $n = 5$ ; |
| 5) $b_1 = 6$ , $q = 1$ , $n = 200$ ;          | 6) $b_1 = -4$ , $q = 1$ , $n = 100$            |

bo'lsa, uning dastlabki  $n$  ta hadining yig'indisini toping.

**441.** Geometrik progressiya dastlabki yettita hadining yig'indisini toping:

- |                         |                        |
|-------------------------|------------------------|
| 1) $5, 10, 20, \dots$ ; | 2) $2, 6, 18, \dots$ . |
|-------------------------|------------------------|

**442.** Agar geometrik progressiyada:

- 1)  $q = 2$ ,  $S_7 = 635$  bo'lsa,  $b_1$  va  $b_7$  ni toping;
- 2)  $q = -2$ ,  $S_8 = 85$  bo'lsa,  $b_1$  va  $b_8$  ni toping.

**443.** Agar geometrik progressiyada:

1)  $S_n = 189$ ,  $b_1 = 3$ ,  $q = 2$ ;

2)  $S_n = 635$ ,  $b_1 = 5$ ,  $q = 2$ ;

3)  $S_n = 170$ ,  $b_1 = 256$ ,  $q = -\frac{1}{2}$ ;

4)  $S_n = -99$ ,  $b_1 = -9$ ,  $q = -2$

bo'lsa, uning hadlari soni  $n$  ni toping.

**444.** Agar geometrik progressiyada:

1)  $b_1 = 7$ ,  $q = 3$ ,  $S_n = 847$  bo'lsa,  $n$  va  $b_n$  ni;

2)  $b_1 = 8$ ,  $q = 2$ ,  $S_n = 4088$  bo'lsa,  $n$  va  $b_n$  ni;

3)  $b_1 = 2$ ,  $b_n = 1458$ ,  $S_n = 2186$  bo'lsa,  $n$  va  $q$  ni;

4)  $b_1 = 1$ ,  $b_n = 2401$ ,  $S_n = 2801$  bo'lsa,  $n$  va  $q$  ni toping.

**445.** Agar sonlar yig'indisining qo'shiluvchilari geometrik progressiyaning ketma-ket hadlari bo'lsa, shu yig'indini toping:

1)  $1 + 2 + 4 + \dots + 128$ ;                      2)  $1 + 3 + 9 + \dots + 243$ ;

3)  $-1 + 2 - 4 + \dots + 128$ ;                      4)  $5 - 15 + 45 - \dots + 405$ .

**446.** Agar geometrik progressiyada:

1)  $b_2 = 15$ ,  $b_3 = 25$ ;                      2)  $b_2 = 14$ ,  $b_4 = 686$ ,  $q > 0$  bo'lsa,  $b_5$  va  $S_4$  ni toping.

**447.** Geometrik progressiya  $n$ -hadining formulasi bilan berilgan:

1)  $b_n = 3 \cdot 2^{n-1}$  bo'lsa,  $S_5$  ni toping;

2)  $b_n = -2\left(\frac{1}{2}\right)^n$  bo'lsa,  $S_6$  ni toping.

**448.** Ayniyatni isbotlang:

$$(x - 1)(x^{n-1} + x^{n-2} + \dots + 1) = x^n - 1,$$

bunda  $n$  daraja ko'rsatkichi va  $u$  1 dan katta natural son.

**449.** Geometrik progressiyada:

1)  $b_3 = 135$ ,  $S_3 = 195$  bo'lsa,  $b_1$  va  $q$  ni toping;

2)  $b_1 = 12$ ,  $S_3 = 372$  bo'lsa,  $q$  va  $b_3$  ni toping.

**450.** Geometrik progressiyada:

- 1)  $b_1 = 1$  va  $b_3 + b_5 = 90$  bo'lsa,  $q$  ni;
- 2)  $b_2 = 3$  va  $b_4 + b_6 = 60$  bo'lsa,  $q$  ni;
- 3)  $b_1 - b_3 = 15$  va  $b_2 - b_4 = 30$  bo'lsa,  $S_{10}$  ni;
- 4)  $b_3 - b_1 = 24$  va  $b_5 - b_1 = 624$  bo'lsa,  $S_5$  ni toping.

**34- §.**

**CHEKSIZ KAMAYUVCHI  
GEOMETRIK PROGRESSIYA**

78- rasmda tasvirlangan kvadratlarni qaraymiz. Birinchi kvadratning tomoni 1 ga teng, ikkinchisidiki  $\frac{1}{2}$  ga, uchinchisidiki esa  $\frac{1}{2^2}$  ga teng va hokazo. Shunday qilib, kvadratning tomonlari maxraji  $\frac{1}{2}$  bo'lgan quyidagi geometrik progressiyani tashkil qiladi:

$$1, \frac{1}{2}, \frac{1}{2^2}, \frac{1}{2^3}, \dots, \frac{1}{2^{n-1}}, \dots \quad (1)$$

Bu kvadratlarining yuzlari esa maxraji  $\frac{1}{4}$  bo'lgan ushbu geometrik progressiyani tashkil qiladi:

$$1, \frac{1}{4}, \frac{1}{4^2}, \frac{1}{4^3}, \dots, \frac{1}{4^{n-1}}, \dots \quad (2)$$

78- rasmdan ko'rinib turibdiki, kvadratlarining tomonlari va ularning yuzlari  $n$  nomerning ortishi bilan borgan sari kamayib, nolga yaqinlasha boradi. Shuning uchun (1) va (2) progressiyalar cheksiz kamayuvchi progressiyalar deyiladi. Bu progressiyalarning maxrajilari birdan kichik ekanligini ta'kidlab o'tamiz.

Endi quyidagi geometrik progressiyani qaraymiz:

$$1, -\frac{1}{3}, \frac{1}{3^2}, -\frac{1}{3^3}, \dots, \frac{(-1)^{n-1}}{3^{n-1}}, \dots \quad (3)$$

Bu progressiyaning maxraji  $q = -\frac{1}{3}$ , hadlari esa  $b_1 = 1, b_2 = -\frac{1}{3}, b_3 = \frac{1}{9}, b_4 = -\frac{1}{27}$  va hokazo.

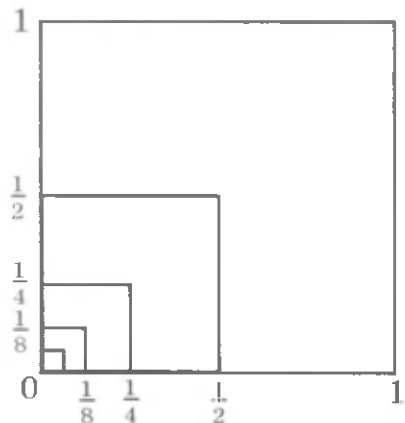

78- rasm.

$n$  nomerning ortishi bilan bu progressiyaning hadlari nolga yaqinlashadi. (3) progressiya ham *cheksiz kamayuvchi progressiya* deyiladi. Uning maxrajining moduli birdan kichik ekanligini ta'kidlab o'tamiz:  $|q| < 1$ .



**Maxrajining moduli birdan kichik bo'lgan geometrik progressiya cheksiz kamayuvchi geometrik progressiya deyiladi.**

**1 - masala.**  $n$ -hadining  $b_n = \frac{3}{5^n}$  formulasi bilan berilgan geometrik progressiya cheksiz kamayuvchi bo'lishini isbotlang.

△ Shartga ko'ra  $b_1 = \frac{3}{5}$ ,  $b_2 = \frac{3}{5^2} = \frac{3}{25}$ , bundan  $q = \frac{b_2}{b_1} = \frac{1}{5}$ .  $|q| < 1$  bo'lgani uchun berilgan geometrik progressiya cheksiz kamayuvchi bo'ladi. ▲

79- rasmda tomoni 1 bo'lgan kvadrat tasvirlangan. Uning yarmini shtrixlaymiz. So'ngra qolgan qismining yarmini shtrixlaymiz va hokazo. Shtrixlangan to'g'ri to'rtburchaklarning yuzlari quyidagi cheksiz kamayuvchi geometrik progressiyani tashkil qiladi:

$$\frac{1}{2}, \frac{1}{4}, \frac{1}{8}, \frac{1}{16}, \frac{1}{32}, \dots$$

Agar shunday yo'l bilan hosil qilingan barcha to'g'ri to'rtburchaklarni shtrixlab chiqsak, u holda butun kvadrat shtrix bilan qoplanadi. Hamma shtrixlangan to'g'ri to'rtburchaklar yuzlarining yig'indisini 1 ga teng deb hisoblash tabiiydir, ya'ni:

$$\frac{1}{2} + \frac{1}{4} + \frac{1}{8} + \frac{1}{16} + \frac{1}{32} + \dots = 1.$$

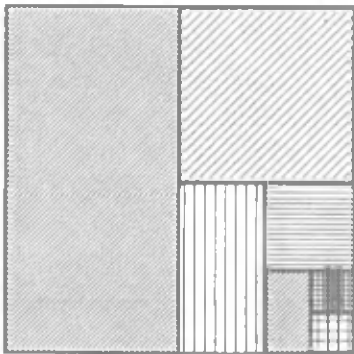

79- rasm.

Bu tenglikning chap qismida cheksiz sondagi qo'shiluvchilar yig'indisi turibdi. Dastlabki  $n$  ta qo'shiluvchining yig'indisini qaraymiz:

$$S_n = \frac{1}{2} + \frac{1}{4} + \frac{1}{8} + \dots + \frac{1}{2^n}.$$

Geometrik progressiya dastlabki  $n$  ta hadi yig'indisi formulasiga ko'ra:

$$S_n = \frac{1}{2} \cdot \frac{1 - \left(\frac{1}{2}\right)^n}{1 - \frac{1}{2}} = 1 - \frac{1}{2^n}.$$



Agar  $n$  cheksiz o'sib borsa, u holda  $\frac{1}{2^n}$  nolga istagancha yaqinlasha boradi (nolga intiladi). Bunday hol quyidagicha yoziladi:

$$n \rightarrow \infty \text{ da } \frac{1}{2^n} \rightarrow 0$$

(o'qilishi:  $n$  cheksizlikka intilganda  $\frac{1}{2^n}$  nolga intiladi) yoki

$$\lim_{n \rightarrow \infty} \frac{1}{2^n} = 0$$

(o'qilishi:  $n$  cheksizlikka intilganda  $\frac{1}{2^n}$  ketma-ketlikning limiti nolga teng).

Umuman, biror  $a_n$  ketma-ketlik uchun  $n \rightarrow \infty$  da  $a_n - a \rightarrow 0$  bo'lsa, u holda  $a_n$  ketma-ketlik  $a$  songa intiladi ( $a_n$  ketma-ketlikning  $n \rightarrow \infty$  dagi limiti  $a$  ga teng) deyiladi va bu  $\lim_{n \rightarrow \infty} a_n = a$  kabi yoziladi.

$n \rightarrow \infty$  da  $\frac{1}{2^n} \rightarrow 0$  bo'lgani uchun  $n \rightarrow \infty$  da  $\left(1 - \frac{1}{2^n}\right) \rightarrow 1$ , ya'ni  $n \rightarrow \infty$  da  $S_n \rightarrow 1$ . Shuning uchun  $\frac{1}{2} + \frac{1}{4} + \frac{1}{8} + \frac{1}{16} + \frac{1}{32} + \dots$  cheksiz yig'indi 1 ga teng deb hisoblanadi.

Endi ixtiyoriy cheksiz kamayuvchi geometrik progressiyani qaraymiz:

$$b_1, b_1q, b_1q^2, \dots, b_1q^{n-1}, \dots,$$

bunda  $|q| < 1$ .

***Cheksiz kamayuvchi geometrik progressiyaning yig'indisi deb  $n \rightarrow \infty$  da uning dastlabki  $n$  ta hadi yig'indisi intiladigan songa aytiladi.***

$S_n = \frac{b_1(1-q^n)}{1-q}$  formuladan foydalanamiz. Uni bunday yozamiz:

$$S_n = \frac{b_1}{1-q} - \frac{b_1}{1-q} q^n. \quad (4)$$

Agar  $n$  cheksiz o'ssa,  $|q| < 1$  bo'lgani uchun  $q^n \rightarrow 0$ . Shuning uchun  $\frac{b_1}{1-q} \cdot q^n$  ham  $n \rightarrow \infty$  da nolga intiladi. (4) formulada birinchi qo'shiluvchi  $n$  ga bog'liq emas. Demak,  $n \rightarrow \infty$  da  $S_n$  yig'indi  $\frac{b_1}{1-q}$  songa intiladi.

**Shunday qilib, cheksiz kamayuvchi geometrik progressiya-ning  $S$  yig'indisi quyidagiga teng:**



$$S = \frac{b_1}{1-q}. \quad (5)$$

**Xususiyl holda,  $b_1 = 1$  bo'lganda,  $S = \frac{1}{1-q}$  ni olamiz. Bu tenglik odatda ushbu ko'rinishda yoziladi:**

$$1 + q + q^2 + \dots + q^{n-1} + \dots = \frac{1}{1-q}.$$

Bu tenglik va (5) tenglik faqat  $|q| < 1$  bo'lganda o'rinli bo'lishini ta'kidlab o'tamiz.

**2-masala.**  $\frac{1}{2}, -\frac{1}{6}, \frac{1}{18}, -\frac{1}{54}, \dots$  cheksiz kamayuvchi geometrik progressiya yig'indisini toping.

$\triangle$   $b_1 = \frac{1}{2}, b_2 = -\frac{1}{6}$  bo'lgani uchun  $q = \frac{b_2}{b_1} = -\frac{1}{3}, S = \frac{b_1}{1-q}$  formula bo'yicha:

$$S = \frac{\frac{1}{2}}{1 - \left(-\frac{1}{3}\right)} = \frac{3}{8}. \blacktriangle$$

**3-masala.** Agar  $b_3 = -1, q = \frac{1}{7}$  bo'lsa, cheksiz kamayuvchi geometrik progressiya yig'indisini toping.

$\triangle$   $n = 3$  bo'lganda  $b_n = b_1 q^{n-1}$  formulani qo'llasak,  $-1 = b_1 \cdot \left(\frac{1}{7}\right)^{3-1}$ ,  $-1 = b_1 \cdot \frac{1}{49}$  hosil bo'ladi, bundan  $b_1 = -49$ .

(5) formula bo'yicha  $S$  yig'indini topamiz:

$$S = \frac{-49}{1 - \frac{1}{7}} = -57 \frac{1}{6}. \blacktriangle$$

**4-masala.** (5) formuladan foydalanib,  $a = 0,(15) = 0,151515\dots$  cheksiz o'nli davriy kasrni oddiy kasr shaklida yozing.

$\triangle$  Berilgan cheksiz kasr taqribiy qiymatlarining quyidagi ketma-ketligini tuzamiz:

$$a_1 = 0,15 = \frac{15}{100},$$

$$a_2 = 0,1515 = \frac{15}{100} + \frac{15}{100^2},$$

$$a_3 = 0,151515 = \frac{15}{100} + \frac{15}{100^2} + \frac{15}{100^3}.$$

Taqribiy qiymatlarni bunday yozish berilgan davriy kasrni cheksiz kamayuvchi geometrik progressiya yig'indisi shaklida tasvirlash mumkinligini ko'rsatadi:

$$a = \frac{15}{100} + \frac{15}{100^2} + \frac{15}{100^3} + \dots$$

(5) formulaga ko'ra:

$$a = \frac{\frac{15}{100}}{1 - \frac{1}{100}} = \frac{15}{99} = \frac{5}{33} \cdot \blacktriangle$$

### Mashqlar

**451.** Ushbu geometrik progressiya cheksiz kamayuvchi bo'lishini isbotlang:

- 1)  $1, \frac{1}{2}, \frac{1}{4}, \dots$ ;      2)  $\frac{1}{3}, \frac{1}{9}, \frac{1}{27}, \dots$ ;  
 3)  $-81, -27, -9, \dots$ ;      4)  $-16, -8, -4, \dots$

**452.** Agar geometrik progressiyada:

- 1)  $b_1 = 40, b_2 = -20$ ;      2)  $b_7 = 12, b_{11} = \frac{3}{4}$ ;  
 3)  $b_7 = -30, b_6 = 15$ ;      4)  $b_5 = -9, b_9 = -\frac{1}{27}$

bo'lsa, u cheksiz kamayuvchi bo'ladimi? Shuni aniqlang.

**453.** Cheksiz kamayuvchi geometrik progressiya yig'indisini toping:

- 1)  $1, \frac{1}{3}, \frac{1}{9}, \dots$ ;      2)  $6, 1, \frac{1}{6}, \dots$ ;  
 3)  $-25, -5, -1, \dots$ ;      4)  $-7, -1, -\frac{1}{7}, \dots$

**454.** Agar cheksiz kamayuvchi geometrik progressiyada:

- 1)  $q = \frac{1}{2}, b_1 = \frac{1}{8}$ ;      2)  $q = -\frac{1}{3}, b_1 = 9$ ;  
 3)  $q = \frac{1}{3}, b_5 = \frac{1}{81}$ ;      4)  $q = -\frac{1}{2}, b_4 = -\frac{1}{8}$

bo'lsa, uning yig'indisini toping.

455.  $n$ -hadining formulasi bilan berilgan quyidagi ketma-ketlik cheksiz kamayuvchi geometrik progressiya bo'la oladimi?

1)  $b_n = 3 \cdot (-2)^n$ ;                      2)  $b_n = -3 \cdot 4^n$ ;

3)  $b_n = 2 \cdot \left(-\frac{1}{3}\right)^{n-1}$ ;                      4)  $b_n = 5 \cdot \left(-\frac{1}{2}\right)^{n-1}$

456. Cheksiz kamayuvchi geometrik progressiya yig'indisini toping:

1) 12, 4,  $\frac{4}{3}$ , ...;                      2) 100, -10, 1 ...

457. Agar cheksiz kamayuvchi geometrik progressiyada:

1)  $q = \frac{1}{2}$ ,  $b_5 = \frac{\sqrt{2}}{16}$ ;                      2)  $q = \frac{\sqrt{3}}{2}$ ,  $b_4 = \frac{9}{8}$

bo'lsa, uning yig'indisini toping.

458. Cheksiz kamayuvchi geometrik progressiyaning yig'indisi 150 ga teng. Agar:

1)  $q = \frac{1}{3}$  bo'lsa,  $b_1$  ni;                      2)  $b_1 = 75$  bo'lsa,  $q$  ni toping.

459. Qirradi  $a$  bo'lgan kubning ustiga qirradi  $\frac{a}{2}$  bo'lgan kub qo'yishdi, uning ustiga qirradi  $\frac{a}{4}$  bo'lgan kub qo'yishdi, so'ngra uning ustiga qirradi  $\frac{a}{8}$  bo'lgan kub qo'yishdi va hokazo (80-rasm). Hosil bo'lgan shaklning balandligini toping.

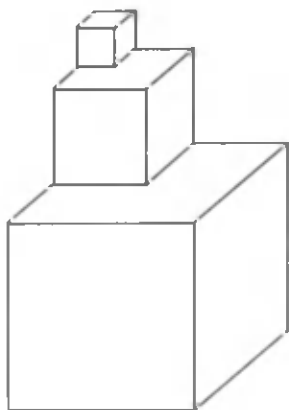

80- rasm.

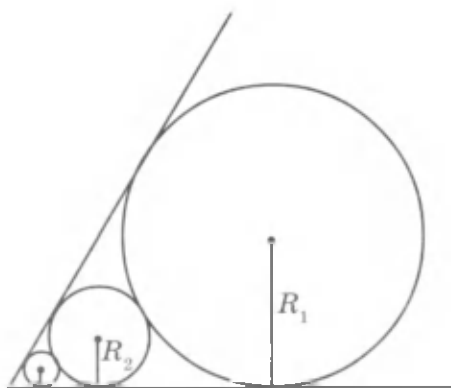

81- rasm.

**460.**  $60^\circ$  li burchakka bir-biriga urinuvchi aylanalarning ketma-ket ichki chizilgan (81-rasm). Birinchi aylananing radiusi  $R_1$  ga teng. Qolgan aylanalarning  $R_2, R_3, \dots, R_n, \dots$  radiuslarini toping va ular cheksiz kamayuvchi geometrik progressiya tashkil qilishini ko'rsating.  $R_1 + 2(R_2 + R_3 + \dots + R_n + \dots)$  yig'indi birinchi aylananing markazidan burchakning uchigacha bo'lgan masofaga tengligini isbotlang.

**461.** Cheksiz davriy o'nli kasrni oddiy kasr shaklida yozing:  
 1) 0,(5);    2) 0,(9);    3) 0,(12);    4) 0,2(3).

### VI bobga doir mashqlar

**462.** Arifmetik progressiyaning ayirmasini toping, uning to'rtinchi va beshinchi hadlarini yozing:

1)  $4, 4\frac{1}{3}, 4\frac{2}{3}, \dots;$

2)  $3\frac{1}{2}, 3, 2\frac{1}{2}, \dots;$

3)  $1, 1 + \sqrt{3}, 1 + 2\sqrt{3}, \dots;$

4)  $\sqrt{2}, \sqrt{2} - 3, \sqrt{2} - 6, \dots$

**463.**  $n$ -hadi  $a_n = -2(1 - n)$  formula bilan berilgan ketma-ketlik arifmetik progressiya bo'lishini isbotlang.

**464.** Agar arifmetik progressiyada:

1)  $a_1 = 6, d = \frac{1}{2}$  bo'lsa,  $a_5$  ni hisoblang;

2)  $a_1 = -3\frac{1}{3}, d = -\frac{1}{3}$  bo'lsa,  $a_7$  ni hisoblang.

**465.** Agar arifmetik progressiyada:

1)  $a_1 = -1, a_2 = 1;$

2)  $a_1 = 3, a_2 = -3$

bo'lsa, uning dastlabki yigirmata hadining yig'indisini toping.

**466.** Agar arifmetik progressiyada:

1)  $a_1 = -2, a_n = -60, n = 10;$

2)  $a_1 = \frac{1}{2}, a_n = 25\frac{1}{2}, n = 11$

bo'lsa, uning dastlabki  $n$  ta hadining yig'indisini toping.

**467.** Agar:

1)  $-38 + (-33) + (-28) + \dots + 12;$     2)  $-17 + (-14) + (-11) + \dots + 13$   
 yig'indining qo'shiluvchilari arifmetik progressiyaning ketma-ket hadlari bo'lsa, shu yig'indini toping.

468. Geometrik progressiyaning maxrajini toping hamda uning to'rtinchi va beshinchi hadlarini yozing:

1)  $3, 1, \frac{1}{3}, \dots$ ;

2)  $\frac{1}{4}, -\frac{1}{8}, \frac{1}{16}, \dots$ ;

3)  $3, \sqrt{3}, 1, \dots$ ;

4)  $5, -5\sqrt{2}, 10, \dots$  .

469. Geometrik progressiyaning  $n$ -hadi formulasini yozing:

1)  $-2, 4, -8, \dots$ ;

2)  $-\frac{1}{2}, 1, -2, \dots$

470. Agar geometrik progressiyada:

1)  $b_1 = 2, q = 2, n = 6$ ;

2)  $b_1 = \frac{1}{8}, q = 5, n = 4$

bo'lsa,  $b_n$  ni toping.

471. Agar geometrik progressiyada:

1)  $b_1 = \frac{1}{2}, q = -4, n = 5$ ;

2)  $b_1 = 2, q = -\frac{1}{2}, n = 10$ ;

3)  $b_1 = 10, q = 1, n = 6$ ;

4)  $b_1 = 5, q = -1, n = 9$

bo'lsa, uning dastlabki  $n$  ta hadining yig'indisini toping.

472. Geometrik progressiyaning dastlabki  $n$  ta hadining yig'indisini toping:

1)  $128, 64, 31, \dots, n = 6$ ;

2)  $162, 54, 18, \dots, n = 5$ ;

3)  $\frac{2}{3}, \frac{1}{2}, \frac{3}{8}, \dots, n = 5$ ;

4)  $\frac{3}{4}, \frac{1}{2}, \frac{1}{3}, \dots, n = 4$ .

473. Berilgan geometrik progressiya cheksiz kamayuvchi ekanligini isbotlang va uning yig'indisini toping:

1)  $-\frac{1}{2}, -\frac{1}{4}, \frac{1}{8}, \dots$ ;

2)  $-1, \frac{1}{4}, -\frac{1}{16}, \dots$  .

474. Agar arifmetik progressiyada  $a_1 = 2\frac{1}{2}$  va  $a_8 = 23\frac{1}{2}$  bo'lsa, uning ayirmasini toping.

475. Agar arifmetik progressiyada:

1)  $a_1 = 5, a_3 = 15$ ;

2)  $a_3 = 8, a_5 = 2$

bo'lsa, uning dastlabki beshta hadini yozing.

476.  $-10$  va  $5$  sonlari orasiga bitta sonni shunday qo'yingki, natijada arifmetik progressiyaning ketma-ket uchta hadi hosil bo'lsin.

477. Agar arifmetik progressiyada:

1)  $a_{13} = 28, a_{20} = 38$ ;

2)  $a_{18} = -6, a_{20} = 6$

bo'lsa, uning  $o'n$  to'qqizinchi va birinchi hadlarini toping.

### O'ZINGIZNI TEKSHIRIB KO'RING!

1. Arifmetik progressiyada  $a_1 = 2$ ,  $d = -3$ .  $a_{10}$  ni va dastlabki o'nta hadning yig'indisini toping.
2. Geometrik progressiyada  $b_1 = 4$ ,  $q = \frac{1}{2}$ .  $b_6$  ni va dastlabki oltita hadning yig'indisini toping.
3.  $1, \frac{1}{3}, \frac{1}{9}, \dots$  ketma-ketlik cheksiz kamayuvchi geometrik progressiya ekanligini isbotlang va uning hadlari yig'indisini toping.

478.  $x$  ning qanday qiymatlarida:

1)  $3x, \frac{x+2}{2}, 2x-1$ ;

2)  $3x^2, 2, 11x$

sonlar arifmetik progressiyaning ketma-ket hadlari bo'ladi?

479. Quyidagi sonlar arifmetik progressiyaning ketma-ket uchta hadi bo'lishini ko'rsating:

1)  $\sin(\alpha + \beta), \sin\alpha\cos\beta, \sin(\alpha - \beta)$ ;      2)  $\cos(\alpha + \beta), \cos\alpha\cos\beta, \cos(\alpha - \beta)$ ;

3)  $\cos 2\alpha, \cos^2\alpha, 1$ ;      4)  $\sin 5\alpha, \sin 3\alpha\cos 2\alpha, \sin\alpha$ .

480. Yig'indi 252 ga teng bo'lishi uchun 5 dan boshlab nechta ketma-ket toq natural sonni qo'shish kerak?

481. Agar arifmetik progressiyada:

1)  $a_1 = 40, n = 20, S_{20} = -40$ ;

2)  $a_1 = \frac{1}{3}, n = 16, S_{16} = -10\frac{2}{3}$  bo'lsa,  $a_n$  va  $d$  ni toping.

482. Geometrik progressiyada:

1) agar  $b_1 = 4$  va  $q = -1$  bo'lsa,  $b_9$  ni hisoblang;

2) agar  $b_1 = 1$  va  $q = \sqrt{3}$  bo'lsa,  $b_7$  ni hisoblang.

483. Agar geometrik progressiyada:

1)  $b_2 = \frac{1}{2}, b_7 = 16$ ;      2)  $b_3 = -3, b_6 = -81$ ;

3)  $b_2 = 4, b_4 = 1$ ;      4)  $b_4 = -\frac{1}{5}, b_6 = -\frac{1}{125}$

bo'lsa, uning beshinchi hadini toping.

484. 4 va 9 sonlari orasiga bitta musbat sonni shunday qo'yingki, natijada geometrik progressiyaning ketma-ket uchta hadi hosil bo'lsin.

485. Agar ketma-ketlik  $n$ -hadining:

$$1) b_n = 5^{n+1}; \quad 2) b_n = (-4)^{n+2}; \quad 3) b_n = \frac{10}{7^n}; \quad 4) b_n = -\frac{50}{3^{n+3}}$$

formulasi bilan berilgan bo'lsa, u cheksiz kamayuvchi geometrik progressiya bo'la oladimi?

486. Agar geometrik progressiyada:

$$1) b_2 = -81, S_2 = 162; \quad 2) b_2 = 33, S_2 = 67;$$

$$3) b_1 + b_3 = 130, b_1 - b_3 = 120; \quad 4) b_2 + b_4 = 68, b_2 - b_4 = 60$$

bo'lsa, u cheksiz kamayuvchi ekanligini ko'rsating.

487. Dam oluvchi shifokor tavsiyasiga amal qilib, birinchi kuni Quyosh nurida 5 minut toblandi, keyingi har bir kunda esa toblanishni 5 min dan oshirib bordi. Agar u toblanishni chorshanba kundan boshlagan bo'lsa, haftaning qaysi kuni uning Quyoshda toblanishi 40 min ga teng bo'ladi?

488. Agar arifmetik progressiyada  $a_1 + a_2 + a_3 = 15$  va  $a_1 \cdot a_2 \cdot a_3 = 80$  bo'lsa, uning birinchi hadi va ayirmasini toping.

489. Agar arifmetik progressiyada  $a_1 + a_2 + a_3 = 0$  va  $a_1^2 + a_2^2 + a_3^2 = 50$  bo'lsa, uning birinchi hadi va ayirmasini toping.

490. Soat 1 da soat 1 marta, 2 da 2 marta, ..., 12 da 12 marta bong uradi. Soat mili navbatdagi har soatning yarmini ko'rsatganda esa bir marta bong uradi. Bu soat bir sutkada necha marta bong uradi?

?

### VI bobga doir sinov (test) mashqlari

1. Arifmetik progressiyada  $a_1 = 3$ ,  $d = -2$ .  $S_{101}$  ni toping.

A) -9797; B) -9798; C) -7979; D) -2009; E) -9697.

2. Arifmetik progressiyada  $d = 4$ ,  $S_{50} = 5000$  bo'lsa,  $a_1$  ni toping.

A) -2; B) 2; C) 100; D) 1250; E) 5.

3. Arifmetik progressiyada  $a_1 = 1$ ,  $a_{101} = 301$  bo'lsa,  $d$  ni toping.

A) 4; B) 2; C) 3; D) 3,5; E) 5.

4. Arifmetik progressiyada  $a_2 + a_4 = 20$  bo'lsa,  $S_{10}$  ni toping.

A) 90; B) 110; C) 200; D) 100; E) aniqlab bo'lmaydi.



5. 8 ga bo'lganda 7 qoldiq beradigan ketma-ketlikning 5- hadini belgilang.  
A) 74; B) 55; C) 39; D) 63; E) 47.
6. 701 soni 1, 8, 15, 22, ... progressiyaning nechanchi nomerli hadi?  
A) 101; B) 100; C) 102; D) 99; E) bu progressiyaning hadi emas.
7. 1002, 999, 996, ... progressiyaning nechanchi nomerli hadidan boshlab, uning hadlari manfiy sonlar bo'ladi?  
A) 335; B) 336; C) 337; D) 334; E) 330.
8. Arifmetik progressiyada  $a_2 + a_6 = 44$ ,  $a_5 - a_1 = 20$  bo'lsa,  $a_{100}$  ni toping.  
A) 507; B) 495; C) 502; D) 595; E) 520.
9. Arifmetik progressiyada  $a_1 = 7$ ,  $d = 5$ ,  $S_n = 25450$  bo'lsa,  $n$  ni toping.  
A) 99; B) 101; C) 10; D) 100; E) 590.
10. Arifmetik progressiya  $a_{12} + a_{15} = 20$  bo'lsa,  $S_{26}$  ni toping.  
A) 540; B) 270; C) 520; D) 130; E) 260.
11. 1 va 11 sonlari orasida 99 ta shunday sonni joylashtiringki, ular bu sonlar bilan birgalikda arifmetik progressiya tashkil qilsin. Shu progressiya uchun  $S_{50}$  ni toping.  
A)  $172\frac{1}{2}$ ; B) 495; C) 300; D) 178; E) 345.
12. Arifmetik progressiyada  $a_1 = -20,7$ ,  $d = 1,8$  bo'lsa, qaysi nomerli haddan boshlab progressiyaning barcha hadlari musbat bo'ladi?  
A) 18; B) 13; C) 12; D) 15; E) 17.
13. 7 ga karrali dastlabki nechta natural sonni qo'shganda 385 hosil bo'ladi?  
A) 12; B) 11; C) 10; D) 55; E) 56.
14. Geometrik progressiyada  $b_1 = 2$ ,  $q = 3$  bo'lsa,  $S_6$  ni toping.  
A) 1458; B) 729; C) 364; D) 728; E) to'g'ri javob berilmagan.
15. Geometrik progressiyada  $q = \frac{1}{3}$ ,  $S = 364$  bo'lsa,  $b_1$  ni toping.  
A)  $63\frac{2}{3}$ ; B) 81; C)  $121\frac{1}{3}$ ; D) 240; E) 243.
16. Geometrik progressiyada  $S_4 = 10\frac{5}{8}$ ,  $S_5 = 42\frac{5}{8}$  bo'lsa,  $q$  ni toping.  
A) 4; B) 2; C) 8; D)  $\frac{1}{2}$ ; E)  $\sqrt{2}$ .

17. Geometrik progressiyada 6 ta had bor. Dastlabki 3 ta hadining yig'indisi 26 ga, keyingi 3 tahadining yig'indisi esa 702 ga teng. Progressiya maxrajini toping.  
A) 4; B) 3; C)  $\frac{1}{3}$ ; D)  $2\sqrt{3}$ ; E)  $\frac{4}{3}$ .
18. Cheksiz kamayuvchi geometrik progressiyada  $b_1 = \frac{1}{4}$ ,  $S = 16$  bo'lsa,  $q$  ni toping.  
A)  $\frac{1}{2}$ ; B)  $\frac{64}{65}$ ; C)  $\frac{63}{64}$ ; D)  $\frac{1}{4}$ ; E)  $\frac{1}{8}$ .
19. Geometrik progressiyada  $q = \frac{\sqrt{3}}{2}$ ,  $b_1 = 2 - \sqrt{3}$  bo'lsa,  $S$  ni toping.  
A)  $2 + \sqrt{3}$ ; B) 3; C)  $\frac{2\sqrt{3}}{3}$ ; D) 2; E)  $\sqrt{3}$ .



### Tarixiy masalalar

- Beruniy masalasi.* Agar hadlari musbat geometrik progressiyaning: hadlari soni toq bo'lsa, u holda  $b_{k+1}^2 = b_1 \cdot b_{2k+1}$ ; hadlari soni juft bo'lsa,  $b_k \cdot b_{k+1} = b_1 \cdot b_{2k}$  bo'lishini isbotlang.
- Axmes papirusidan olingan masala (eramizdan oldingi 2000- yillar).* 10 o'lchov g'allani 10 kishi orasida shunday taqsimlaginki, bu kishilarning biri bilan undan keyingisi (yoki oldingisi) olgan g'alla farqi  $\frac{1}{8}$  o'lchovga teng bo'lsin.



### Tarixiy ma'lumotlar

«Qadimgi xalqlardan qolgan yodgorliklar» asarida Abu Rayhon Beruniy shaxmatning kashf etilishi haqidagi rivoyat bilan bog'liq birinchi hadi  $b_1 = 1$  va maxraji  $q = 2$  bo'lgan geometrik progressiyaning birinchi 64 ta hadining yig'indisini hisoblaydi; shaxmat taxtasidagi  $k$ - katakka mos son dan 1 soni ayirilsa, ayirma  $k$ - katakdan oldingi barcha kataklarga mos sonlar yig'indisiga teng bo'lishini ko'rsatadi, ya'ni

$$q^k - 1 = 1 + q + q^2 + \dots + q^{k-1}$$

ekanini isbotlaydi.

## IX SINFLAR «ALGEBRA» KURSINI TAKRORLASH UCHUN MASHQLAR

491. Funksiyaning grafigini yasang:

1)  $y = x^2 + 6x + 9$ ;      2)  $y = x^2 - \frac{7}{2}$ ;      3)  $y = x^2 - 12x + 4$ ;

4)  $y = x^2 + 3x - 1$ ;      5)  $y = x^2 + x$ ;      6)  $y = x^2 - x$ ;

7)  $y = (x - 2)(x + 5)$ ;      8)  $y = \left(x + \frac{1}{8}\right)(x + 4)$ .

492. (Og'zaki.)  $y = ax^2 + bx + c$  funksiya grafigidan foydalanib (82- rasm), uning koeffitsientlarini aniqlang.

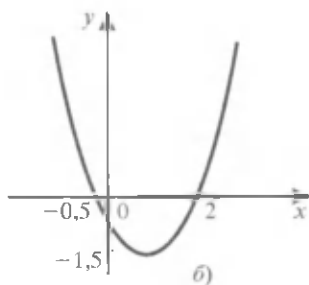
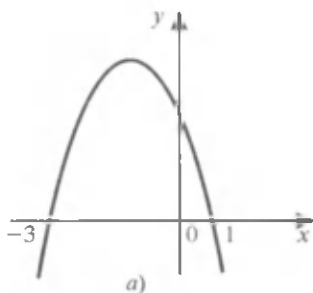

82- rasm.

493. Funksiyaning grafigini yasang va koeffitsientlarini aniqlang:

1)  $y = -2x^2 - 8x - 8$ ;      2)  $y = 3x^2 + 12x + 16$ ;

3)  $y = 2x^2 - 12x + 19$ ;      4)  $y = 3 + 2x - x^2$ ;

5)  $y = -4x^2 - 4x$ ;      6)  $y = 12x - 4x^2 - 9$ .

494. Funksiyaning grafigini bitta koordinata tekisligida yasang:

1)  $y = \frac{1}{3}x^2$  va  $y = -\frac{1}{3}x^2$ ;      2)  $y = 3x^2$  va  $y = 3x^2 - 2$ ;

3)  $y = -\frac{1}{2}x^2$  va  $y = -\frac{1}{2}(x + 3)^2$ ;      4)  $y = 2x^2$  va  $y = 2(x - 5)^2 + 3$ .

Tengsizlikni yeching (495–499):

495. 1)  $(x - 5)(x + 3) > 0$ ;      2)  $(x + 15)(x + 4) < 0$ ;

3)  $(x - 7)(x + 11) \leq 0$ ;      4)  $(x - 12)(x - 13) \geq 0$ .

496. 1)  $x^2 + 3x > 0$ ;                      2)  $x^2 - x\sqrt{5} < 0$ ; ;  
       3)  $x^2 - 16 \leq 0$ ;                      4)  $x^2 - 3 > 0$ .
497. 1)  $x^2 - 8x + 7 > 0$ ;                      2)  $x^2 + 3x - 54 < 0$ ;  
       3)  $\frac{1}{2}x^2 + 0,5x - 1 > 0$ ;                4)  $5x^2 + 9,5x - 1 < 0$ ;  
       5)  $-x^2 - 3x + 4 > 0$ ;                      6)  $-8x^2 + 17x - 2 \leq 0$ .
498. 1)  $x^2 - 6x + 9 > 0$ ;                      2)  $x^2 - 24x + 144 \leq 0$ ;  
       3)  $\frac{1}{2}x^2 - 4x + 8 < 0$ ;                      4)  $\frac{1}{3}x^2 + 4x + 12 \geq 0$ ;  
       5)  $4x^2 - 4x + 1 > 0$ ;                      6)  $5x^2 + 2x + \frac{1}{5} < 0$ .
499. 1)  $x^2 - 10x + 30 > 0$ ;                      2)  $-x^2 + x - 1 < 0$ ;  
       3)  $x^2 + 4x + 5 < 0$ ;                      4)  $2x^2 - 4x + 13 > 0$ ;  
       5)  $4x^2 - 9x + 7 < 0$ ;                      6)  $-11 + 8x - 2x^2 < 0$ .

Tengsizlikni intervallar usuli bilan yeching (500–502):

500. 1)  $(x + 3)(x - 4) > 0$ ;                      2)  $\left(x - \frac{1}{2}\right)(x + 0,7) < 0$ ;  
       3)  $(x - 2,3)(x + 3,7) < 0$ ;                4)  $(x + 2)(x - 1) \leq 0$ ;
501. 1)  $(x + 2)(x - 1) \geq 0$ ;                      2)  $(x + 2)(x - 1)^2 \leq 0$ ;  
       3)  $(x + 2)(x - 1)^2 > 0$ ;                      4)  $(2 - x)(x + 3x)^2 \geq 0$ .
502. 1)  $\frac{3-x}{2+x} \geq 0$ ;                                2)  $\frac{0,5+x}{x-2} \leq 0$ ;  
       3)  $\frac{(x-1)(x+2)}{x} < 0$ ;                                4)  $\frac{2x}{(3+x)(1-x)} < 0$ .

503. Trapetsiyaning yuzi 19,22 sm<sup>2</sup> dan ortiq. Uning o'rta chizig'i balandligidan ikki marta katta. Trapetsiyaning o'rta chizig'ini va balandligini toping.

504. 320 m dan ortiq balandlikda uchib ketayotgan samolyotdan geologlarga yuk tashlab yuborildi. Yuk qancha vaqtda yerga kelib tushadi? Erkin tushish tezlanishi 10 m/s<sup>2</sup> ga teng deb qabul qiling.

505. Parallelogrammning tomoni shu tomonga tushirilgan balandlikdan 2 sm ortiq. Agar parallelogrammning yuzi  $15 \text{ sm}^2$  dan ortiq bo'lsa, shu tomonning uzunligini toping.

506. Tengsizlikni intervallar usuli bilan yeching:

1)  $(x+2)(x+5)(x-1)(x+4) > 0$ ;

2)  $(x+1)(3x^2+2)(x-2)(x+7) < 0$ ;

3)  $\frac{3x-1}{3x+1} + \frac{x-3}{x+3} \geq 2$ ;

4)  $\frac{1-3x}{1+3x} + \frac{1+3x}{3x-1} \geq \frac{12}{1-9x^2}$ .

507. Agar  $x^2 + px + q$  kvadrat uchhad  $x = 0$  bo'lganda  $-14$  ga teng qiymatni,  $x = -2$  bo'lganda esa  $-20$  ga teng qiymatni qabul qilsa, shu kvadrat uchhadning  $p$  va  $q$  koeffitsiyentlarini toping.

508. Agar  $y = x^2 + px + q$  parabola:

1) absissalar o'qini  $x = -\frac{1}{2}$  va  $x = \frac{2}{3}$  nuqtalarda kessa;

2) absissalar o'qi bilan  $x = -7$  nuqtada urinsa;

3) absissalar o'qini  $x = 2$  va ordinatalar o'qini  $y = -1$  nuqtada kesib o'tsa,  $p - q$  ni toping.

509. Agar parabola absissalar o'qini 5 nuqtada kessa va uning uchi

$\left(2\frac{3}{4}; 10\frac{1}{8}\right)$  nuqta bo'lsa, shu parabolaning tenglamasini yozing.

510. Teleskopning (reflektorning) qaytaruvchi ko'zgusi o'q kesimi bo'yicha parabola shakliga ega (83-rasm). Shu parabolaning tenglamasini yozing.

511. Agar  $y = ax^2 + bx + c$  kvadrat funksiyaning grafigi:

1)  $A(-1; 0)$ ,  $B(3; 0)$  va  $C(0; -6)$  nuqtalardan o'tsa;

2)  $K(-2; 0)$ ,  $L(1; 0)$ ,  $M(0; 2)$  nuqtalardan o'tsa, uning koeffitsiyentlarini toping.

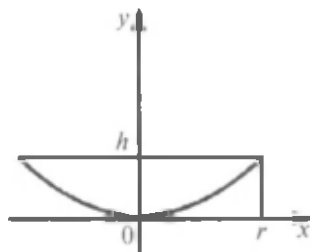

83-rasm.

512. Istalgan nomanfiy  $a$  va  $b$  sonlar uchun

1)  $a^2 + b^2 \leq (a+b)^2$ ;      2)  $a^3 + b^3 \leq (a+b)^3$ ;

3)  $a^3 + b^3 \geq a^2b + ab^2$ ;      4)  $(a+b)^3 \leq 4(a^3 + b^3)$

tengsizlikning to'g'ri bo'lishini isbotlang.

**513.** Istalgan musbat  $a, b, c$  sonlar uchun

$$\begin{array}{ll} 1) \frac{a}{b} + \frac{b}{c} + \frac{c}{a} \geq 3; & 2) \frac{bc}{a} + \frac{ac}{b} + \frac{ab}{c} \geq a + b + c; \\ 3) \frac{a^3 + b^3 + c^3}{a^2 + b^2 + c^2} \geq \frac{a+b+c}{3}; & 4) \frac{a}{b+c} + \frac{b}{c+a} + \frac{c}{a+b} \geq \frac{3}{2} \end{array}$$

tengsizlikning to'g'ri ekanini isbotlang.

**514.** Funksiyaning grafigini yasang:

$$\begin{array}{ll} 1) y = \sqrt{x^2}; & 2) y = |x - 1|; \\ 3) y = \sqrt{x^2 - 6x + 9}; & 4) y = \sqrt{x^2 + 4x + 4}; \\ 5) y = \sqrt{(x-1)^2 + \sqrt{x+1}^2}; & 6) y = \sqrt{x^2 - 4x + 4} + |x + 2|. \end{array}$$

**515.** Tenglamani haqiqiy ildizlarini toping:

$$\begin{array}{lll} 1) x^2 - |x| - 2 = 0; & 2) x^2 - 4|x| + 3 = 0; & 3) |x^2 - x| = 2; \\ 4) |x^2 + x| = 1; & 5) |x^2 - 2| = 2; & 6) |x^2 - 26| = 10. \end{array}$$

**516.** Ildiz chiqaring:

$$1) \sqrt[3]{7\frac{19}{32}}; \quad 2) \sqrt{5\frac{4}{9}}; \quad 3) \sqrt[3]{\frac{8b^6}{343a^9}}, a \neq 0; \quad 4) \sqrt[4]{\frac{16x^8}{81y^4}}, y > 0.$$

**517.** Soddalashtiring:

$$\begin{array}{ll} 1) (3\sqrt{20} + 7\sqrt{15} - \sqrt{5}) : \sqrt{5}; & 2) (\sqrt[3]{7} - \sqrt[3]{14} + \sqrt[3]{56}) : \sqrt[3]{7}; \\ 3) 2\sqrt{\frac{3}{2}} + \sqrt{6} - 3\sqrt{\frac{2}{3}}; & 4) 7\sqrt{1\frac{3}{4}} - \sqrt{7} + 0,5\sqrt{343}. \end{array}$$

**518.** Ifodalarning qiymatlarini taqqoslang:

$$1) \left(\frac{\sqrt{5}}{3}\right)^{-1/3} \text{ va } \left(\frac{\sqrt{5}}{3}\right)^{-1/2}; \quad 2) (2\sqrt{0,5})^{0,3} \text{ va } (2\sqrt{0,5})^{0,37}.$$

**519.** Ifodani soddalashtiring:

$$1) \frac{\sqrt[6]{a^3\sqrt{a^{-1}}}}{a^{-\frac{2}{9}}}; \quad 2) \frac{\sqrt[4]{x^3\sqrt[3]{x}}}{x^{\frac{1}{3}}}; \quad 3) (16a^{-4})^{-\frac{3}{4}}; \quad 4) (27b^{-6})^{\frac{2}{3}}.$$

**520.** Ildiz belgisi ostidan ko'paytuvchini chiqaring:

$$\begin{array}{ll} 1) \sqrt{9a^2b}, \text{ bunda } a < 0, b > 0; & 2) \sqrt{25a^2b^3}, \text{ bunda } a > 0, b > 0; \\ 3) \sqrt{8a^3b^5}, \text{ bunda } a < 0, b < 0; & 4) \sqrt{12a^3b^3}, \text{ bunda } a < 0, b < 0. \end{array}$$

521. Ko'paytuvchini ildiz belgisi ostiga kiriting:

- 1)  $x\sqrt{5}$ , bunda  $x \geq 0$ ;                      2)  $x\sqrt{3}$ , bunda  $x < 0$ ;  
3)  $-a\sqrt{3}$ , bunda  $a \geq 0$ ;                      4)  $-a\sqrt{5}$ , bunda  $a < 0$ .

522. Hisoblang:

- 1)  $\sqrt[3]{1000} \cdot (0,0001)^{0,25} + (0,027)^{\frac{1}{3}} \cdot 7,1^0 - \left(\frac{10}{13}\right)^{-1}$ ;  
2)  $\left(2\frac{10}{27}\right)^{\frac{2}{3}} : \frac{1}{\sqrt{11\frac{1}{9}}} + (6,25)^{\frac{1}{2}} : (-4)^{-1}$ .

523. Ifodaning qiymatini toping:

- 1)  $\left(\frac{a^{\frac{1}{2}}}{a^{\frac{1}{2}} - b^{\frac{1}{2}}} - \frac{a^{\frac{1}{2}}b^{\frac{1}{2}}}{a - b}\right) \cdot \frac{a - 2a^{\frac{1}{2}}b^{\frac{1}{2}} + b}{a}$  bunda  $a = 3, b = 12$ .  
2)  $\frac{m + 2\sqrt{mn} + n}{n} \cdot \frac{\sqrt{mn} + n}{m - n} - \frac{\sqrt{m}}{\sqrt{m} + \sqrt{n}}$ , bunda  $m = 5, n = 20$ .

524. Tenglamani yeching:

- 1)  $x^{\frac{1}{2}} = 2$ ;    2)  $x^{-\frac{1}{2}} = 3$ ;    3)  $x^{-3} = 8$ ;    4)  $x^{\frac{5}{2}} = 0$ .

525.  $y = -\frac{25}{x}$  funksiyaning grafigiga:

- 1)  $A(\sqrt{5}; -5\sqrt{5})$ ;                      2)  $B(-5\sqrt{2}; 5\sqrt{2})$   
nuqta tegishli bo'lish yoki bo'lmasligini aniqlang.

526.  $y = \sqrt{1 - 2x}$  funksiyaning grafigiga: 1)  $C\left(\frac{1}{4}; \frac{\sqrt{2}}{2}\right)$ ; 2)  $D\left(-\frac{1}{2}; 1\right)$

nuqta tegishli bo'lish yoki bo'lmasligini aniqlang.

527. Funksiyaning aniqlanish sohasini toping:

- 1)  $y = \sqrt{-x^2 - 3x + 10}$ ;    2)  $y = \sqrt[4]{\frac{x-7}{3-2x}}$ ;    3)  $y = \sqrt[3]{\frac{x+4}{6-x}}$ ;  
4)  $y = \sqrt[6]{\frac{2x+15}{6}}$ ;    5)  $y = \sqrt[5]{\frac{x}{0,5x+1}}$ ;    6)  $y = \frac{\sqrt{x}}{x^2-4}$ .

528. Funktsiyaning grafigini yasang:

1)  $y = x^2 + 6x + 10$ ;      2)  $y = -x^2 - 7x - 6$ ;      3)  $y = \frac{4}{x}$ ;

4)  $y = -\frac{6}{x}$ ;      5)  $y = \frac{x^2}{2}$ ;      6)  $y = \frac{1}{4}x^4$ .

Qaysi oraliqlarda funktsiyaning o'sichi, kamayishini grafik bo'yi-cha aniqlang; funktsiyaning juft yoki toqligini aniqlang.

529.  $P(1; 0)$  nuqtani: 1)  $A(0; 1)$ ; 2)  $B(0; -1)$ ; 3)  $C(-1; 0)$ ; 4)  $D(1; 0)$  nuqtaga o'tkazadigan bir necha burish burchaklarini ko'rsating.

530. Hisoblang: 
$$\frac{2\sin\frac{\pi}{4} + \cos\frac{\pi}{3} - \operatorname{tg}\frac{\pi}{3}}{\operatorname{ctg}\frac{\pi}{6} - \sin\frac{\pi}{6} - \cos\frac{\pi}{4}}$$

531. Sonning musbat yoki manfiy ekanligini aniqlang:

1)  $\sin\frac{\pi}{5}\sin\frac{4\pi}{5}\cos\frac{\pi}{6}$ ;      2)  $\sin\alpha\cos(\pi + \alpha)\operatorname{tg}\alpha$ ,  $0 < \alpha < \frac{\pi}{2}$ .

532. Berilgan:  $\sin\alpha = 0,6$ ,  $\sin\beta = -0,28$ ,  $0 < \alpha < \frac{\pi}{2}$ ,  $\pi < \beta < \frac{3\pi}{2}$ .

Hisoblang: 1)  $\cos(\alpha - \beta)$ ; 2)  $\sin(\alpha + \beta)$ .

533. Ko'paytuvchilarga ajrating:

1)  $\sin 2\alpha - 2\sin\alpha$ ;      2)  $\sin\alpha + \sin\frac{\alpha}{2}$ ;  
3)  $\cos\alpha - \sin 2\alpha$ ;      4)  $1 - \sin 2\alpha - \cos^2\alpha$ .

534. Agar  $\cos\frac{\alpha}{2} = -\frac{8}{17}$  va  $\sin\frac{\alpha}{2} < 0$  bo'lsa,  $\sin\alpha$ ,  $\cos\alpha$ ,  $\operatorname{tg}\alpha$  ni hisoblang.

535. Agar

1)  $a_1 = 10$ ,  $d = 6$ ,  $n = 23$ ;      2)  $a_1 = 42$ ,  $d = \frac{1}{2}$ ,  $n = 12$ ;

3)  $a_1 = 0$ ,  $d = -2$ ,  $n = 7$ ;      4)  $a_1 = \frac{1}{3}$ ,  $d = \frac{2}{3}$ ,  $n = 18$

bo'lsa, arifmetik progressiyaning  $n$ -hadini va dastlabki  $n$  ta hadining yig'indisini hisoblang.

536. Agar  $a_1 = 2$ ,  $a_n = 120$ ,  $n = 20$  bo'lsa, arifmetik progressiyaning dastlabki  $n$  ta hadi yig'indisini toping.



537.  $n$ -hadi  $a_n = \frac{1-2n}{3}$  formula bilan berilgan ketma-ketlik arifmetik progressiya bo'lishini isbotlang.

538. Agar geometrik progressiya uchun

1)  $b_1 = 5$  va  $q = -10$  bo'lsa,  $b_4$  ni toping;

2)  $b_4 = -5000$  va  $q = -10$  bo'lsa,  $b_1$  ni toping.

539. Agar:

1)  $b_1 = 3, q = 2, n = 5;$       2)  $b_1 = 1, q = 5, n = 4;$

3)  $b_1 = 8, q = \frac{1}{4}, n = 4;$       4)  $b_1 = 1, q = -3, n = 5$

bo'lsa, geometrik progressiyaning  $n$ -hadini va dastlabki  $n$  ta hadi yig'indisini hisoblang.

540. Agar  $b_1 = \frac{1}{4}, q = 2, n = 6$  bo'lsa, geometrik progressiya dastlabki  $n$  ta hadining yig'indisini toping.

541. Cheksiz kamayuvchi geometrik progressiya yig'indisini toping.

1)  $6, 4, \frac{8}{3}, \dots;$       2)  $5, -1, \frac{1}{5}, \dots;$       3)  $1, -\frac{1}{4}, \frac{1}{16}, \dots,$

4)  $\frac{1}{2}, \frac{1}{4}, \frac{1}{8}, \dots$       5)  $\sqrt{2}, 1, \frac{\sqrt{2}}{2}, \dots;$       6)  $-\sqrt{5}, -1, -\frac{\sqrt{5}}{5}, \dots$

542. Ildiz belgisi ostidan ko'paytuvchini chiqaring:

1)  $\sqrt{20a^4b}$ , bunda  $a < 0, b > 0$ .

2)  $\sqrt[3]{8a^3b^4}$ , bunda  $a < 0, b > 0$ .

3)  $\sqrt{(a-1)^2}$ , bunda  $a < 1$ ;

4)  $\sqrt{(3+a)^2}$ , bunda  $a > -3$ .

543. Ifodani soddalashtiring:

1)  $\frac{\sqrt{(a-b)^2}}{a-b}$ , bunda  $a > b$ ;

2)  $\frac{\sqrt{(a-b)^2}}{a-b}$ , bunda  $b > a$ ;

3)  $\frac{\sqrt{1+\frac{1}{x}+\frac{1}{x^2}}}{\sqrt{x^2+x+1}}$ , bunda  $x > 0$ ;

4)  $\frac{\sqrt{1+\frac{1}{x}+\frac{1}{x^2}}}{\sqrt{x^2+x+1}}$ , bunda  $x < 0$ .

544. Tengliklardan qaysinisi to'g'ri:

$$\sqrt{7-4\sqrt{3}} = 2-\sqrt{3} \text{ mi yoki } \sqrt{7-4\sqrt{3}} = \sqrt{3}-2 \text{ mi?}$$

545. Maxrajdagi irratsionallikni yo'qoting:

$$1) \frac{1}{2+\sqrt[3]{3}}; \quad 2) \frac{1}{\sqrt{a-\sqrt[3]{b}}}; \quad 3) \frac{1}{\sqrt[3]{3-\sqrt[3]{2}}}; \quad 4) \frac{2}{\sqrt{5+\sqrt{5}}}.$$

546. Ifodani soddalashtiring:

$$1) \frac{\sqrt{ab}\sqrt[4]{a}}{(a+2)\sqrt[4]{a^{-1}b^2}} - \frac{a^2+4}{a^2-4}; \quad 2) \left( \frac{\sqrt{a}}{b+\sqrt{ab}} - \frac{\sqrt{a}}{b-\sqrt{ab}} \right) \cdot \frac{b-a}{2\sqrt{ab}};$$

$$3) \left( \frac{a-b}{a^{\frac{3}{4}}+a^{\frac{1}{4}}b^{\frac{3}{4}}} - \frac{a^{\frac{1}{4}}-b^{\frac{1}{4}}}{a^{\frac{3}{4}}+a^{\frac{1}{4}}} \right) \cdot \frac{a^{\frac{1}{4}}+b^{\frac{1}{4}}}{(a^{-1}b)^{\frac{1}{2}}}; \quad 4) \left( \frac{a^{\frac{3}{2}}+b^{\frac{3}{2}}}{a-b} - \frac{a-b}{a^{\frac{1}{2}}+b^{\frac{1}{2}}} \right) \cdot \frac{a-b}{\sqrt{ab}}.$$

547.  $y = \frac{4}{x^2}$  funksiyaning  $x > 0$  oraliqda o'sishi yoki kamayishini aniqlang.

548. Funksiyaning aniqlanish sohasini toping.

$$1) y = \sqrt{(x-2)(x-3)}; \quad 2) y = \sqrt{x^2-6x}; \quad 3) y = \frac{1}{x^2-2\sqrt{2x+2}};$$

$$4) y = \frac{3}{2\sqrt{3x-x^2+3}}; \quad 5) y = \sqrt{\frac{(x-1)x}{x+5}}; \quad 6) y = \sqrt{\frac{x^2-9}{x^2-2x}}.$$

549. Funksiyaning grafigini yasang va grafik bo'yicha uning asosiy xossalarni aniqlang:

$$1) y = \frac{3}{x+1}; \quad 2) y = \frac{1}{2-x}; \quad 3) y = \frac{x+2}{x};$$

$$4) y = \frac{3-x}{x}; \quad 5) y = \sqrt{x-3}; \quad 6) y = \sqrt[3]{2-x}.$$

550. Tenglamani yeching:

$$1) \sqrt{x-2} = 4; \quad 2) \sqrt{x+3} = 8; \quad 3) \sqrt{2x+1} = \sqrt{x-1};$$

$$4) \sqrt{3-x} = \sqrt{1+3x}; \quad 5) \sqrt[4]{x^2+12} = x; \quad 6) \sqrt[3]{6x-x^2} = x.$$

551. Ifodani soddalashtiring:

$$1) \frac{\operatorname{tg}^2 \alpha}{1+\operatorname{ctg}^2 \alpha}; \quad 2) \frac{1+\operatorname{ctg}^2 \alpha}{\operatorname{ctg}^2 \alpha};$$

$$3) \frac{\operatorname{tg} \alpha - \operatorname{tg} \beta}{\operatorname{ctg} \alpha + \operatorname{ctg} \beta}; \quad 4) (\operatorname{tg} \alpha + \operatorname{ctg} \alpha)^2 - (\operatorname{tg} \alpha - \operatorname{ctg} \alpha)^2.$$

552. Ifodani soddalashtiring:

$$1) \frac{\operatorname{ctg}\left(\alpha - \frac{\pi}{4}\right) : \left(\sin\left(\alpha - \frac{3}{2}\pi\right) - \sin(\pi + \alpha)\right)}{\operatorname{tg}(\pi + \alpha)(\cos(\alpha + 2\pi) + \sin(\alpha - 2\pi))};$$

$$2) \sin(x - 2\pi)\cos\left(\frac{3\pi}{2} - x\right) + \operatorname{tg}(\pi - x)\operatorname{tg}\left(\frac{3}{2}\pi + x\right).$$

553. Tenglamani yeching:

$$1) 1 - \cos x - 2\sin\frac{x}{2} = 0; \quad 2) 1 + \cos 2x + 2\cos x = 0.$$

554. Ayniyatni isbotlang:

$$1) \frac{\operatorname{tg}(\alpha - \beta) + \operatorname{tg}\beta}{\operatorname{tg}(\alpha + \beta) - \operatorname{tg}\beta} = \frac{\cos(\alpha + \beta)}{\cos(\alpha - \beta)}; \quad 2) \frac{\sin(\alpha + \beta) + \sin(\alpha - \beta)}{\cos(\alpha + \beta) + \cos(\alpha - \beta)} = \operatorname{tg}\alpha.$$

555. Ayniyatni isbotlang:

$$1) 1 + \sin\alpha = 2\cos^2\left(\frac{\pi}{4} - \frac{\alpha}{2}\right); \quad 2) 1 - \sin\alpha = 2\sin^2\left(\frac{\pi}{4} - \frac{\alpha}{2}\right).$$

556. Uchburchakning ichki burchaklari ayirmasi  $\frac{\pi}{6}$  ga teng bo'lgan arifmetik progressiyaning ketma-ket uchta hadi bo'ladi. Shu burchaklarni toping.

557. Arifmetik progressiyada  $a_1 + a_5 = \frac{5}{3}$ ;  $a_3 a_4 = \frac{65}{72}$ . Progressiyaning dastlabki o'n yettita hadining yig'indisini toping.

558. Ikkinchi hadi birinchisidan 35 ga kam, uchinchi hadi esa to'rtinchisidan 560 ga ortiq bo'lgan geometrik progressiyaning dastlabki to'rtta hadini toping.

559. Geometrik progressiyada  $q = 3$ ,  $S_6 = 1820$  bo'lsa,  $b_1$  va  $b_5$  ni toping.

560. Cheksiz kamayuvchi geometrik progressiyaning yig'indisi  $\frac{8}{5}$  ga teng, ikkinchi hadi  $-\frac{1}{2}$  ga teng. Uchinchi hadini toping.

561. Arifmetik progressiyaning ketma-ket hadi bo'lgan uchta sonning yig'indisi 39 ga teng. Agar birinchi sondan 4 ni, ikkinchisidan 5 ni, uchinchisidan esa 2 ni ayirilsa, hosil bo'lgan sonlar geometrik progressiyaning ketma-ket uchta hadi bo'ladi. Shu sonlarni toping.

Ifodani soddalashtiring (562—563):

562. 1)  $\sqrt{5 + \sqrt{21}}$ ;      2)  $\sqrt{4 + \sqrt{7}}$ .

563. 1)  $\frac{1}{\sqrt{5}} \left[ 4(a+1) + (\sqrt[3]{a\sqrt{a}} - 1)^2 - \left( \frac{\sqrt[5]{ab^2 + \sqrt{a}}}{\sqrt[3]{a + \sqrt[3]{b}}} + \sqrt[3]{a} \right)^3 \right]^{\frac{1}{2}}$ , bunda  $0 < a \leq 1$ ;

2)  $\frac{a^{-1}b^{-2} - a^{-2}b^{-1}}{a^{\frac{5}{3}}b^{-2} - b^{\frac{5}{3}}a^{-2}} - a^{\frac{1}{3}}b^{\frac{1}{3}}$ .

564. Funksiyaning grafigini yasang:

1)  $y = \frac{1}{|x-1|}$ ;    2)  $y = \frac{3}{|x|} - 1$ ;    3)  $y = \sqrt[3]{|x|}$ ;    4)  $y = x^2 - 3|x| - 4$ .

565. Agar  $\operatorname{tg} \frac{\alpha}{2} = -2,4$  bo'lsa,  $\sin \alpha$  va  $\cos \alpha$  ni hisoblang.

566. Ayniyatni isbotlang:

1)  $\cos\left(\alpha - \frac{2\pi}{3}\right) = -\cos\left(\frac{\pi}{3} + \alpha\right)$ ;    2)  $\cos\left(\alpha - \frac{2\pi}{3}\right) = -\cos\left(\alpha + \frac{4\pi}{3}\right)$ .

567. Quyidagi uchta xossaga ega bo'lgan to'rtta son toping;

a) birinchi va to'rtinchi sonlarning yig'indisi 11 ga teng, ikkinchi va uchinchi sonlarning yig'indisi esa 2 ga teng;

b) birinchi, ikkinchi va uchinchi sonlar arifmetik progressiyaning ketma-ket hadlari bo'ladi;

d) ikkinchi, uchinchi va to'rtinchi sonlar geometrik progressiyaning ketma-ket hadlari bo'ladi.

568.  $S_n$  arifmetik progressiyaning dastlabki  $n$  ta hadi yig'indisi bo'lsin. Isbotlang:

1)  $S_{n+3} = 3S_{n+2} - 3S_{n+1} + S_n$ ;      2)  $S_{3n} = 3(S_{2n} - S_n)$ .

## VII—IX SINFLAR «ALGEBRA» KURSINI TAKRORLASH UCHUN MASHQLAR

### 1. Sonlar va algebraik almashtirishlar

Hisoblang (569—570):

569. 1)  $(5,4 \cdot 1,2 - 3,7 : 0,8) (3,14 + 0,86) : 0,25;$

2)  $(20,88 : 18 + 45 : 0,36) : (19,59 + 11,95);$

3)  $\left(5\frac{8}{9} - 3\frac{11}{12}\right) \cdot \frac{18}{71} - 7\frac{5}{6} : 15\frac{2}{3};$  4)  $\frac{7}{36} \cdot 9 + 8 \cdot \frac{11}{32} + \frac{9}{10} \cdot \frac{5}{18}.$

570. 1)  $\left(3\frac{4}{25} + 20,24\right) \cdot 2,15 + \left(5,1625 - 2\frac{3}{16}\right) \cdot \frac{2}{5};$

2)  $0,364 : \frac{7}{25} + \frac{5}{16} : 0,125 + 2,5 \cdot 0,8;$

3)  $\frac{\left(3,25 - \frac{3}{4}\right) 6,25}{(2 - 0,75) : \frac{4}{5}} + \frac{\left(5,5 - 3\frac{3}{4}\right) : 5}{(-2 - 0,8) \cdot 1\frac{3}{4}};$  4)  $\frac{\left(2\frac{3}{20} + 1\frac{5}{16}\right) : 27,7}{\left(1,75 \cdot \frac{2}{3} - 1,75 \cdot 1\frac{1}{8}\right) : \frac{7}{12}}.$

571. Proporsiyaning noma'lum hadini toping:

1)  $x : 7 = 9 : 3;$  2)  $125 : 25 = 35 : x;$  3)  $144 : x = 36 : 3;$

4)  $9\frac{1}{2} : 14\frac{1}{4} = x : 0,75;$  5)  $\frac{x}{6\frac{5}{6}} = \frac{3,9}{4,1};$  6)  $0,3 : x = \frac{4}{9} : 3\frac{1}{3}.$

572. Agar:

1)  $a = 400, p = 27;$  2)  $a = 2,5, p = 120;$

3)  $a = 2500, p = 0,2;$  4)  $a = 4,5, p = 2,5$

bo'lsa,  $a$  sonning  $p$  protsentini toping.

573. Agar sonning  $p$  protsenti  $b$  ga teng bo'lsa, shu sonning o'zini toping:

1)  $p = 23, b = 690;$  2)  $p = 3,2, b = 9,6;$

3)  $p = 125, b = 3,75;$  4)  $p = 0,6, b = 21,6.$

574.  $a$  son  $b$  sonning qanday protsentini tashkil qiladi:

1)  $a = 24, b = 120;$  2)  $a = 4,5, b = 90;$

3)  $a = 650, b = 13;$  4)  $a = 0,08, p = 0,48 ?$

575. Amallarni bajaring:

1)  $(-3a^3b)(-2ab^2)(-5a^3b^7)$ ;      2)  $35a^5b^4c : (7ab^3c)$ ;

3)  $(-5ab^4c)^3 \cdot \left(-\frac{1}{5}a^5bc^2\right)^2$ ;      4)  $\left(-\frac{2}{3}a^4b^3c^2\right)^3 : \left(-\frac{1}{3}a^2bc^3\right)^2$ .

576. Ifodani standart shakldagi ko'phad ko'rinishida yozing:

1)  $(x - 6)(5 + x) - x^2(x^2 - 5x + 1)$ ;

2)  $(x + 7)(5 - x) - x^2(x^2 + 2x - 1)$ ;

3)  $(b - 3a)^2 + 8\left(a - \frac{1}{2}b\right)\left(a + \frac{1}{2}b\right)$ ;

4)  $(3a + 6)^2 + 4\left(b - \frac{1}{2}a\right)\left(b + \frac{1}{2}a\right)$ .

577. Ifodaning son qiymatini toping:

1)  $a^3 - ba^2$ , bunda  $a = -0,6$ ,  $b = 9,4$ ;

2)  $ab^2 + b^3$ , bunda  $a = 10,7$ ,  $b = -0,7$ ;

3)  $(m - 5)(2m - 3) - 2m(m - 4)$ , bunda  $m = \frac{3}{5}$ ;

4)  $(3a - 2)(a - 4) - 3a(a - 2)$ , bunda  $a = \frac{3}{4}$ .

578. Amallarni bajaring:

1)  $(-15x^5 + 10x^4 - 25x^3) : (-5x^5) - 3(x - 3)(x^2 + 3x + 9)$ ;

2)  $(9a^2b^3 - 12a^4b^4) : 3a^2b - b^2 \cdot (2 + 3a^2b)$ .

Ko'paytuvchilarga ajrating (579–583):

579. 1)  $1 - \frac{a^2}{4}$ ;      2)  $\frac{b^2}{9} - 1$ ;      3)  $a^2 - b^4$ ;      4)  $b^4 - 9$ .

580. 1)  $1 - a + \frac{a^2}{4}$ ;      2)  $0,25b^2 + b + 1$ ;

3)  $49a^2 - 14a + 1$ ;      4)  $1 + 18b + 81b^2$ .

581. 1)  $y^2 - xy - y + x$ ;      2)  $a^2 - ax - x + a$ ;

3)  $3a^2 + 3ab + a + b$ ;      4)  $5a^2 - 5ax - 7a + 7x$ .

582. 1)  $6m^4n + 12m^3n + 3m^2n$ ;      2)  $2a^5b - 4a^4b + 2a^3b$ ;

3)  $a^2 - 2ab + b^2 - y^2$ ;      4)  $a^4 + 2a^2b^2 + b^4 - 4a^2b^2$ .

583. 1)  $x^2 + 3x - 28$ ; 2)  $2x^2 - 12x + 18$ ;  
 3)  $2x^2 - 5x + 3$ ; 4)  $x^2 + x - 2$ .

584. Kasrni qisqartiring:

1)  $\frac{4-b^2}{4b+2b^2}$ ; 2)  $\frac{b^2-9}{3b^2-9b}$ ; 3)  $\frac{5a^2-10ab}{ab-2b^2}$ ; 4)  $\frac{3xy-21y^2}{4x^2-28xy}$ ;  
 5)  $\frac{x^2-x-12}{x^2-16}$ ; 6)  $\frac{x^2-x-20}{x^2-25}$ ; 7)  $\frac{3x^2-2x-8}{2x^2-3x-2}$ ; 8)  $\frac{2x^2+x-3}{2x^2+7x+6}$ .

Ifodani soddalashtiring (585–589):

585. 1)  $\frac{a^5}{6c^3} : \frac{a^2}{4c^3}$ ; 2)  $\frac{9a^2}{m^3} : \frac{6a^2}{m^5}$ ; 3)  $\left(\frac{4a}{b^3}\right) \cdot \frac{b^4}{8a}$ ;  
 4)  $\left(\frac{3c}{k^2}\right) : \frac{9c}{k^3}$ ; 5)  $\frac{5a}{28b^2} \cdot 8ab \cdot \frac{7b}{5a^3}$ ; 6)  $\left(\frac{25a^4b^3}{14c^2}\right) \cdot \frac{-21c}{10a^3b^3}$ ;  
 7)  $\frac{4x(x-1)+1}{4-x^2} : \frac{1-2x}{x-2}$ ; 8)  $\frac{x^2-4(x-1)}{x-1} : \frac{2-x}{1-x^2}$ .

586. 1)  $\frac{a-3}{a+3} - \frac{a^2+27}{a^2-9}$ ; 2)  $\frac{a^2+12}{a^2-4} - \frac{a+3}{a-2}$ ;  
 3)  $\frac{a+1}{a^2-ax} - \frac{x+1}{a^2-x^2}$ ; 4)  $\frac{3-a}{ab-a^2} - \frac{3-b}{b^2-a^2}$ .

587. 1)  $\frac{4}{a-b} + \frac{9}{a+b} - \frac{8a}{a^2-b^2}$ ; 2)  $\frac{42}{4a^2-9} + \frac{8}{2a+3} + \frac{7}{3-2a}$ ;  
 3)  $\left(\frac{a}{b} + \frac{b}{a} - 2\right)ab$ ; 4)  $\left(\frac{1}{a} + \frac{1}{b} - \frac{1}{ab}\right)ab$ .

588. 1)  $\frac{1}{(x+3)^2} : \frac{x}{x^2-9} - \frac{x-9}{x^2-9}$ ; 2)  $\frac{a+6}{a^2-4} - \frac{1}{a^2-4} \cdot \frac{(a+2)^2}{a}$ ;  
 3)  $a + b - \frac{a^2}{a-1}$ ; 4)  $\frac{a^2}{a+1} - a + 1$ .

589. 1)  $\frac{b^2}{a^2-2ab} : \left(\frac{2ab}{a^2-4b^2} - \frac{b}{a+2b}\right)$ ; 2)  $\left(\frac{2xy}{x^2-9y^2} - \frac{y}{x-3y}\right) : \frac{y^2}{x^2+3xy}$ ;  
 3)  $\left(\frac{xy}{x^2-y^2} - \frac{y}{2x-2y}\right) : \frac{3y}{x^2-y^2}$ ; 4)  $\left(\frac{2a+1}{2a-1} - \frac{2a-1}{2a+1}\right) \cdot \frac{10a-5}{4a}$ .

590. Ifodani soddalashtiring va uning son qiymatini toping:

1)  $\frac{a+1}{a-1} + \frac{6}{a^2-1} - \frac{a+3}{a+1}$ , bunda  $a = -9$ ;

2)  $\frac{b+5}{b+2} - \frac{3}{b^2-4} - \frac{b+1}{b-2}$ , bunda  $b = -8$ ;

3)  $\frac{a-2}{a-3} : \left( \frac{a^2-6a+10}{a^2-9} + \frac{2}{a+3} \right)$ , bunda  $a = -1\frac{1}{2}$ ;

4)  $\frac{b+1}{b-4} : \left( \frac{b^2+9}{b^2-16} + \frac{2}{b+4} \right)$ , bunda  $b = 4\frac{1}{3}$ .

591. Hisoblang:

1)  $\left(\frac{1}{2}\right)^{-1} - 3^{-2} : 3^{-5}$ ;

2)  $(-6)^0 \cdot 81^{-2} \cdot 27^3$ .

592. Kasrni qisqartiring:

1)  $\frac{a+\sqrt{3}}{a^2-3}$ ;

2)  $\frac{x-\sqrt{2}}{x^2-2}$ ;

3)  $\frac{y-9y^{\frac{1}{2}}}{\frac{1}{y^4}+3}$ ;

4)  $\frac{x+x^{\frac{1}{2}}}{x-1}$ .

593. Hisoblang:

1)  $(6-3\sqrt{5})(6+3\sqrt{5})$ ;

2)  $(\sqrt{5}-1)(\sqrt{5}+1)$ ;

3)  $(3\sqrt{5}-2\sqrt{20})\sqrt{5}$ ;

4)  $(1-\sqrt{3})^2 + (1+\sqrt{3})^2$ .

594. Hisoblang:

1)  $4\sqrt{3} - \sqrt{3}(\sqrt{16} - \sqrt{3})$ ;

2)  $6\sqrt{2} - \sqrt{2}(\sqrt{2} + \sqrt{36})$ ;

3)  $\sqrt{48} - \sqrt{27} - \frac{1}{2}\sqrt{12}$ ;

4)  $\sqrt{50} - \sqrt{32} - \frac{1}{3}\sqrt{18}$ ;

5)  $(\sqrt{2}+3)^2 - 3\sqrt{8}$ ;

6)  $(2-\sqrt{3})^2 + 2\sqrt{12}$ .

595. Hisoblang:

1)  $(\sqrt{4+\sqrt{7}} + \sqrt{4-\sqrt{7}})^2$ ;

2)  $(\sqrt{3-\sqrt{5}} - \sqrt{3+\sqrt{5}})^2$ ;

3)  $\frac{1}{5-\sqrt{5}} - \frac{1}{5+\sqrt{5}}$ ;

4)  $\frac{1}{7+4\sqrt{3}} + \frac{1}{7-4\sqrt{3}}$ .



596. Soddashtiring:

$$1) \frac{1}{3-\sqrt{2}} + \frac{1}{3+\sqrt{2}};$$

$$2) \frac{1}{5-\sqrt{3}} - \frac{1}{5+\sqrt{3}};$$

$$3) \frac{3-\sqrt{2}}{3+\sqrt{2}} + \frac{3+\sqrt{2}}{3-\sqrt{2}};$$

$$4) \frac{3}{\sqrt{3}-\sqrt{2}} - \frac{3}{\sqrt{3}+\sqrt{2}}.$$

597. Sonni standart shaklda yozing:

$$1) 0,00051; \quad 2) \frac{1}{500}; \quad 3) 250000; \quad 4) \frac{3}{2500}.$$

$$598. \text{ Hisoblang: } 1) \frac{(0,25)^5 \cdot 8^6}{2^6 \cdot \left(\frac{1}{2}\right)^3}; \quad 2) \frac{16 \cdot 4^{-2} + 4 \left(\frac{2}{3}\right)^{-2}}{4 + \left(\frac{1}{16}\right)^{-\frac{1}{2}}}.$$

$$599. \text{ Hisoblang: } 1) \sqrt{8,75^3 + 8,75^2 \cdot 7,25}; \quad 2) \frac{0,625 \cdot 6,75^2 - 3,25^2 \cdot 0,625}{\sqrt{3,5^2 + 7 \cdot 2,75 + 2,75^2}}.$$

600.  $x > 0, y > 0$  bo'lganda soddashtiring:

$$1) \sqrt{\frac{4}{81} x^6 y^{20}}; \quad 2) \sqrt{x^4 y^{18}}; \quad 3) \sqrt[3]{27 x^3 y^6}; \quad 4) \sqrt[5]{x^5 y^{10}}.$$

601. Ifodani soddashtiring:

$$1) \left( \frac{\frac{1}{a^2} - \frac{1}{b^2}}{\frac{1}{a^2} + \frac{1}{b^2}} + \frac{2a^{\frac{1}{2}} b^{\frac{1}{2}}}{a-b} \right) \cdot \frac{a-2a^{\frac{1}{2}} b^{\frac{1}{2}} + b}{a+b};$$

$$2) \left( \frac{1}{\frac{1}{a^2} + a} - \frac{a^{\frac{1}{2}}}{a^2 + 1} \right) \cdot \frac{a^{\frac{1}{2}}}{a^2 - 1};$$

$$3) \frac{x^{\frac{1}{2}}}{1+x^{\frac{1}{2}}} \cdot \left( \frac{\frac{1}{x^{\frac{1}{2}}}}{1-x^{\frac{1}{2}}} - \frac{1}{x^{\frac{1}{2}} - x} \right);$$

$$4) \frac{m+2m^{\frac{1}{2}}+1}{2m^{\frac{1}{2}}} \cdot \left( \frac{\frac{1}{2m^2}}{m^2-1} - \frac{4m^{\frac{1}{2}}}{m-1} \right).$$

## 2. Tenglamalar

Tenglamani yeching (602–605):

$$602. 1) 8(3x - 7) - 3(8 - x) = 5(2x + 1);$$

$$2) 10(2x - 1) - 9(x - 2) + 4(5x + 8) = 71;$$

$$3) 3 + x(5 - x) = (2 - x)(x + 3);$$

$$4) 7 - x(3 + x) = (x + 2)(5 - x).$$

$$603. 1) \frac{5x-7}{6} - \frac{x+2}{7} = 2;$$

$$2) \frac{4x-8}{3} - \frac{3+2x}{5} = 8;$$

$$3) \frac{14-x}{4} + \frac{3x+1}{5} = 3;$$

$$4) \frac{2x-5}{4} - \frac{6x+1}{8} = 2.$$

$$604. 1) \frac{4}{3(x+2)} = \frac{9}{8x+11};$$

$$2) \frac{1}{3(x-1)} = \frac{3}{2(x+6)};$$

$$3) \frac{x}{5-x} + \frac{5-x}{5+x} = -2;$$

$$4) \frac{x+3}{x-3} + \frac{x}{x+3} = 2.$$

$$605. 1) x(x-1) = 0;$$

$$2) (x+2)(x-3) = 0;$$

$$3) x\left(2x - \frac{1}{2}\right)(4+3x) = 0;$$

$$4) \frac{(x-5)(x+1)}{x^2+1} = 0.$$

Tenglamani yeching (606–608):

$$606. 1) x^2 + 3x = 0; \quad 2) 5x - x^2 = 0; \quad 3) 4x + 5x^2 = 0;$$

$$4) -6x^2 - x = 0; \quad 5) 2x^2 - 32 = 0; \quad 6) 2 - \frac{x^2}{2} = 0;$$

$$7) \left(\frac{x}{2}\right)^2 - 1 = 0; \quad 8) x^2 - 8 = 0.$$

$$607. 1) 2x^2 + x - 10 = 0; \quad 2) 2x^2 - x - 3 = 0;$$

$$608. 1) 7x^2 - 13x - 2 = 0; \quad 2) 4x^2 - 17x - 15 = 0.$$

Tenglamani yeching (609–614):

$$609. 1) (3x+4)^2 + 3(x-2) = 46; \quad 2) 2(1-1,5x) + 2(x-2)^2 = 1;$$

$$3) (5x-3)(x+2) - (x+4)^2 = 0; \quad 4) x(11-6x) - 20 + (2x-5)^2 = 0.$$

$$610. 1) |x| = \frac{1}{2}; \quad 2) |x-1| = 4; \quad 3) |3-x| = 2;$$

$$4) |3x| - 3x = 6; \quad 5) |2,5-x| + 3 = 5; \quad 6) |3,7+x| - 2 = 6;$$

$$611. 1) \frac{7}{2x+9} - 6 = 5x;$$

$$2) \frac{x^2}{x-2} - \frac{x+2}{x-2} = 4;$$

$$3) \frac{x}{x^2-16} + \frac{x-1}{x+4} = 1;$$

$$4) \frac{12}{(x+6)^2} + \frac{x}{x+6} = 1.$$

$$612. 1) x^4 - 17x^2 + 16 = 0;$$

$$2) x^4 - 37x^2 + 36 = 0;$$

$$3) 2x^4 - 5x^2 - 12 = 0;$$

$$4) x^4 - 3x^2 - 4 = 0.$$

613. 1)  $\sqrt{x+1} - 5 = 0$ ;    2)  $6 - \sqrt{x+3} = 0$ ;    3)  $\sqrt{5-x} - 1 = x$ ;  
 4)  $3 + \sqrt{x-5} = x - 4$ ; 5)  $7x - \sqrt{2x+2} = 5x$ ; 6)  $12x - \sqrt{5x-4} = 11x$ .
614. 1)  $2^{x-1} = 64$ ;    2)  $3^{1-x} = 27$ ;    3)  $3^{x-8} = 27$ ;    4)  $7^{2x-1} = 49$ .

615. Tenglamani grafik usulda yeching:

- 1)  $x^3 = 3x + 2$ ;    2)  $x^3 = -x - 2$ ;    3)  $\frac{5}{x} = 6 - x$ ;  
 4)  $x^{-1} = 2x - 1$ ;    5)  $\sqrt{x} = \frac{x+3}{4}$ ;    6)  $\sqrt{x} = 6 - x$ .

Tenglamalar sistemasini yeching (616–618):

616. 1)  $\begin{cases} x + y = 12, \\ x - y = 2; \end{cases}$     2)  $\begin{cases} x + y = 10, \\ y - x = 4; \end{cases}$     3)  $\begin{cases} 2x + 3y = 11, \\ 2x - y = 7; \end{cases}$   
 4)  $\begin{cases} 3x + 5y = 21, \\ 6x + 5y = 27; \end{cases}$     5)  $\begin{cases} 3x + 5y = 4, \\ 2x - y = 7; \end{cases}$     6)  $\begin{cases} 4x - 3y = 1, \\ 3x + y = -9. \end{cases}$

617. 1)  $\begin{cases} \frac{2x}{3} = \frac{3y}{4} - 2, \\ \frac{1}{2}x + \frac{1}{4}y = 5; \end{cases}$     2)  $\begin{cases} \frac{3}{7}x - \frac{2}{5}y = 2, \\ \frac{3}{4}x + \frac{1}{6}y = 12\frac{1}{6}; \end{cases}$   
 3)  $\begin{cases} \frac{1}{2}(x+11) = \frac{1}{3}(y+13) + 2, \\ 5x = 3y + 8; \end{cases}$     4)  $\begin{cases} \frac{1}{4}(x+3y) = \frac{1}{3}(x+2y), \\ x + 5y = 12. \end{cases}$

618. 1)  $\begin{cases} x - y = 7, \\ xy = 18; \end{cases}$     2)  $\begin{cases} x - y = 2, \\ xy = 15; \end{cases}$     3)  $\begin{cases} x + y = 2, \\ xy = -15; \end{cases}$   
 4)  $\begin{cases} x + y = -5, \\ xy = -36; \end{cases}$     5)  $\begin{cases} x^2 + y^2 = 13, \\ xy = 6; \end{cases}$     6)  $\begin{cases} x^2 + y^2 = 41, \\ xy = 20. \end{cases}$

### 3. Tengsizliklar

Tengsizlikni yeching (619–620):

619. 1)  $3x - 7 < 4(x + 2)$ ;    2)  $7 - 6x \geq \frac{1}{3}(9x - 1)$ ;  
 3)  $1,5(x - 4) + 2,5x < x + 6$ ;    4)  $1,4(x + 5) + 1,6x > 9 + x$ .

620. 1)  $\frac{x-1}{3} - \frac{x-4}{2} \leq 1$ ;      2)  $\frac{x+4}{5} - \frac{x-1}{4} \geq 1$ ;      3)  $\frac{x-1}{2} + \frac{x+1}{3} \geq 7$ ;  
 4)  $\frac{2x-5}{4} - \frac{3-2x}{5} < 1$ ;      5)  $x + \frac{x-3}{6} > 3$ ;      6)  $x + \frac{x+2}{4} < 3$ .

621. Tengsizliklar sistemasini yeching:

1)  $\begin{cases} x + 5 \geq 5x - 3, \\ 2x - 5 < 0; \end{cases}$       2)  $\begin{cases} 2x + 3 \geq 0, \\ x - 7 < 4x - 1; \end{cases}$   
 3)  $\begin{cases} 5x - 1 \leq 7 + x, \\ -0,2x > 1; \end{cases}$       4)  $\begin{cases} 3x - 2 \geq 10 - x, \\ -0,5x < 1. \end{cases}$

622. Tengsizlikning natural sonlardan iborat barcha yechimlarini toping:

1)  $\frac{x-2}{6} - x \geq \frac{x-8}{3}$ ;      2)  $\frac{x+5}{2} > \frac{x-5}{4} + x$ .

623. Tengsizliklar sistemasining butun sondan iborat barcha yechimlarini toping:

1)  $\begin{cases} 2(x+1) < 8-x, \\ -5x-9 < 6; \end{cases}$       2)  $\begin{cases} 3(x-1) > x-7, \\ -4x+7 > -5; \end{cases}$   
 3)  $\begin{cases} 3y + \frac{2y-13}{11} > 2, \\ \frac{y}{6} - \frac{3y-20}{9} < -\frac{2}{3}(y-7); \end{cases}$       4)  $\begin{cases} \frac{y-1}{2} - \frac{y-3}{4} \geq \frac{y-2}{3} - y, \\ 1-y \geq \frac{1}{2}y-4. \end{cases}$

624. Tengsizlikning butun manfiy sondan iborat barcha yechimlarini toping:

$$\begin{cases} \frac{3x-2}{4} + 2\frac{1}{2} > \frac{2x-1}{3} - \frac{3x+2}{6}, \\ \frac{2x-5}{3} - \frac{3x-1}{2} < \frac{3-x}{5} - \frac{2x-1}{4}. \end{cases}$$

625. Kvadrat tengsizlikni yeching:

1)  $x^2 - 3x + 2 > 0$ ;      2)  $x^2 - 2x - 3 \leq 0$ ;      3)  $x^2 - 7x + 12 > 0$ ;  
 4)  $-x^2 + 3x - 1 \geq 0$ ;      5)  $3 + 4x + 8x^2 < 0$ ;      6)  $x - x^2 - 1 \geq 0$ ;  
 7)  $2x^2 - x - 1 < 0$ ;      8)  $3x^2 + x - 4 > 0$ .

626. Tengsizlikni yeching:

1)  $|x| > \frac{1}{5}$ ;      2)  $|x-1| < 2\frac{1}{3}$ ;      3)  $|x-1| > 3$ ;      4)  $|x-1| \leq 2$ .

**627.** Tengsizlikni oraliqlar usuli bilan yeching:

- 1)  $(x - 1)(x + 3) > 0$ ;                      2)  $(x + 4)(x - 2) < 0$ ;  
3)  $(x + 1,5)(x - 2)x > 0$ ;                4)  $x(x - 8)(x - 7) > 0$ ;  
5)  $(x - 1)\left(x^2 - \frac{1}{9}\right) \geq 0$ ;            6)  $(x + 3)\left(x^2 - \frac{1}{4}\right) \leq 0$ .

**628.** Sonlarni taqqoslang:

- 1)  $5\sqrt{2}$  va 7;                      2) 9 va  $4\sqrt{5}$ ;                      3)  $10\sqrt{11}$  va  $11\sqrt{10}$ ;  
4)  $5\sqrt{6}$  va  $6\sqrt{5}$ ;                5)  $3\sqrt[3]{3}$  va  $2\sqrt[3]{10}$ ;                6)  $2\sqrt[6]{3}$  va  $\sqrt{2} \cdot \sqrt[3]{5}$ .

#### 4. Tenglamalar tuzishga doir masalalar

- 629.** Ikki sonning yig'indisi 120 ga teng, ularning ayirmasi esa 5 ga teng. Shu sonlarni toping.
- 630.** Kater daryo oqimi bo'yicha yo'lga 3 soat, qaytishdagi yo'lga esa 4,5 soat vaqt sarfladi. Agar katerning suvga nisbatan tezligi 25 km/soat bo'lsa, daryo oqimining tezligi qancha?
- 631.** Motorli qayiq A dan B gacha bo'lgan yo'lni daryo oqimi bo'yicha 2,4 soatda, qaytishdagi yo'lni esa 4 soatda bosib o'tdi. Agar qayiqning suvga nisbatan tezligi 16 km/soat ekanligi ma'lum bo'lsa, daryo oqimining tezligini toping.
- 632.** Kater daryo oqimi bo'yicha 1 soatda 15 km suzdi va qaytishdagi yo'lga 1,5 soat vaqt sarflab, avvalgi joyiga qaytib keldi. Katerning suvga nisbatan tezligini va daryo oqimining tezligini toping.
- 633.** Teng yonli uchburchakning perimetri 5,4 dm ga teng. Yon tomoni asosidan 13 marta uzun. Uchburchak tomonlarining uzunliklarini toping.
- 634.** Ma'lum bir yo'nalish bo'yicha qatnaydigan yangi turdagi tramvayning tezligi eski turdagidan 5 km/soat ortiq. Shuning uchun ham u 20 km yo'lni eski turdagi tramvayga qaraganda 12 min tezroq bosib o'tadi. Yangi tramvay shu yo'lni qancha vaqtda bosib o'tadi?
- 635.** Avtobus kunning ma'lum qismida «tezyurar» (ekspres) tartibda ishlaydi. Shuning uchun ham uning tezligi bu vaqtda 8 km/soat ortadi, 16 km ga sarflanadigan vaqti esa 4 min ga qisqaradi. Avtobus tezyurar tartibda shu yo'nalishni qanday vaqtda bosib o'tadi?

636. Bir fermer-dehqon xo'jaligi o'z yer maydonidan 875 sr bug'doy, ikkinchisi esa undan 2 ga kam maydondan 920 sr bug'doy yig'ib olishdi. Agar bir gektar maydondan ikkinchi xo'jalik birinchi xo'jalikka qaraganda 5 sr ortiq bug'doy yig'ib olganligi ma'lum bo'lsa, har bir xo'jalik bir gektar maydondan qanchadan bug'doy yig'ib olgan?
637. Ikkita nasos bir vaqtda ishlaganda hovuz 2 soat 55 min da tozalanadi. Agar ulardan biri bu ishni ikkinchisiga qaraganda 2 soat tezroq bajarsa, har bir nasos alohida ishlaganda hovuzni qancha vaqtda tozalashi mumkin?

## 5. Funksiyalar va grafiklar

638. A nuqta quyida berilgan funksiyalarning grafigiga tegishli yoki tegishli emasligini aniqlang; shu funksiyalarning koordinata o'qlari bilan kesishish nuqtalari koordinatalarini va  $x = -2$  bo'lganda funksiyalarning qiymatini toping:

1)  $y = 3 - 0,5x$ ,  $A(4; 1)$ ;                      2)  $y = \frac{1}{2}x - 4$ ,  $A(6; -1)$ ;  
 3)  $y = 2,5x - 5$ ,  $A(1,5; -1,25)$ ;      4)  $y = -1,5x + 6$ ,  $A(4,6; -0,5)$ .

639. Funksiyalarning grafigini yasang (bitta koordinata tekisligida):

1)  $y = 3x$ ,  $y = -3x$ ;                              2)  $y = \frac{1}{3}x$ ,  $y = -\frac{1}{3}x$ ;  
 3)  $y = x - 2$ ,  $y = x + 2$ ;                      4)  $y = -x - 2$ ,  $y = 2 - x$ .

640. Funksiyaning grafigini yasang:

1)  $y = x^2 + 2\frac{1}{4}$ ;                      2)  $y = \left(x - \frac{1}{3}\right)^2$ ;                      3)  $y = (x + 2,5)^2 - \frac{1}{4}$ ;  
 4)  $y = x^2 - 4x + 5$ ;                      5)  $y = x^2 + 2x - 3$ ;                      6)  $y = -x^2 - 3x + 4$ .

641. Parabola uchining koordinatalarini toping:

1)  $y = x^2 - 8x + 16$ ;                              2)  $y = x^2 - 10x + 15$ ;  
 3)  $y = x^2 + 4x - 3$ ;                              4)  $y = 2x^2 - 5x + 3$ .

642. Funksiyaning eng katta va eng kichik qiymatlarini toping:

1)  $y = x^2 - 7x - 10$ ;                              2)  $y = -x^2 + 8x + 7$ ;  
 3)  $y = x^2 - x - 6$ ;                              4)  $y = 4 - 3x - x^2$ .

643. Berilgan ikkita funksiyaning bitta koordinata tekisligida grafiklarini yasang va  $x$  ning qanday qiymatlarida bu funksiyalarning qiymatlari tengligini aniqlang:

1)  $y = x^2 - 4$  va  $y = 3x$ ;                      2)  $y = (x + 3)^2 + 1$  va  $y = -x$ .

644. Grafikning xomaki tasvirini yasang va funksiyaning xossalarini ayting:

1)  $y = x^4$ ;    2)  $y = x^5$ ;    3)  $y = \frac{1}{x^3}$ ;    4)  $y = \frac{1}{x^4}$ .

645. Ifodalarning qiymatlarini taqqoslang:

1)  $\sqrt[4]{5,3}$  va  $\sqrt[4]{5\frac{1}{3}}$ ;                      2)  $\sqrt[5]{-\frac{2}{9}}$  va  $\sqrt[5]{-\frac{1}{7}}$ .

646. Funksiyaning grafigini yasang va  $x$  ning  $y = 0$ ,  $y > 0$ ,  $y < 0$  bo'ladigan qiymatlarini toping:

1)  $y = 2x^2 - 3$ ;    2)  $y = -2x^2 + 1$ ;    3)  $y = 2(x - 1)^2$ ;  
4)  $y = 2(x + 2)^2$ ;    5)  $y = 2(x - 3)^2 + 1$ ;    6)  $y = -3(x - 1)^2 + 5$ .

## 6. Trigonometriya elementlari

647. 1)  $\left(\frac{\sqrt{2}}{2}; -\frac{\sqrt{2}}{2}\right)$ ;    2)  $\left(-\frac{\sqrt{2}}{2}; -\frac{\sqrt{2}}{2}\right)$ ;    3)  $\left(-\frac{1}{2}; -\frac{\sqrt{3}}{2}\right)$ ;    4)  $\left(-\frac{\sqrt{3}}{2}; -\frac{1}{2}\right)$

koordinatali nuqta hosil qilish uchun  $P(1; 0)$  nuqtani burish kerak bo'lgan barcha burchaklarni toping.

648. Ifodani soddalashtiring:  $(1 + \operatorname{tg}\alpha)(1 + \operatorname{ctg}\alpha) - \frac{1}{\sin \alpha \cos \alpha}$ .

649. Ayniyatni isbotlang:

1)  $\frac{1 - (\sin \alpha + \cos \alpha)^2}{\sin \alpha \cos \alpha - \operatorname{ctg}\alpha} = 2\operatorname{tg}^2 \alpha$ ;    2)  $\frac{\operatorname{tg}\alpha - \sin \alpha \cos \alpha}{(\sin \alpha - \cos \alpha)^2 - 1} = -\frac{1}{2} \operatorname{tg}^2 \alpha$ .

650. Ifodani soddalashtiring:

1)  $\sin^2(\alpha + 8\pi) + \cos(\alpha + 10\pi)$ ;    2)  $\cos^2(\alpha + 6\pi) + \cos^2(\alpha - 4\pi)$ .

651. Ifodani soddalashtiring:  $\frac{\sin 2\alpha}{2(1 - 2\cos^2 \alpha)} + \frac{\sin \alpha \cos(\pi - \alpha)}{1 - 2\sin^2 \alpha}$ .

652. Ayniyatni isbotlang:  $\frac{\cos^2 x}{1 - \sin x} - \frac{\sin^2 x}{1 + \cos x} = \sin x + \cos x$ .

653. 1) agar  $\cos \alpha = -\frac{\sqrt{3}}{3}$  va  $\frac{\pi}{2} < \alpha < \pi$  bo'lsa,  $\sin 2\alpha$  ni hisoblang;

2) agar  $\sin \alpha = \frac{1}{3}$  bo'lsa,  $\cos 2\alpha$  ni hisoblang.

654. Ifodaning qiymatini toping:

$$1) \cos 765^\circ - \sin 750^\circ - \cos 1035^\circ; \quad 2) \sin \frac{11\pi}{3} + \cos 690^\circ - \cos \frac{19\pi}{3}.$$

655. Agar  $\operatorname{tg} \alpha = 2$  bo'lsa, ifodaning qiymatini toping:

$$1) \frac{\sin^2 \alpha + \sin \alpha \cos \alpha}{\cos^2 \alpha + 3 \cos \alpha \sin \alpha}; \quad 2) \frac{2 - \sin^2 \alpha}{3 + \cos^2 \alpha}.$$

656.  $\operatorname{tg} \alpha + \operatorname{ctg} \alpha = 3$  ekanligi ma'lum.  $\operatorname{tg}^2 \alpha + \operatorname{ctg}^2 \alpha$  ni toping.

657. Ifodani soddalashtiring:

$$1) \frac{\cos \alpha + \sin \alpha}{\cos \alpha - \sin \alpha} - \operatorname{tg} \left( \frac{\pi}{4} + \alpha \right); \quad 2) \operatorname{tg}^2 \left( \frac{\pi}{4} - \alpha \right) - \frac{1 - \sin 2\alpha}{1 + \sin 2\alpha}.$$

658. Ifodani soddalashtiring:  $\frac{\cos 2\alpha - \sin 2\alpha - 2 \cos^2 \alpha}{\cos(-\alpha) - \cos(2,5\pi + \alpha)}$ .

## 7. Progressiyalar

659. Agar  $a_1 = 7$ ,  $a_7 = -5$  bo'lsa, arifmetik progressiyaning ayirmasini toping.

660. Agar  $a_{10} = 4$ ,  $d = 0,5$  bo'lsa, arifmetik progressiyaning birinchi hadini toping.

661. Agar: 1)  $a_n = 459$ ,  $d = 10$ ,  $n = 45$ ; 2)  $a_n = 121$ ,  $d = -5$ ,  $n = 17$  bo'lsa, arifmetik progressiyaning birinchi hadini va dastlabki  $n$  ta hadining yig'indisini hisoblang.

662. Agar arifmetik progressiyada  $a_1 = -2$ ,  $a_5 = -6$ ,  $a_n = -40$  bo'lsa,  $n$  nomerni toping.

663.  $b_{n+1} = -\frac{b_n}{2}$  formula va  $b_1 = 1024$  shart bilan berilgan ketma-ketlikning dastlabki o'n ta hadining yig'indisini toping.

664. Agar geometrik progressiyada:

$$1) b_1 = 5, q = -10 \text{ va } b_n = -5000 \text{ bo'lsa, } n \text{ ni};$$

$$2) b_3 = 16 \text{ va } b_6 = 2 \text{ bo'lsa, } q \text{ ni};$$

$$3) b_3 = 16 \text{ va } b_6 = 2 \text{ bo'lsa, } b_1 \text{ ni};$$

$$4) b_3 = 16 \text{ va } b_6 = 1 \text{ bo'lsa } b_7 \text{ ni toping.}$$

665. Agar  $3 + 6 + 12 + \dots + 96$  yig'indining qo'shiluvchilari geometrik progressiyaning ketma-ket hadlari bo'lsa, shu sonlar yig'indisini toping.



666. Agar: 1)  $a_3 = 25, a_{10} = -3$ ; 2)  $a_1 = 10, a_7 = 19$ ;  
 3)  $a_3 + a_7 = 4, a_2 + a_{14} = -8$ ; 4)  $a_2 + a_4 = 16, a_1 \cdot a_5 = 28$ ;  
 bo'lsa, arifmetik progressiyaning birinchi hadini va ayirmasini toping.
667. Agar: 1)  $a_9 = -5$  va  $a_{11} = 7$ ; 2)  $a_9 + a_{11} = -10$ ; 3)  $a_9 + a_{10} + a_{11} = 12$   
 bo'lsa, arifmetik progressiyaning o'ninchi hadini toping.
668.  $S_7 = -35$  va  $S_{42} = -1680$  bo'lsa, arifmetik progressiyaning birinchi hadini va ayirmasini toping.
669.  $n$ -hadining formulasi bilan berilgan ketma-ketlik geometrik progressiya bo'la oladimi:  
 1)  $b_n = -3^{2n}$ ; 2)  $b_n = 2^{3n}$ ; 3)  $h_n = \frac{3}{2n}$ ; 4)  $h_n = \frac{(-1)^n}{2^n}$ ?
670. Agar: 1)  $b_1 = 12, S_3 = 372$ ; 2)  $b_1 = 1, S_3 = 157$ ;  
 bo'lsa, geometrik progressiyaning maxrajini hisoblang.
671. Agar  $b_2 = -\frac{1}{2}$  va  $b_4 = -\frac{1}{72}$  bo'lsa, geometrik progressiyaning birinchi hadini, maxrajini va  $n$ -hadining formulasini toping.
672. Agar  $b_3 = -6$  va  $b_5 = -24$  bo'lsa, geometrik progressiyaning to'rtinchi hadini va maxrajini toping.
673.  $\frac{1}{3}$  va 27 sonlari orasiga uchta sonni shunday joylashtiringki, natijada geometrik progressiyaning ketma-ket beshta hadi hosil bo'lsin.
674. Agar geometrik progressiyada:  
 1)  $q = 3, S_3 = 484$  bo'lsa,  $b_1$  va  $b_3$  ni toping;  
 2)  $b_3 = 0,024, S_3 = 0,504$  bo'lsa,  $b_1$  va  $q$  ni toping.
675. Agar:  
 1)  $b_1 + b_2 = 20, b_2 + b_3 = 60$ ; 2)  $b_1 + b_2 = 60, b_1 + b_3 = 51$   
 bo'lsa, geometrik progressiyaning birinchi hadini va maxrajini hisoblang.
676. Agar geometrik progressiyada:  
 1)  $b_4 = 88, q = 2$  bo'lsa,  $S_5$  ni; 2)  $S_5 = 341, q = 2$  bo'lsa,  $b_1$  ni;  
 3)  $b_1 = 11, b_4 = 88$  bo'lsa,  $S_5$  ni; 4)  $b_3 = 44, b_5 = 176$  bo'lsa,  $S_5$  ni toping.

## Sonlar va ifodalar

### 1. Son.

*Natural* sonlar to‘plami: 1, 2, 3 ... .

*Butun* sonlar to‘plami: 0;  $\pm 1$ ;  $\pm 2$ ;  $\pm 3$ ; ... .

*Ratsional* sonlar to‘plami —  $\frac{m}{n}$  ko‘rinishidagi sonlar, bunda  $m$  —

butun son,  $n$  — natural son. Masalan,  $\frac{3}{5}$ ; 2;  $\frac{2}{7}$  sonlar ratsional sonlardir.

Ratsional sonni chekli o‘nli kasr yoki cheksiz davriy o‘nli kasr shaklida tasvirlash mumkin. Masalan,

$$\frac{2}{5} = 0,4; -\frac{1}{3} = -0,333 = -0,(3).$$

*Irratsional sonlar to‘plami* cheksiz nodavriy o‘nli kasrlar to‘plamidir. Masalan, 0,1001000100001... — irratsional son.

Shuningdek,  $\sqrt{2}$ ,  $\sqrt{3}$ ,  $\sqrt{5}$  sonlari ham irratsional sonlar bo‘ladi.

*Haqiqiy sonlar to‘plami* — ratsional va irratsional sonlar to‘plami.

**2. Sonli oraliqlar** — kesmalar, intervallar, yarim intervallar, nur-lar.

$[a; b]$  kesma  $a \leq x \leq b$  tengsizliklarni qanoatlantiruvchi  $x$  sonlar to‘plami, bunda  $a < b$ . Masalan,  $[2; 5]$  kesma — bu  $2 \leq x \leq 5$  tengsizlikni qanoatlantiruvchi  $x$  sonlar to‘plami.

$(a; b)$  interval (oraliq)  $a < x < b$  tengsizlikni qanoatlantiruvchi  $x$  sonlar to‘plami, bunda  $a < b$ . Masalan,  $(-2; 3)$  interval — bu  $-2 < x < 3$  tengsizlikni qanoatlantiruvchi  $x$  sonlar to‘plami.

$[a; b)$  yarim interval  $a \leq x < b$  tengsizlikni qanoatlantiruvchi  $x$  sonlar to‘plami,  $(a; b]$  yarim interval esa  $a < x \leq b$  tengsizlikni qanoatlantiruvchi  $x$  sonlar to‘plami,  $a < b$ . Masalan,  $[3; 8)$  yarim interval  $3 \leq x < 8$  tengsizlikni qanoatlantiruvchi  $x$  sonlar to‘plami.  $(-4; 2]$  esa  $-4 < x \leq 2$  tengsizlikni qanoatlantiruvchi sonlar to‘plami.

Nur  $x > a$ , yoki  $x < a$ , yoki  $x \geq a$ ,  $x \leq a$  tengsizlikni qanoatlantiruvchi  $x$  sonlar to‘plami. Masalan,  $x \geq 5$  nur 5 dan katta sonlar to‘plami.

**3.  $a$  sonning moduli** ( $|a|$  kabi belgilanadi) quyidagi formula bilan ta'riflanadi:

$$|a| = \begin{cases} a, & \text{agar } a \geq 0 \text{ bo'lsa,} \\ -a, & \text{agar } a < 0 \text{ bo'lsa.} \end{cases}$$

Geometrik nuqtayi nazardan  $|a|$  — bu 0 nuqtadan  $a$  sonni tasvirlovchi nuqttagacha bo'lgan masofa;  $|a - b|$  — bu  $a$  va  $b$  nuqtalar orasidagi masofadir.

Istalgan  $a$  son uchun  $|a| \geq 0$  tengsizlik bajariladi, bunda faqat  $a = 0$  bo'lgandagina  $|a| = 0$  bo'ladi.

$|x| \leq a$  tengsizlikni (bunda  $a > 0$ )  $[-a; a]$  kesmadagi  $x$  nuqtalar, ya'ni  $-a \leq x \leq a$  tengsizlikni qanoatlantiruvchi  $x$  sonlar qanoatlantiradi.

$|x| < a$  tengsizlikni (bunda  $a > 0$ )  $(-a; a)$  interval (oraliq)dagi  $x$  sonlar, ya'ni  $-a < x < a$  tengsizlikni qanoatlantiruvchi  $x$  sonlar qanoatlantiradi.

$|x| \geq a$  tengsizlikni (bunda  $a > 0$ ) barcha  $x \leq -a$  va  $x \geq a$  sonlar qanoatlantiradi.

$|x| > a$  tengsizlikni (bunda  $a > 0$ ) barcha  $x < -a$  va  $x > a$  sonlar qanoatlantiradi.

**4. Sonli ifodalar** — amallar ishoralari bilan birlashtirilgan sonlardan tuzilgan yozuv.

Masalan,  $1,2 \cdot (-3) - 9 : 0,5$  — sonli ifoda.

*Sonli ifodaning qiymati* — shu ifodada ko'rsatilgan amallarni bajarish natijasida hosil bo'lgan son. Masalan,  $-21,6$  soni  $1,2 \cdot (-3) - 9 : 0,5$  ifodaning qiymati.

**5. Amallarni bajarish tartibi.**

*Birinchi bosqich amallar* — qo'shish va ayirish.

*Ikkinchi bosqich amallar* — ko'paytirish va bo'lish.

*Uchinchi bosqich amal* — darajaga ko'tarish.

1) agar ifodada qavslar ishtirok etmasa, avval uchinchi bosqich amallar bajariladi, so'ngra ikkinchi bosqich va oxirida birinchi bosqich amallar bajariladi: bunda ayni bir xil bosqichlarga doir amallar ular qanday tartibda yozilgan bo'lsa, xuddi shunday tartibda bajariladi;

2) agar ifoda qavslardan tuzilgan bo'lsa, avval qavs ichidagi sonlar ustidagi barcha amallar bajariladi, so'ngra esa qolgan amallar bajariladi; bunda qavs ichidagi va qavsdan tashqaridagi amallar 1-bandda ko'rsatilgan tartibda bajariladi;

3) agar kasr ifodaning qiymati hisoblanayotgan bo'lsa, u holda kasrning surati va maxrajidagi amallar alohida bajariladi va birinchi natijani ikkinchisiga bo'linadi;

4) agar ifoda boshqa qavslar ichida joylashgan qavslardan tashkil topgan bo'lsa, u holda avval ichki qavslardagi amallar bajariladi.

**6. Sonning standart shakli**, bu  $a \cdot 10^n$  kabi ko'rinishdagi yozuv, bunda  $1 \leq |a| < 10$ ,  $n$  - butun son,  $a$  - sonning mantissasi,  $n$  - sonning tartibi. Masalan,  $345,4 = 3,454 \cdot 10^2$ ,  $0,003 = 3 \cdot 10^{-3}$ ,  $-0,12 = -1,2 \cdot 10^{-1}$ .

### 7. Yaqinlashish xatoligi.

*Yaqinlashishning absolut xatoligi* — kattalikning aniq qiymati bilan uning taqribiy qiymati orasidagi ayirmaning moduli. Agar  $a$  — taqribiy son,  $x$  esa aniq son bo'lsa, u holda absolut xatolik  $|x - a|$  ga teng.

$x = a \pm h$  yozuvi yaqinlashishning absolut xatoligi  $h$  dan ortib ketmasligini bildiradi, ya'ni  $|x - a| \leq h$  yoki  $a - h \leq x \leq a + h$ . Bunda  $x$  son  $a$  ga  $h$  gacha aniqlik bilan teng deyiladi. Masalan,  $\pi = 3,14 \pm 0,01$  yozuvi  $|\pi - 3,14| \leq 0,01$ , ya'ni  $\pi$  soni 3,14 ga 0,01 gacha aniqlik bilan tengligini bildiradi.

*Sonni kami bilan  $10^{-n}$  gacha aniqlikda yaxlitlashda* verguldan keyingi dastlabki  $n$  ta belgi saqlanib qoladi, keyingilari esa tashlab yuboriladi. Masalan, 17,2397 sonini kami bilan mingliklargacha, ya'ni  $10^{-3}$  gacha aniqlikda yaxlitlashda 17,239, yuzliklargacha yaxlitlashda 17,23, o'nliklargacha yaxlitlashda 17,2 hosil qilinadi.

*Sonni ortig'i bilan  $10^{-n}$  gacha yaxlitlashda* verguldan keyingi  $n$ -belgi (raqam) bir birlikka orttiriladi, keyingi barcha belgilar esa tashlab yuboriladi. Masalan, 2,5143 sonini ortig'i bilan mingliklargacha aniqlikda yaxlitlashda 2,515, yuzliklargacha yaxlitlashda 2,52, o'nliklargacha yaxlitlashda 2,6 hosil qilinadi.

Ikkala holda ham yaxlitlash xatoligi  $10^{-n}$  dan ortmaydi.

*Eng kichik xatolik bilan yaxlitlash:* agar berilgan sonning birinchi tashlab yuboriladigan raqami 5 dan kichik bo'lsa, u holda kami bilan yaxlitlanadi, bordi-yu, bu raqam 5 dan katta yoki unga teng bo'lsa, ortig'i bilan yaxlitlanadi. Masalan, 8,351 sonini yuzliklargacha yaxlitlashda 8,35 ni, o'nliklargacha yaxlitlashda esa 8,4 ni hosil qilamiz.

$x \approx a$  yozuvi  $a$  son  $x$  sonning taqribiy qiymati ekanligini bildiradi.

Masalan,  $\sqrt{2} \approx 1,4$ .

Nisbiy xatolik absolut xatolikni miqdorning taqribiy qiymati moduliga nisbati (bo'linmasi). Agar  $x$  - aniq qiymat,  $a$  - taqribiy qiymat

bo'lsa, u holda nisbiy xatolik  $\frac{|x-a|}{|a|}$  ga teng bo'ladi.

Nisbiy xatolik odatda protsentlarda ifodalanadi. Masalan, agar miqdorning aniq qiymati 1,95 ga teng, taqribiy qiymati 2 ga teng bo'lsa, u holda yaqinlashishining nisbiy xatoligi

$$\frac{|2-1,95|}{2} = \frac{|0,05|}{2} = 0,25 \text{ yoki } 2,5\%.$$

## Algebraik ifodalar

**8. Algebraik ifoda** — amallar ishoralari bilan birlashtirilgan sonlar va harflardan tuzilgan ifoda. Algebraik ifodalarga misollar:

$$2(m+n); 3a+2ab-1; (a-b)^2; \frac{2x+y}{z}.$$

*Algebraik ifodaning qiymati* — bu ifodadagi harflar sonlar bilan almashtirilgandan keyin qilingan hisoblash natijasidagi son. Masalan,  $a=2$  va  $b=3$  bo'lganda  $3a+2ab-1$  ifodaning son qiymati  $3 \cdot 2 + 2 \cdot 2 \cdot 3 - 1 = 17$  bo'ladi.

**9. Algebraik yig'indi** — «+» yoki «-» ishoralari bilan birlashtirilgan bir nechta algebraik ifodalardan tuzilgan yozuv.

*Qavslarni ochish tartibi.*

1) Agar algebraik ifodaga qavs ichiga olingan algebraik yig'indi qo'shilsa, u holda shu algebraik yig'indidagi har bir qo'shiluvchining ishorasini saqlagan holda qavslarni tashlab yuborish mumkin, masalan,

$$14 + (7 - 23 + 21) = 14 + 7 - 23 + 21, \\ a + (b - c - d) = a + b - c - d.$$

2) Agar algebraik ifodadan qavs ichiga olingan algebraik yig'indi ayirilsa, u holda shu algebraik yig'indidagi har bir qo'shiluvchining ishorasini qarama-qarshisiga almashtirilib, qavslarni tashlab yuborish mumkin, masalan,

$$14 - (7 - 23 + 21) = 14 - 7 + 23 - 21, \\ a - (b - c - d) = a - b + c + d.$$

**10. Birhad** — sonli va harfiy ko'paytuvchilarning ko'paytmasidan iborat algebraik ifoda.

Birhadlarga misollar:  $3ab$ ,  $-2ab^2c^3$ ,  $a^2$ ,  $a$ ,  $0,6xy^5y^2$ ,  $-t^4$ .

Masalan,  $3a^2(0,4) \cdot b(-5)c^3$  birhadning sonli ko'paytuvchilari 3; 0,4; -5, harfiy ko'paytuvchilari esa  $a^2$ ,  $b$ ,  $c^3$ .

*Standart shakldagi birhad* — birinchi o'rinda turgan faqat bitta sonli ko'paytuvchidan va har xil harfiy asosli darajalardan tuzilgan birhad.

Birhadni standart shaklda yozish uchun uning hamma sonli ko'paytuvchilarini o'zaro ko'paytirish va natijani birinchi o'ringa qo'yish, so'ngra bir xil harfiy ko'paytuvchilarning ko'paytmasini daraja shaklida yozish kerak.

*Birhadning koeffitsiyenti* – standart shaklda yozilgan birhadning son ko'paytuvchisi.

Masalan,  $\frac{3}{4}abc^2$  birhadning koeffitsiyenti  $\frac{3}{4}$  ga teng,  $-7a^3b$  birhadning koeffitsiyenti  $-7$  ga teng,  $a^2bc$  birhadning koeffitsiyenti  $1$  ga teng,  $-ab^2$  birhadning koeffitsiyenti  $-1$  ga teng.

**11. Ko'phad** — bir nechta birhadlarning algebraik yig'indisi.

Ko'phadga misollar:

$4ab^2c^3$  – birhad,  $2ab - 3bc$  – ikkihad,  $4ab + 3ac - bc$  – uchhad.

*Ko'phadning hadlari* – ko'phadni tashkil qiluvchi birhadlar. Masalan,  $2ab^2 - 3a^2c + 7bc - 4bc$  ko'phadning hadlari  $2ab^2$ ,  $-3a^2c$ ,  $7bc$ ,  $-4bc$  bo'ladi.

*O'xshash hadlar* – faqat koeffitsiyentlari bilan farq qiluvchi birhadlar yoki bir xil birhadlar.

*O'xshash hadlarni ixchamlash* – ko'phadni soddalashtirish, bunda o'xshash birhadlarning algebraik yig'indisi bitta birhad bilan almashtiriladi. Masalan:

$$2ab - 4bc + ac + 3ab + bc = 5ab - 3bc + ac.$$

*Ko'phadning standart shakli* – ko'phadning hamma hadlari standart shaklda yozilgan va ularning orasida o'xshash hadlar bo'lmagan yozuvi.

*Birhadlar va ko'phadlar ustida amallar:*

1) bir nechta ko'phadlarning algebraik yig'indisini standart shakldagi ko'phad ko'rinishida yozish uchun qavslarni ochish va o'xshash hadlarni ixchamlash kerak, masalan,

$$\begin{aligned} & (2a^2b - 3bc) + (a^2b + 5bc) - (3a^2b - bc) = \\ & = 2a^2b - 3bc + a^2b + 5bc - 3a^2b + bc = 3bc. \end{aligned}$$

2) ko'phadni birhadga ko'paytirish uchun ko'phadning har bir hadini shu birhadga ko'paytirish va hosil bo'lgan ko'paytmalarni qo'shish kerak, masalan,

$$(2ab - 3bc)(4ac) = (2ab)(4ac) + (-3bc)(4ac) = 8a^2bc - 12abc^2.$$

3) ko'phadni ko'phadga ko'paytirish uchun birinchi ko'phadning har bir hadini ikkinchi ko'phadning har bir hadiga ko'paytirish va hosil bo'lgan ko'paytmalarni qo'shish kerak. Masalan,

$$(5a - 2b)(3a + 4b) = (5a)(3a) + (5a)(4b) + (-2b)(3a) + (-2b)(4b) = 15a^2 + 14ab - 8b^2.$$

4) ko'phadni birhadga bo'lish uchun ko'phadning har bir hadini shu birhadga bo'lish va hosil bo'lgan natijalarni qo'shish kerak, masalan,

$$(4a^3b^2 - 12a^2b^3) : (2ab) = (4a^3b^2) : (2ab) + (-12a^2b^3) : (2ab) = 2a^2b - 6ab^2.$$

## 12. Qisqa ko'paytirish formulalari.

$$1) (a + b)^2 = a^2 + 2ab + b^2;$$

$$2) (a - b)^2 = a^2 - 2ab + b^2;$$

$$3) (a + b)^3 = a^3 + 3a^2b + 3b^2a + b^3;$$

$$4) (a - b)^3 = a^3 - 3a^2b + 3ab^2 - b^3;$$

$$5) a^2 - b^2 = (a + b)(a - b);$$

$$6) a^3 + b^3 = (a + b)(a^2 - ab + b^2);$$

$$7) a^3 - b^3 = (a - b)(a^2 + ab + b^2).$$

13. Ko'phadni ko'paytuvchilarga ajratish - ko'phadni ikki yoki bir nechta ko'phadlarning ko'paytmasi shaklida ifodalash, masalan,

$4x^2 - 9y^2 = (2x + 3y)(2x - 3y)$ . Ko'phadni ko'paytuvchilarga ajratishda quyidagi *usullardan* foydalaniladi.

1) *Umumiy ko'paytuvchini qavsdan tashqariga chiqarish*. Masalan,  $3ax + 6ay = 3a(x + 2y)$ .

2) *Guruhlash usuli*. Masalan,

$$\begin{aligned} a^3 - 2a^2 - 2a + 4 &= (a^3 - 2a^2) - (2a - 4) = \\ &= a^2(a - 2) - 2(a - 2) = (a - 2)(a^2 - 2). \end{aligned}$$

3) *Qisqa ko'paytirish formulalarini qo'llash*. Masalan,

$$\begin{aligned} 9x^2 - \frac{1}{16}y^2 &= (3x + \frac{1}{4}y)(3x - \frac{1}{4}y); \\ 27x^3 + 8y^6 &= (3x + 2y^2)(9x^2 - 6xy^2 + 4y^4); \\ z^2 - 14z + 49 &= (z - 7)^2. \end{aligned}$$

Kvadrat uchhadni ko'paytuvchilarga ajratish - uni  $ax^2 + bx + c = a(x - x_1)(x - x_2)$  kabi ko'rinishda tasvirlash, bunda  $x_1$  va  $x_2$  lar  $ax^2 + bx + c = 0$  kvadrat tenglamaning ildizlari. Masalan,

$$2x^2 + 3x - 2 = 2\left(x - \frac{1}{2}\right)(x + 2).$$

**14. Algebraik kasr** - surati va maxraji algebraik ifodalardan iborat kasr.

Algebraik kasrlarga misollar:  $\frac{a^2+b}{c}$ ,  $\frac{3x-2y}{a+1}$ . Algebraik kasr yozuvida qo'llanilgan harflar faqat shu kasrning maxraji nolga teng bo'lmaydigan qiymatlarni qabul qilishi mumkin, deb faraz qilinadi.

*Kasrning asosiy xossasi*: surat va maxrajini ayni bir xil algebraik ifodaga ko'paytirganda unga teng kasr hosil bo'ladi. Masalan,

$$\frac{a-b}{a+b} = \frac{(a-b)(a-b)}{(a+b)(a-b)} = \frac{(a-b)^2}{a^2-b^2}.$$

Kasrning asosiy xossasidan foydalanib, algebraik kasrni uning surat va maxrajining umumiy ko'paytuvchisiga qisqartirish mumkin. Masalan,

$$\frac{x^2-1}{x^3-1} = \frac{(x-1)(x+1)}{(x-1)(x^2+x+1)} = \frac{x+1}{x^2+x+1}.$$

*Algebraik kasrlarni qo'shish va ayirish* sonli kasrlar uchun qo'llaniladigan qoidalar bo'yicha olib boriladi.

Ikki yoki bir nechta kasrlarning algebraik yig'indisini topish uchun bu kasrlarni umumiy maxrajga keltiriladi va bir xil maxrajli kasrlarni qo'shish qoidasidan foydalaniladi.

Masalan,  $\frac{1}{a^2b}$  va  $\frac{1}{ab^2}$  kasrlarning umumiy maxraji  $a^2b^2$  ga teng, shuning uchun

$$\frac{1}{a^2b} + \frac{1}{ab^2} = \frac{b}{a^2b^2} + \frac{a}{a^2b^2} = \frac{b+a}{a^2b^2}.$$

*Algebraik kasrlarni ko'paytirish va bo'lish* sonli kasrlar uchun qo'llanilgan qoidalar bo'yicha olib boriladi, masalan,

$$\frac{2a}{3b} \cdot \frac{b^2}{4a} = \frac{2ab^2}{3b \cdot 4a} = \frac{1}{6}b; \quad \frac{x^2-y^2}{2xy} : \frac{x+y}{4x} = \frac{(x^2-y^2) \cdot 4x}{2xy(x+y)} = \frac{2(x-y)}{y}.$$



**15. Ayniyat** – unga kirgan harflarning joiz qiymatlarida to'g'ri bo'lgan tenglik. Masalan, quyidagi tengliklar ayniyat bo'ladi:

$$a^2 - b^2 = (a - b)(a + b); \quad \sqrt{a^2} = |a|,$$

$$\sin^2 \alpha + \cos^2 \alpha = 1, \quad \frac{a^2 - 1}{a - 1} = a + 1.$$

## DARAJALAR VA ILDIZLAR

**16.  $a$  sonning 1 dan katta bo'lgan  $n$  natural ko'rsatkichli darajasi**, bu  $a$  ga teng  $n$  ta ko'paytuvchining ko'paytmasi, ya'ni,

$$a^n = \underbrace{a \cdot a \cdot \dots \cdot a}_{n \text{ marta}}.$$

Masalan,  $2^3 = 2 \cdot 2 \cdot 2$ ,  $m^5 = \underbrace{m \cdot m \cdot m \cdot m \cdot m}_{5 \text{ marta}}$ .

Darajaning  $a^n$  yozuvida  $a$  son – darajaning asosi,  $n$  – daraja ko'rsatkichi. Masalan,  $2^3$  yozuvida 2 soni – darajaning asosi, 3 soni – daraja ko'rsatkichi.

*Sonning birinchi darajasi* – sonning o'zi:  $a^1 = a$ . Masalan,

$$3^1 = 3, \quad \left(\frac{1}{13}\right)^1 = \frac{1}{13}.$$

*Darajaga ko'tarish amali* sonning darajasini topishdir.

*Darajalarning asosiy xossalari:*

1) teng asosli darajalarni ko'paytirishda asos avvalgicha qoladi, daraja ko'rsatkichlari esa qo'shiladi:

$$a^n \cdot a^m = a^{n+m};$$

2) teng asosli darajalarni bo'lishda asos avvalgicha qoladi, daraja ko'rsatkichlari esa ayiriladi:

$$a^n : a^m = a^{n-m};$$

3) darajani darajaga ko'tarishda asos avvalgicha qoladi, daraja ko'rsatkichlari esa o'zaro ko'paytiriladi:

$$(a^n)^m = a^{nm};$$

4) ko'paytmani darajaga ko'tarishda har bir ko'paytuvchi shu darajaga ko'tariladi:

$$(a \cdot b)^n = a^n \cdot b^n;$$

5) kasrni darajaga ko'tarishda uning surat va maxraji shu darajaga ko'tariladi:

$$\left(\frac{a}{b}\right)^n = \frac{a^n}{b^n}.$$

**17.  $a$  sonidan kvadrat ildiz** – kvadrati  $a$  ga teng bo'lgan son. Masalan, 6 – bu 36 sonidan kvadrat ildiz;  $-6$  soni ham 36 sonidan kvadrat ildiz.

*Kvadrat ildiz chiqarish* – kvadrat ildizni topish amali. Faqat nomanfiy sonidan kvadrat ildiz chiqarish mumkin.

$a$  sonidan olingan (chiqarilgan) *arifmetik kvadrat ildiz* – kvadrati  $a$  ga teng bo'lgan nomanfiy son. Bu son bunday belgilanadi:  $\sqrt{a}$ . Masalan,  $\sqrt{16} = 4$ ,  $\sqrt{144} = 12$ .

$\sqrt{a}$  ifoda faqat  $a \geq 0$  bo'lganda ma'noga ega, bunda

$$\sqrt{a} \geq 0, (\sqrt{a})^2 = a.$$

Kvadrat ildizlarning xossalari:

1) agar  $a \geq 0$ ,  $b \geq 0$  bo'lsa, u holda  $\sqrt{ab} = \sqrt{a} \cdot \sqrt{b}$  bo'ladi. Masalan,  $\sqrt{144 \cdot 196} = \sqrt{144} \cdot \sqrt{196} = 12 \cdot 14 = 168$ .

2) Agar  $a \geq 0$ ,  $b > 0$  bo'lsa, u holda  $\sqrt{\frac{a}{b}} = \frac{\sqrt{a}}{\sqrt{b}}$  bo'ladi. Masalan,  $\sqrt{\frac{169}{225}} = \frac{\sqrt{169}}{\sqrt{225}} = \frac{13}{15}$ .

3) Agar  $a \geq 0$ ,  $n$  – natural son bo'lsa,  $\sqrt{a^{2n}} = a^n$  bo'ladi. Masalan,  $\sqrt{3^6} = 3^3 = 27$ .

Bu xossalardan kvadrat ildizlar qatnashgan ifodalarni almashtirishda foydalaniladi. Bu almashtirishlardan asosiylari:

*ko'paytuvchini ildiz belgisi ostidan chiqarish:*

agar  $a \geq 0$ ,  $b \geq 0$  bo'lsa, u holda  $\sqrt{a^2 b} = a\sqrt{b}$  bo'ladi;

*ko'paytuvchini ildiz belgisi ostida kiritish:*

agar  $a \geq 0$ ,  $b \geq 0$  bo'lsa, u holda  $a\sqrt{b} = \sqrt{a^2 b}$  bo'ladi.

## TENGLAMALAR

**18. Bir noma'lumli tenglama** – harf bilan belgilangan noma'lumli o'z ichiga olgan tenglik.

Tenglamaga misol:  $2x + 3 = 3x + 2$ , bunda  $x$  – topilishi kerak bo'lgan noma'lum son.

*Tenglamaning ildizi* – noma'lumning tenglamani to'g'ri tenglikka aylantiruvchi qiymati.

Masalan, 3 soni  $x + 1 = 7 - x$  tenglamaning ildizi, chunki  $3 + 1 = 7 - 3$ .

*Tenglamani yechish* – uning barcha ildizlarini topish yoki ularning yo'qligini isbotlash demakdir.

*Tenglamalarning asosiy xossalari:*

1) tenglamaning istagan hadini uning bir qismidan ikkinchi qismiga qarama-qarshi ishora bilan olib o'tish mumkin.

2) tenglamaning ikkala qismini nolga teng bo'lmagan ayni bir songa ko'paytirish yoki bo'lish mumkin.

**19. Kvadrat tenglama**, bu  $ax^2 + bx + c = 0$  ko'rinishdagi tenglama, bunda  $a$ ,  $b$  va  $c$  – berilgan sonlar, shu bilan birga  $a \neq 0$ ,  $x$  – noma'lum son.

Kvadrat tenglamaning koeffitsiyentlari quyidagicha ataladi:  $a$  – birinchi yoki bosh koeffitsiyent,  $b$  – ikkinchi koeffitsiyent,  $c$  – ozod had.

Kvadrat tenglamaga misollar:  $2x^2 - x - 1 = 0$ ,  $3x^2 + 7x = 0$ .

*Chala kvadrat tenglama* ham  $ax^2 + bx + c = 0$  ko'rinishdagi kvadrat tenglama, ammo unda  $b$  yoki  $c$  koeffitsiyentlardan aqalli bittasi nolga teng bo'ladi.

Chala kvadrat tenglamalarga misollar:  $x^2 = 0$ ,  $5x^2 + 4 = 0$ ,  $8x^2 + x = 0$ .

*Kvadrat tenglama ildizlarining formulasi:*  $x_{1,2} = \frac{-b \pm \sqrt{b^2 - 4ac}}{2a}$ .

Masalan,  $3x^2 + 5x - 2 = 0$  tenglama ikkita ildizga ega:

$$x_{1,2} = \frac{-5 \pm \sqrt{25 + 24}}{6} = \frac{-5 \pm 7}{6}, \text{ ya'ni } x_1 = \frac{1}{3}, x_2 = -2.$$

*Keltirilgan kvadrat tenglama*  $x^2 + px + q = 0$  ko'rinishdagi tenglama. Keltirilgan kvadrat tenglama ildizlarining formulasi:

$$x_{1,2} = -\frac{p}{2} \pm \sqrt{\frac{p^2}{4} - q}.$$

Masalan,  $x^2 - 6x - 7 = 0$  tenglamaning ildizlari:

$$x_{1,2} = 3 \pm \sqrt{9+7} = 3 \pm 4, \text{ ya'ni } x_1 = 7, x_2 = -1.$$

*Viyet teoremasi.* Keltirilgan kvadrat tenglama ildizlarining yig'indisi qarama-qarshi ishora bilan olingan ikkinchi koeffitsiyentga, ularning ko'paytmasi esa ozod hadga teng.

Shunday qilib, agar  $x_1$  va  $x_2$  lar sonlar  $x^2 + px + q = 0$  kvadrat tenglamaning ildizlari bo'lsa, u holda  $x_1 + x_2 = -p$ ,  $x_1 \cdot x_2 = q$  bo'ladi.

*Viyet teoremasiga teskari teorema.* Agar  $p$ ,  $q$ ,  $x_1$ ,  $x_2$  sonlar uchun  $x_1 + x_2 = -p$ ,  $x_1 x_2 = q$  tengliklar o'rinli bo'lsa, u holda  $x_1$  va  $x_2$  sonlar  $x^2 + px + q = 0$  tenglamaning ildizlari bo'ladi.

**20. Ikki noma'lumli ikkita tenglama sistemasini** – birgalikda qaraladigan  $x$  va  $y$  noma'lumli ikkita tenglama.

Ikki noma'lumli ikkita tenglama sistemasiga misol:

$$\begin{cases} 3x - y = 5, & x - 2y = 7, \\ 2x + y = 7; & x^2 - 4y^2 = -35. \end{cases}$$

*Sistemaning yechimi* – shu sistemaga qo'yganda uning har bir tenglamasini to'g'ri tenglikka aylantiradigan  $x$  va  $y$  sonlar jufti.

Masalan, ushbu  $\begin{cases} 4x - y = 2, \\ 5x + y = 7 \end{cases}$  sistemaning yechimi  $x = 1$ ,  $y = 2$  sonlar jufti bo'ladi.

*Sistemani yechish* – uning barcha yechimlarini topish yoki ularning yo'qligini isbotlash demakdir.

Tenglamalar sistemasini yechishda quyidagi *usullar* qo'llaniladi:

1) *O'rniga qo'yish usuli.*

Tenglamalarning birortasidan bir noma'lum ikkinchisi orqali ifoda qilinadi va sistemaning boshqa tenglamasiga qo'yiladi.

2) *Algebraik qo'shish usuli.* Ushbu  $\begin{cases} a_1x + b_1y = c_1, \\ a_2x + b_2y = c_2 \end{cases}$  ko'rinishdagi

sistemani yechish uchun noma'lumlardan birining koeffitsiyentlarini modullari bo'yicha tenglashtirib, sistema tenglamalarini hadlab qo'shish yoki ayirish orqali shu noma'lum yo'qotiladi.

3) *Grafik usul.* Sistema tenglamalarining grafiklari yasaladi va ularning kesishish nuqtalarining koordinatalari topiladi.

## TENGSIKLIKLAR

### 21. Sonli tengsizliklar.

$a > b$  tengsizlik  $a - b$  ayirma musbat ekanligini bildiradi.

$a < b$  tengsizlik  $a - b$  ayirma manfiy ekanligini bildiradi.

Agar  $a > b$  bo'lsa, u holda  $b < a$  bo'ladi.

*Tengsizlik*  $>$  yoki  $<$  belgilari bilan birlashtirilgan ikkita sonli yoki algebraik ifoda.

Tengsizliklarga misollar:  $4 > 7 - 5$ ;  $2a + b < a^2 + b^2$ .

Istalgan ikkita  $a$  va  $b$  son uchun quyidagi uchta munosabatdan faqat biri to'g'ri bo'ladi:  $a > b$ ,  $a = b$ ,  $a < b$ .

*Sonli tengsizliklarning asosiy xossalari:*

1) Agar  $a > b$  va  $b > c$  bo'lsa, u holda  $a > c$  bo'ladi.

2) Agar tengsizlikning ikkala qismiga ayni bir xil son qo'shilsa, yoki ayirilsa, u holda tengsizlik belgisi o'zgarmaydi: agar  $a > b$  bo'lsa, u holda istalgan  $c$  uchun  $a + c > b + c$  va  $a - c > b - c$  bo'ladi.

Istalgan sonni tengsizlikning bir qismidan ikkinchi qismiga, uning ishorasini qarama-qarshisiga o'zgartirib olib o'tish mumkin.

3) Tengsizlikning ikkala qismini nolga teng bo'lmagan songa ko'paytirish yoki bo'lish mumkin, bunda, agar bu son musbat bo'lsa, tengsizlik ishorasi o'zgarmaydi, agar bu son manfiy bo'lsa, u holda tengsizlik ishorasi qarama-qarshisiga o'zgaradi, ya'ni agar  $a > b$  bo'lsa, u holda

$$c > 0 \text{ bo'lganda } ac > bc \text{ va } \frac{a}{c} > \frac{b}{c},$$

$$c < 0 \text{ bo'lganda } ac < bc \text{ va } \frac{a}{c} < \frac{b}{c}.$$

*Tengsizliklarni qo'shish.* Bir xil ishorali tengsizliklarni qo'shish mumkin, bunda xuddi shu ishorali tengsizlik hosil bo'ladi: agar  $a > b$  va  $c > d$  bo'lsa, u holda  $a + c > b + d$  bo'ladi.

Masalan:

$$\begin{array}{r} 4 > 3,5 \\ + -2 > -5 \\ \hline 2 > -1,5 \end{array} \quad \begin{array}{r} 2,3 < 3,5 \\ + -4 < -3 \\ \hline -1,7 < 0,5 \end{array}$$

*Tengsizliklarni ko'paytirish.* Chap va o'ng qismlari musbat bo'lgan bir xil ishorali tengsizliklarni hadlab ko'paytirish mumkin, bunda xuddi shu ishorali tengsizlik hosil bo'ladi: agar  $a > b$ ,  $c > d$  va  $a, b, c, d$  musbat sonlar bo'lsa, u holda  $ac > bd$  bo'ladi.

Masalan,

$$\begin{array}{r} 2,4 > 2,1 \\ \times \\ \hline 4 > 3 \\ \hline 9,6 > 6,3 \end{array} \qquad \begin{array}{r} 1,7 < 2,3 \\ \times \\ \hline 2 < 3 \\ \hline 3,4 < 6,9 \end{array}$$

Agar  $a > b$  va  $a, b$  musbat sonlar bo'lsa, u holda  $a^2 > b^2$ ,  $a^3 > b^3$  va, umuman, istalgan natural  $n$  uchun  $a^n > b^n$  tengsizlik bajariladi. Masalan,  $6^2 > 5^2$ ,  $6^3 > 5^3$ ,  $6^{12} > 5^{12}$ .

*Qat'iy tengsizliklar*  $>$  (katta) va  $<$  (kichik) ishorali tengsizliklar. Masalan,  $5 > 3$ ,  $x < 1$ .

*Noqat'iy tengsizliklar*  $\geq$  (katta yoki teng) va  $\leq$  (kichik yoki teng) ishorali tengsizliklar. Masalan,  $a^2 + b^2 \geq 2ab$ ,  $x \leq 3$ .

$a \geq b$  noqat'iy tengsizlik  $a > b$  yoki  $a = b$  ekanligini bildiradi.

*Noqat'iy tengsizliklarni xossalari* xuddi qat'iy tengsizliklarning xossalari kabidir. Bunda qat'iy tengsizliklarning xossalarida  $>$  va  $<$  ishoralari, noqat'iy tengsizliklarning xossalarida esa  $\geq$  va  $\leq$  ishoralari *qarama-qarshi ishoralar* deyiladi.

Ikkita  $a$  va  $b$  sonning o'rta arifmetigi:  $\frac{a+b}{2}$ .

Ikkita  $a$  va  $b$  sonning o'rta geometrigi:  $\sqrt{ab}$ .

Agar  $a \geq 0$ ,  $b \geq 0$  bo'lsa, u holda  $\frac{a+b}{2} \geq \sqrt{ab}$  bo'ladi.

**22. Bir noma'lumli tengsizlik** – harf bilan belgilangan noma'lum sonni o'z ichiga olgan tengsizlik.

Bir noma'lumli birinchi darajali tengsizliklarga misollar:

$$3x + 4 < 5x - 2; \quad \frac{1}{3}x - 1 \geq \frac{3-x}{4}.$$

*Bir noma'lumli tengsizlikning yechimi* – noma'lumning berilgan tengsizlikni to'g'ri sonli tengsizlikka aylantiruvchi qiymati.

Masalan, 3 soni  $x + 1 > 2 - x$  tengsizlikning yechimi bo'ladi, chunki  $3 + 1 > 2 - 3$ .

*Tengsizlikni yechish* – uning barcha yechimlarini topish yoki ularning yo'qligini isbotlash demakdir.

*Bir noma'lumli tengsizliklarning asosiy xossalari:*

1) tengsizlikning istalgan hadini uning bir qismidan ikkinchi qismiga ishorasini qarama-qarshisiga o'zgartirgan holda olib o'tish mumkin, bunda tengsizlik ishorasi o'zgarmaydi:

2) tengsizlikning ikkala qismini nolga teng bo'lmagan ayni bir xil songa ko'paytirish yoki bo'lish mumkin: agar bu son musbat bo'lsa, tengsizlik ishorasi o'zgarmaydi, bordi-yu, bu son manfiy bo'lsa, u holda tengsizlik ishorasi qarama-qarshisiga o'zgaradi.

*Bir noma'lumli birinchi darajali tengsizliklar sistemasi* – ayni bir noma'lum sonning birinchi darajasini o'z ichiga olgan va birgalikda qaraladigan ikki yoki bir nechta tengsizliklar.

*Tengsizliklar sistemasining yechimi* – noma'lumning sistemaning hamma tengsizliklarini to'g'ri sonli tengsizlikka aylantiruvchi qiymati.

*Tengsizliklar sistemasini yechish* – uning barcha yechimlarini topish yoki ularning yo'qligini isbotlash demakdir.

## FUNKSIYALAR VA GRAFIKLAR

**23. Funksiya.** Agar biror sonlar to'plamidan olingan har bir  $x$  songa  $y$  son mos qo'yilgan bo'lsa, u holda shu to'plamda  $y(x)$  funksiya berilgan deyiladi. Bunda  $x$  ni *erkli o'zgaruvchi* (yoki *argument*),  $y$  ni esa *erksiz o'zgaruvchi* deyiladi.

*Funksiyaning aniqlanish sohasi* – uning argumenti qabul qilishi mumkin bo'lgan barcha qiymatlar to'plami.

Agar funksiya formula bilan berilgan bo'lsa, u holda uning aniqlanish sohasi – argumentning shu formula ma'noga ega bo'ladigan qiymatlari to'plami bo'ladi.

Masalan,  $y = \sqrt{x-2}$  funksiya  $x \geq 2$  bo'lganda aniqlangan.

Agar biror oraliqda argumentning katta qiymatiga funksiyaning katta qiymati mos kelsa,  $y(x)$  funksiya shu oraliqda o'suvchi deyiladi, ya'ni shu oraliqqa tegishli ixtiyoriy  $x_1, x_2$  uchun  $x_2 > x_1$  bo'lsa, u holda  $y(x_2) > y(x_1)$  bo'ladi. Masalan,  $y = x^3$  funksiya son o'qi  $R$  da o'sadi.  $y = x^2$  funksiya  $x > 0$  oraliqda o'sadi.

Agar biror oraliqda argumentning katta qiymatiga funksiyaning kichik qiymati mos kelsa, u holda  $y(x)$  funksiya shu oraliqda kamayuvchi deyiladi, ya'ni shu oraliqqa tegishli bo'lgan istalgan  $x_1, x_2$  uchun  $x_2 > x_1$  bo'lsa, u holda  $y(x_2) < y(x_1)$  bo'ldi. Masalan,  $y = -2x$  funksiya son o'qi  $R$  da kamayuvchi bo'ladi;  $y = x^2$  funksiya  $x \leq 0$  oraliqda kamayadi;

$y = \frac{1}{x}$  funksiya barcha  $x \neq 0$  da kamayadi.

*$y(x)$  funksiyaning grafigi* – koordinatalar tekisligining  $(x; y(x))$  koordinatali barcha nuqtalari to'plami.

*Juft funksiya* – uning aniqlanish sohasidan olingan har bir  $x$  uchun  $y(-x) = y(x)$  xossaga ega bo'lgan  $y(x)$  funksiya. Masalan,  $y = x^4$  juft funksiya. *Juft funksiyaning grafigi ordinatalar o'qiga nisbatan simmetrik.*

*Toq funksiya* – uning aniqlanish sohasidan olingan har bir  $x$  uchun  $y(-x) = -y(x)$  xossaga ega bo'lgan  $y(x)$  funksiya.

Masalan,  $y = x^3$  – toq funksiya.

*Toq funksiyaning grafigi koordinatalar boshiga nisbatan simmetrik.*

**24. Chiziqli funksiya** –  $y = kx + b$  ko'rinishdagi funksiya, bunda  $k$  va  $b$  – berilgan sonlar.

$y = kx + b$  chiziqli funksiyaning grafigi – to'g'ri chiziq,  $b = 0$  bo'lganda funksiya  $y = kx$  ko'rinishni oladi, uning grafigi koordinatalar boshidan o'tadi.

**25. To'g'ri proporsional bog'lanish** –  $y = kx$  formula bilan ifodalanagan bog'lanish, bunda  $k > 0$ ,  $x > 0$ .

**26. Teskari proporsional bog'lanish**, bu  $y = \frac{k}{x}$  formula bilan ifodalanagan bog'lanish, bunda  $k > 0$ ,  $x > 0$ ,  $k$  – proporsionallik koeffitsiyenti.

$y = \frac{k}{x}$  ( $k \neq 0$ ) funksiya  $x \neq 0$  bo'lganda aniqlangan, noldan boshqa barcha haqiqiy qiymatlarni qabul qiladi.

Agar  $k > 0$  bo'lsa, u holda  $y = \frac{k}{x}$  funksiya (masalan,  $y = \frac{2}{x}$ ,  $y = \frac{1}{2x}$ ):

a)  $x > 0$  bo'lganda musbat qiymatlarni,  $x < 0$  bo'lganda manfiy qiymatlarni qabul qiladi:

b)  $x < 0$  va  $x > 0$  oraliqlarda kamayadi.

Agar  $k < 0$  bo'lsa,  $y = -\frac{k}{x}$  funksiya (masalan,  $y = -\frac{1}{x}$ ,  $y = -\frac{2}{x}$ ,  $y = -\frac{1}{3x}$ );

a)  $x < 0$  bo'lganda musbat qiymatlarni va  $x > 0$  bo'lganda manfiy qiymatlarni qabul qiladi;

b)  $x < 0$  va  $x > 0$  oraliqlarda o'sadi.

$y = \frac{k}{x}$  funksiyaning grafigi *giperbola* deyiladi. U koordinatalar boshiga nisbatan simmetrik joylashgan ikkita tarmoqqa ega.  $k > 0$  bo'lganda grafik birinchi va uchinchi choraklarda,  $k < 0$  bo'lganda esa ikkinchi va to'rtinchi choraklarda joylashadi.



## JAVOBLAR

2. 2)  $x_1=0, x_2=1$ ; 4)  $x$  ning berilgan funksiyaning qiymati  $-5$  ga teng bo'ladigan haqiqiy qiymatlari yo'q. 3. 2)  $x_1=1\frac{3}{4}, x_2=-1$ ; 4)  $x_1=0, x_2=\frac{3}{4}$ . 4. 2) 0; 4) 1.
5. 2) nollari yo'q; 4)  $x_1=\frac{2}{3}, x_2=\frac{1}{2}$ ; 6) nollari yo'q; 8)  $x=1$ . 6. 2)  $p=3, q=-$
- 4; 4)  $p=-2, q=-15$ . 7.  $x_{1,2}=\pm 2$ . 9. B va C. 12. 2)  $(\sqrt{5}; 5), (-\sqrt{5}; 5)$ ; 4) (0; 0), (2; 4); 6) (1; 1). 13. 2) Ha. 14. 2) Ha; 4) yo'q; 16. 1)  $x < -3, x > 3$ ; 2)  $-5 \leq x \leq 5$ ; 3)  $x \leq -4, x \geq 4$ ; 4)  $-6 < x < 6$ . 20. 2)  $(-3; -4,5), (2; -2)$ . 21. 2) Ha; 4) yo'q. 22. 1) O'suvchi; 2) kamayuvchi; 3) o'suvchi; 4) o'suvchi ham, kamayuvchi ham bo'lmaydi. 23. 3 m/s<sup>2</sup>. 26. 2) (0; -5); 4)  $(\frac{1}{8}; \frac{1}{16})$ ; 6) (0,5; 0). 27. 2)  $x=-2$ ; 4)  $x=2$ ; 6)  $x=\frac{3}{4}$ . 28. 2) Yo'q; 4) yo'q. 29. 2) (1; 0), (0,5; 0), (0; -1); 4) (0; 0),  $(\frac{4}{3}; 0)$ . 30.  $y=x^2-2x+3$ . 32. 2)  $k=-10$ . 34. 1)  $y=2(x-3)^2$ ; 2)  $y=2x^2+4$ ; 3)  $y=2(x+2)^2-1$ ; 4)  $y=2(x-1,5)^2+3,5$ . 35. 2)  $(-\frac{3}{2}; \frac{11}{4})$ ; 4)  $(\frac{5}{2}; \frac{21}{4})$ .
36. 2) (1; 0), (-5; 0), (0; 10); 4) (0; 14). 40. 7,5+7,5. 41. 5 va 5. 42. Devorga parallel tomon 6 m; qolgan tomonlari 3 m dan. 43. Yo'q. 44. 2)  $x=1$  da  $y=-5$  eng kichik quymat; 4)  $x=1$  da  $y=-2$  eng kichik qiymat. 45. 1)  $a > 0, b > 0, c > 0$ ; 2)  $a < 0, b > 0, c < 0$ . 46. 1) 5 s dan keyin eng katta balandlik 130 m ga teng; 2)  $(5+\sqrt{26})s$ . 47. 2)  $x_1=2, x_2=0,5$ ; 4)  $x$  ning bunday qiymati yo'q. 48. 2) (1; 1), (2; 4); 4) (-5; 18). 49. 2)  $x < -6, x > 6$ . 50. 2) (5; 0), (-2; 0), (0; 10); 4) (1; 0),  $(-\frac{11}{7}; 0)$ , (0; -11). 51. 2) (-1; 4); 4)  $(-\frac{1}{2}; 1)$ ; 6)  $(-\frac{1}{2}; -6\frac{1}{4})$ . 53. 2) Eng katta qiymat 4 ga teng; 4) eng kichik qiymat  $3\frac{2}{3}$  ga teng. 54. 150 m va 150 m. 55. 200 m va 400 m. 56. 2)  $p=1, q=0$ . 57. 2)  $p=-4, q=3$ . 58. 1)  $x_1=1, x_2=-5$ ; 2)  $x_1=0, x_2=1, x_3=2$ . 59. 1)  $a=1, b=-2, c=0$ ; 2)  $a=1, b=-2, c=4$ ; 3)  $a=-2, b=8, c=-6$ . 61. 2)  $3x^2-x-1 > 0$ ; 4)  $2x^2+x-5 < 0$ . 63. 2)  $3 < x < 11$ ; 4)  $x < -7, x > -1$ . 64. 2)  $x < -3, x > 3$ ; 4)  $x < 0, x > 2$ . 65. 2)  $-2 < x < 1$ ; 3)  $x < -3, x > 1$ ; 6)  $x < -1, x > \frac{1}{3}$ .
66. 2)  $x > \frac{1}{6}$ ; 4)  $x < -4, x > 2$ . 69. Musbat qiymatlar  $x < -3, x > 2$  oraliqlarda,

- manfiy qiymatlar  $-3 < x < 2$  intervalda. **71.** 2)  $x \leq -1, x \geq 4$ ; 4)  $-1 < x < 4$ .
- 72.** 2)  $x < -\frac{1}{3}, x > 2$ ; 4)  $x \leq -0,25; x \geq 1$ . **73.** 2)  $x = 7$ ; 4) yechimlari yo'q; 6)  $x$  - istalgan haqiqiy son. **74.** 2) Yechimlari yo'q; 4) yechimlari yo'q; 6)  $x$  - istalgan haqiqiy son. **75.** 2)  $x < -\sqrt{7}, x > \sqrt{7}$ ; 4)  $x < -2; x > 0$ ; 6)  $x < -5; x > 3$ ; 8)  $-2 < x < 1$ . **77.** 2)  $x < -\frac{5}{3}, x > \frac{5}{3}$ ; 4)  $-1 < x < 4$ ; 6)  $x$  - istalgan haqiqiy son; 8)  $x = -3$ . **78.** 2)  $x$  - istalgan haqiqiy son; 4)  $x \neq \frac{1}{4}$ ; 6)  $-\frac{1}{3} \leq x \leq 0$ ; 8) yechimlari yo'q. **79.** 2) Yechimlari yo'q; 4)  $-0,5 < x < 3$ ; 6)  $x$  - istalgan haqiqiy son. **80.** 2)  $x = 1$ ; 4)  $x$  - istalgan haqiqiy son. **82.**  $-6 < r < 2$ . **84.** 2)  $-5 < x < 8$ ; 4)  $x < -5, x > 3\frac{1}{2}$ . **85.** 2)  $x < 0, x > 9$ ; 4)  $-3 < x < 0$ ; 6)  $x < -1, x > 3$ .
- 86.** 2)  $-\frac{1}{2} < x < 0, x > \frac{1}{2}$ ; 4)  $-2 < x < 2, x > 5$ . **87.** 2)  $-7 < x < 7$ ; 4)  $-4 < x < 4, x > 4$ ; 6)  $x = -2; 2 \leq x \leq 5$ . **88.** 2)  $-3 < x < 4$ ; 4)  $-3,5 \leq x < 7$ ; 6)  $-2 \leq x < -1, x \geq 3$ . **89.** 2)  $x < 0,5, x > 1$ ; 4)  $x < -\frac{2}{3}, 0 < x < \frac{1}{2}, x > \frac{2}{3}$ . **90.** 2)  $-4 < x < -2, x > 3$ ; 4)  $-3 \leq x \leq -1, 4 \leq x \leq 5$ . **91.** 2)  $x < -2, 2 < x < 6$ ; 4)  $x < -3, -1 \leq x < 2, x \geq 4$ . **92.** 2)  $-\sqrt{15} < x < -3, 0 < x < \sqrt{15}$ . **93.** 1)  $-8 < x < -1$ ; 2)  $x < -5, x > 2$ ; 3)  $-1 < x \leq -\frac{2}{5}$ ; 4)  $x < -4, -4 < x < \frac{3}{2}, x > 4$ . **94.** 2)  $x < 2, x > 4$ ; 4)  $x < 3, x > 4$ .
- 95.** 2)  $x < -6, x > 6$ ; 4)  $-\frac{3}{4} \leq x \leq \frac{3}{4}$ . **96.** 2)  $-\frac{1}{2} \leq x \leq \frac{1}{2}$ ; 4)  $x \leq 0$ . **97.** 2)  $x < \frac{1}{2}, x > 4$ ; 4)  $-2 < x < \frac{1}{2}$ ; 6)  $x < \frac{4}{5}, x > 1$ . **98.** 2)  $x \neq -5$ ; 2)  $x \neq -\frac{3}{2}$ ; 6)  $x \neq \frac{1}{2}$ . **99.** 2) Yechimlari yo'q; 4) yechimlari yo'q; 6) yechimlari yo'q. **100.** 2)  $x < -1, 1 < x < 4$ ; 4)  $x < -\frac{1}{2}, 4 < x \leq 7$ ; 6)  $x < -\frac{1}{2}, 1 < x < 2$ . **101.** 2)  $-1 < x < 5$ ; 4)  $-5 \leq x \leq 2$ ; 6)  $x \leq -\frac{1}{3}, x \geq \frac{1}{3}$ . **102.** 2)  $x$  - istalgan haqiqiy son; 4) yechimlari yo'q; 6)  $\frac{1}{2} < x < 1$ ; 8)  $x$  - istalgan haqiqiy son. **103.** 2)  $x \leq \frac{1}{2}, x \geq 3$ ; 4)  $x = \frac{2}{3}$ ; 6) yechimlari yo'q. **104.** 2)  $x < -\sqrt{3}; -\frac{\sqrt{3}}{2} < x < \sqrt{3}$ ; 4)  $x < -4, -1 < x \leq 1, x > 1$ . **105.** 2)  $-1 < x < -\frac{1}{3}, \frac{3}{4} < x < 2$ ; 4)  $-\frac{1}{3} < x \leq -\frac{1}{5}, -1 < x \leq 2$ . **106.** 12 km/soatdan kam emas. **108.** 2)  $x < -3, -2 < x < 1, x \geq 3$ ; 2)  $-3 < x < -2, -1 \leq x \leq 1$ ; 3)  $-\sqrt{2} < x < -1, 1 < x < \sqrt{2}$ ; 4)  $x < -2, -\sqrt{3} < x < -3, x > 2$ . **109.** 2) 32; 4) 0. **110.** 2)  $\left(\frac{1}{5}\right)^a$ ; 4)  $\left(\frac{c}{d}\right)^b$ . **112.** 2)  $21^{-3}$ ; 4)  $a^{-9}$ . **113.** 2)  $\frac{121}{81}$ ;

- 4) 32; 6)  $-\frac{1}{169}$ . 114. 2)  $\frac{53}{16}$ ; 4) -875. 116. 2)  $\frac{1}{(x+y)^3}$ ; 4)  $\frac{9a^3}{b^4}$ ; 6)  $\frac{a^2}{bc^4}$ . 117. 2) -125;
- 4)  $\frac{1}{17}$ . 118. 2) 0,0016; 4)  $\frac{16}{625}$ . 119. 2)  $b^8$ ; 4)  $b^{-28}$ . 120. 2)  $a^8b^{-4}$ ; 4)  $3^{-4}a^{-12}$ ;
121. 2)  $m^{12}n^{-15}$ ; 4)  $-64x^{-15}y^3z^{-9}$ . 122. 2)  $-\frac{97}{9}$ . 123. 2)  $2,7 \cdot 10^{-8}$ ; 4)  $8 \cdot 10^{-9}$ .
124. 2)  $5,086 \cdot 10^{-8}$ ; 4)  $1,6 \cdot 10^{-3}$ . 125. 0,003. 126.  $10^{-11}$ . 127. 0,0001 mm.
128. 2)  $a^5$ ,  $\frac{1}{32}$ . 129. 2) 0. 130. 2)  $b - a$ . 132. 2) 2; 4) 15. 133. 2) 81; 4)  $\frac{1}{81}$ .
134. 2) -1; 4) -4; 6) -8. 135. 2)  $x = -\frac{1}{2}$ ; 4)  $x_1 = -2$ ,  $x_2 = 2$ . 136. 2)  $x$  - istalغان son; 4)  $\frac{2}{3} \leq x < 2$ . 137. 2) 5; 4) -11; 6)  $\frac{1}{30}$ . 138. 2) 2; 4)  $4\sqrt{6}$ . 139. 1)  $x-2$ ;
- 2)  $(3-x)^3$ ,  $x \leq 3$  da,  $(x-3)^3$ ,  $x > 3$  da. 140. 3974. 664. 2)  $36\sqrt[3]{4}$ ; 4) 20.
142. 2) 33; 4) 7. 143. 2) 0,2; 4) 2. 144. 2) 50; 4) 16. 145. 2)  $a^2b^3$ ; 4)  $a^2b^3$ .
146. 2)  $3ab$ ; 4)  $\frac{2}{b}$ . 147. 2)  $\frac{2}{3}$ ; 4)  $\frac{3}{2}$ . 148. 2)  $\frac{2}{5}$ ; 4) 2; 6) 4. 149. 2)  $3x$ ; 4)  $2\frac{b}{a}$ .
150. 2)  $\frac{1}{3}$ ; 4)  $\frac{1}{4}$ . 151. 2)  $4\sqrt[3]{4}$ ; 4) 5. 152. 2)  $y^2$ ; 4)  $a^8b^9$ ; 6)  $3a$ . 153. 2)  $\frac{3}{2}$ ;
- 4)  $\frac{3}{2}$ ; 6) 4. 154. 2)  $\frac{2a^2}{b}$ ; 4)  $\frac{a}{b}$ ; 6)  $a^2b$ . 155. 2) 6; 4)  $\frac{1}{2}$ ; 6) 4. 156. 2)  $ab^2c$ ; 4)  $2xy$ .
157. 2)  $3x$ ; 4) 0. 158. 2) 7; 4) 1. 162. 2) 3; 4) 27; 6)  $\frac{1}{27}$ . 163. 2) 5; 4)  $\frac{1}{2}$ ;
- 6)  $\frac{1}{2}$ . 164. 2) 49; 4) 125. 165. 2) 121; 4) 150. 166. 2) 3; 4) 2,7. 167. 2)  $b$ ;
- 4)  $a$ ; 6) 1. 168. 2)  $a^2b$ . 169. 2) 1. 170. 2) 3. 171. 2)  $b^2$ ; 4)  $a+b$ ; 6)  $a^{\frac{1}{4}} + b^{\frac{1}{4}}$ ;
- 8)  $\sqrt{c} - 1$ . 172. 2)  $\frac{a^{\frac{1}{3}} \cdot b^{\frac{1}{3}}}{a^{\frac{1}{3}+b^{\frac{1}{3}}}}$ ; 4)  $2\sqrt{b}$ . 173. 2)  $2y$ ; 4)  $2\sqrt[3]{b}$ . 174. 2)  $2\sqrt[3]{b}$ ; 4)  $\frac{2\sqrt[3]{a}}{a+b}$ .
176. 2)  $\left(\frac{5}{12}\right)^{\frac{1}{4}} < (0,41)^{\frac{1}{4}}$ ; 4)  $\left(\frac{11}{12}\right)^{-\sqrt{5}} > \left(\frac{12}{13}\right)^{-\sqrt{5}}$ . 177. 2)  $x = 3$ ; 4)  $x = 2$ ; 6)  $x = \frac{1}{2}$ .
178.  $\sqrt{\left(1\frac{1}{4}-1\frac{1}{5}\right)^3} > \sqrt{\left(1\frac{1}{6}-1\frac{1}{7}\right)^3}$ . 179. 2)  $x = \frac{5}{2}$ ; 4)  $y = 5$ . 180. 2)  $x = 2,6$ ; 4)  $x = 4$ .
181. 2)  $x = -\frac{1}{3}$ ; 4)  $x = 1$ . 182. 2) 6; 4) -3. 183. 2) -3; 4)  $\frac{1}{16}$ . 184. 2) 51;
- 4) 0,04; 6) -0,1. 185. 2) 1000. 186. 2)  $\sqrt[4]{x}$ ; 4)  $\frac{1}{\sqrt{x^2-y^2}}$ . 187. 2)  $x = -1$ ; 4)  $x = 1$ .

188. 2)  $\frac{95}{16}$ ; 4)  $-609\frac{8}{27}$ . 189. 2)  $x$  - istalgan son; 4)  $x \leq 2$ ,  $x \geq 3$ ; 6)  $0 \leq x \leq 2$ ,  $x \geq 3$ .
190. 2)  $a+1$ ; 4)  $a^{\frac{1}{3}} + b^{\frac{1}{3}}$ ; 6)  $a^{\frac{1}{2}} - b^{\frac{1}{2}}$ . 191. 2)  $x = 2$  da  $y = 1$ ;  $x = 0$  va  $x = 4$  da  $y = 5$ ;  $x = -1$  va  $x = 5$  da  $y = 10$ ;  $x = -2$  va  $x = 6$  da  $y = 17$ . 192. 1)  $y(-2) = -1$ ,  $y(0) = -5$ ,  $y(\frac{1}{2}) = -11$ ,  $y(3) = 4$ ; 2)  $x = -\frac{1}{2}$  da  $y = -3$ ;  $x = -1$  da  $y = -2$ ;  $x = \frac{3}{2}$  da  $y = 13$ ;  $x = \frac{4}{3}$  da  $y = 19$ . 194. 2)  $x \leq 2$ ,  $x \geq 5$ ; 4)  $-2 \leq x < 3$ . 195. 1)  $y(-3) = 3$ ,  $y(-1) = 1$ ,  $y(1) = -1$ ,  $y(3) = -1$ ; 2)  $x = 2$  da  $y = -2$ ;  $x = 0$  va  $x = 4$  da  $y = 0$ ;  $x = -2$  va  $x = 6$  da  $y = 2$ ;  $x = -4$  va  $x = 8$  da  $y = 4$ . 196. 2)  $x \neq -1$ ; 4)  $-1 \leq x \leq 1$ ,  $x \geq 4$ ; 6)  $-5 \leq x \leq 1$ ,  $x > 2$ ; 8)  $x \geq 0$ .
197. 2) ha; 4) Ha. 203. 2)  $x = 16$ ; 4)  $x = \frac{1}{16}$ ; 6)  $x = \frac{1}{243}$ . 205. 2)  $x = 32$ ; 4)  $x = 8$ .
208. 2) toq; 4) juft ham, toq ham bo'lmaydi. 209. 2) toq; 4) toq; 6) juft ham, toq ham bo'lmaydi. 218. 2)  $x = 0$ . 219. 2)  $(-1; 0)$ . 220. 2)  $x = -4$  da  $y = -\frac{1}{2}$ ; 4)  $x < 0$  va  $x \geq 2$  da  $y \leq 1$ . 222. 2)  $(-2; 4)$  va  $(2; -4)$ ; 4)  $(-4; -2)$  va  $(1; 3)$ . 228. 2)  $x \leq 3$ ; 4)  $y < 5$ ; 6)  $x < -5$ ,  $x > 5$ . 229. Kubning qirrasi 7 dm dan ortiq. 232. 2)  $x = 10$ ; 4)  $x = 5$ . 233. 2)  $x = 2$ ; 4)  $x = 2$ ;  $x = -7$ . 234. 2)  $x = 4$ ; 4)  $x = 0,2$ . 235.  $x = \frac{7}{3}$ .
236. 2)  $x > -3$ ; 4)  $x < 2$ ; 6)  $x < 1$ ,  $x > 7$ . 238. 2)  $x = -2$ ; 4)  $x_1 = 1$ ;  $x_2 = 3$ . 239. 2)  $x = 2,25$ . 240. 2)  $x = 1$ ; 4)  $x = 5$ . 241. 2)  $x = 4$ . 242. 2)  $2 \leq x \leq 3$ ; 4)  $1 < x \leq 2$ ; 6)  $x \geq 1$ .
243. 2)  $x \neq \frac{3}{2}$ ; 4)  $x$  - istalgan son. 248. 2)  $(-\frac{1}{\sqrt{2}}; -\sqrt{2})$ ,  $(-\frac{1}{\sqrt{2}}; \sqrt{2})$ ; 4)  $(-1; -1)$ ;  $(1; 1)$ . 249. 2)  $x > 2$ ; 4)  $x \leq -2$ . 250. 2)  $x = 16$ ; 4)  $x_1 = \frac{1}{2}$ ,  $x_2 = \frac{1}{3}$ ; 6)  $x = -1$ .
251. 2)  $x$  - istalgan son; 4)  $2 \leq x \leq 11$ ; 6)  $x < -7$ ,  $-3 \leq x < -1$ ,  $x \geq 3$ . 252. 2) kamayadi; 4) kamayadi. 253. 2) toq; 4) juft ham, toq ham bo'lmaydi. 255. 2)  $-2 \leq x \leq \frac{1}{3}$ . 256. 2)  $x_1 = -1$ ,  $x_2 = 7$ ; 4)  $x = 81$ ; 6)  $x_1 = 3$ ,  $x_2 = 7$ . 257. 1)  $x < -1$ ,  $x > 9$ ; 2)  $-1 < x \leq 0$ ,  $3 \leq x < 4$ ; 3)  $\frac{2}{3} \leq x < 6$ ; 4)  $x \geq 4$ . 258. 2)  $\frac{2\pi}{3}$ ; 4)  $\frac{5\pi}{6}$ ; 6)  $\frac{8\pi}{45}$ ; 8)  $\frac{7\pi}{9}$ . 259. 2)  $20^\circ$ ; 4)  $135^\circ$ ; 6)  $(\frac{720}{\pi})^\circ$ ; 8)  $(\frac{324}{5\pi})^\circ$ . 260. 2) 4,71; 4) 2,09.
261. 2)  $2\pi < 6,7$ ; 4)  $\frac{3\pi}{2} < 4,8$ ; 6)  $-\frac{3\pi}{2} < -\sqrt{10}$ . 263. 0,4 m. 264. 2 rad. 265.  $\frac{3\pi}{8}$  sm<sup>2</sup>. 266. 2 rad. 267. 2)  $(-1; 0)$ ; 4)  $(0; -1)$ ; 6)  $(1; 0)$ . 269. 2) ikkinchi chorak; 4) to'rtinchi chorak; 6) ikkinchi chorak. 270. 2)  $(0; 1)$ ; 4)  $(-1; 0)$ ; 6)  $(0; 1)$ .
271. 2)  $2\pi k$ ,  $k = 0, \pm 1, \pm 2, \dots$ ; 4)  $\frac{\pi}{2} + 2\pi k$ ,  $k = 0, \pm 1, \pm 2, \dots$ . 272. 2) ikkinchi chorak; 4) to'rtinchi chorak. 273. 2)  $x = 1,8\pi$ ,  $k = 4$ ; 4)  $x = \frac{4}{3}\pi$ ,  $k = 3$ ; 6)  $x = \frac{5}{3}\pi$ ,

$k = 2$ . 275. 2)  $(0; 1)$ ; 4)  $(0; -1)$ . 276. 2)  $\frac{\pi}{6} + 2\pi k$ ,  $k = 0, \pm 1, \pm 2, \dots$ ; 4)  $\frac{3\pi}{4} + 2\pi k$ ,  
 $k = 0, \pm 1, \pm 2, \dots$ . 277. 2)  $-\frac{1}{2}$ ; 4)  $-1$ ; 6)  $-1$ ; 8)  $\frac{1}{\sqrt{2}}$ . 279. 2)  $-1$ ; 4)  $-1$ ; 6)  $1$ .  
280. 2)  $0$ ; 4)  $-1$ . 281. 2)  $\frac{-\sqrt{2}-9}{2}$ ; 4)  $-\frac{1}{4}$ . 282. 2)  $x = \frac{\pi}{2} + \pi k$ ,  $k = 0, \pm 1, \pm 2, \dots$ ;  
4)  $x = \frac{\pi}{2} + 2\pi k$ ,  $k = 0, \pm 1, \pm 2, \dots$ . 284. 2)  $-\frac{5}{4}$ ; 4)  $\frac{1+\sqrt{2}}{2}$ . 285. 2)  $x = \pi + 2\pi k$ ,  $k = 0,$   
 $\pm 1, \pm 2, \dots$ ; 4)  $x = \pi + 2\pi k$ ,  $k = 0, \pm 1, \pm 2, \dots$ ; 6)  $x = \frac{2}{3}k\pi$ ,  $k = 0, \pm 1, \pm 2, \dots$ .  
286. 2)  $x = 2\pi k - 1$ ,  $k = 0, \pm 1, \pm 2, \dots$ ; 4)  $x = k\pi - 1$ ,  $k = 0, \pm 1, \pm 2, \dots$ ; 6)  $x = \frac{2\pi k}{3} + 1$ ,  
 $k = 0, \pm 1, \pm 2, \dots$ . 287. 2) ikkinchi chorak; 4) ikkinchi chorak; 6) ikkinchi chorak.  
288. 2) musbat; 4) musbat; 6) musbat. 289. 2) manfiy; 4) manfiy; 6) musbat.  
290. 2) musbat, musbat; 4) manfiy, manfiy; 6) manfiy, manfiy; 8) musbat,  
musbat. 291. 2)  $\sin\alpha < 0$ ,  $\cos\alpha > 0$ ,  $\operatorname{tg}\alpha < 0$ ,  $\operatorname{ctg}\alpha < 0$ ; 4)  $\sin\alpha > 0$ ,  $\cos\alpha > 0$ ,  $\operatorname{tg}\alpha > 0$ ,  
 $\operatorname{ctg}\alpha > 0$ . 292. 2)  $\sin 3 > 0$ ,  $\cos 3 < 0$ ,  $\operatorname{tg} 3 < 0$ ; 4)  $\sin(-1,3) < 0$ ,  $\cos(-1,3) > 0$ ,  $\operatorname{tg}(-1,3) < 0$ .  
293. 2) manfiy; 4) musbat; 6) musbat; 8) manfiy. 294. Agar  $0 < \alpha < \frac{\pi}{2}$   
yoki  $\pi < \alpha < \frac{3\pi}{2}$  bo'lsa,  $\sin\alpha$  va  $\cos\alpha$  sonlarining ishoralari mos tushadi;  
agar  $\frac{\pi}{2} < \alpha < \pi$  yoki  $\frac{3\pi}{2} < \alpha < 2\pi$  bo'lsa,  $\sin\alpha$  va  $\cos\alpha$  sonlari qarama-qarshi  
ishoralarga ega. 295. 2) manfiy; 4) musbat. 296. 2)  $\cos 1,3 > \cos 2,3$ ; 297. 2)  $x = \frac{\pi}{2} + k\pi$ ,  
 $k = 0, \pm 1, \pm 2, \dots$ ; 4)  $x = \pi + 2k\pi$ ,  $k = 0, \pm 1, \pm 2, \dots$ . 298. 2) ikkinchisi chorak. 299.  $\frac{k \cos \alpha}{1 - \cos \alpha}$ .  
300. 2)  $\cos \alpha = -\frac{3}{5}$ ,  $\operatorname{tg} \alpha = -\frac{4}{3}$ ; 4)  $\cos \alpha = -\frac{\sqrt{21}}{5}$ ,  $\operatorname{tg} \alpha = \frac{2}{\sqrt{21}}$ ,  $\operatorname{ctg} \alpha = \frac{\sqrt{21}}{2}$ ;  
6)  $\sin \alpha = -\frac{1}{\sqrt{10}}$ ,  $\cos \alpha = \frac{3}{\sqrt{10}}$ . 301. 2) bajariladi; 4) bajarilmaydi.  
302. 2) bajarilmaydi. 303.  $\cos \alpha = \frac{9}{11}$ ,  $\operatorname{tg} \alpha = \frac{2\sqrt{10}}{9}$ . 304.  $\frac{1}{3}$ . 305.  $\cos \alpha = \pm \frac{3}{4}$ .  
306.  $\sin \alpha = \pm \frac{2}{\sqrt{5}}$ . 307. 2)  $\frac{1}{3}$ ; 4) 2. 308. 1)  $-\frac{3}{8}$ ; 2)  $\frac{11}{16}$ . 309. 1)  $x = \pi k$ ,  $k = 0, \pm 1,$   
 $\pm 2, \dots$ ; 2)  $x = -\frac{\pi}{2} + 2\pi k$ ,  $k = 0, \pm 1, \pm 2, \dots$ ; 3)  $x = 2\pi k$ ,  $k = 0, \pm 1, \pm 2, \dots$ ; 4)  $\frac{\pi}{2} + \pi k$ ,  
 $k = 0, \pm 1, \pm 2, \dots$ . 311. 1) 0; 4)  $1 + \sin \alpha$ . 312. 2) 3; 4) 4. 316. 2)  $\frac{2}{\sqrt{3}}$ . 317.  $\frac{8}{25}$ .  
318.  $\frac{37}{125}$ . 319. 1)  $x = \pi k$ ,  $k = 0, \pm 1, \pm 2, \dots$ ; 2)  $x = \frac{\pi}{2} + 2\pi k$ ,  $k = 0, \pm 1, \pm 2, \dots$ .  
320. 2)  $\frac{1}{3}$ ; 4)  $-3$ . 321. 2)  $2\cos \alpha$ ; 4) 2. 323. 2) 2. 324. 2)  $-2\cos \alpha$ . 325. 2)  $-\frac{1}{2}$ ;  
4)  $-\frac{1}{2}$ . 326. 2)  $\frac{1}{\sqrt{2}}$ ; 4)  $-1$ . 327. 2)  $\frac{4-\sqrt{2}}{6}$ . 328. 2)  $\cos 3\beta$ ; 4)  $-1$ . 329.  $-\sin \alpha \cdot \sin \beta$ .  
330. 2)  $\frac{\sqrt{3}}{2}$ ; 4) 1. 331. 2)  $-\frac{2+\sqrt{14}}{6}$ . 332. 2)  $-\sin \alpha \cdot \cos \beta$ ; 4)  $\sin \alpha \cdot \cos \beta$ .

- 333.**  $\cos(\alpha + \beta) = \frac{84}{85}$ ;  $\cos(\alpha - \beta) = \frac{36}{85}$ . **334.**  $-\frac{63}{65}$ . **335.** 2) 0; 4)  $\operatorname{tg}\alpha \cdot \operatorname{tg}\beta$ .  
**338.** 2)  $\frac{\sqrt{3}}{2}$ ; 4)  $\frac{3}{2}$ . **339.** 2)  $\frac{1}{\sqrt{2}}$ ; 4)  $-1$ . **340.** 2)  $\frac{24}{25}$ . **341.** 2)  $\frac{7}{25}$ . **342.** 2)  $\frac{1}{2} \sin 2\alpha$ ;  
4) 1. **343.** 2)  $2 \operatorname{ctg}\alpha$ ; 4)  $\operatorname{ctg}^2\alpha$ . **345.** 2)  $\frac{8}{9}$ . **347.** 2)  $\frac{1}{\sqrt{2}}$ ; 4)  $\frac{\sqrt{3}}{2}$ . **348.** 2)  $\cos 6\alpha$ ;  
4)  $\frac{1}{2 \sin \alpha}$ . **350.**  $\frac{15}{8}$ . **351.** 2)  $\sqrt{3}$ . **352.** 2) 0; 4) 0; 6)  $-1$ . **353.** 2)  $\frac{1}{\sqrt{3}}$ ; 4)  $\frac{1}{\sqrt{3}}$ ;  
6)  $-\frac{1}{\sqrt{3}}$ . **354.** 2)  $\frac{1}{\sqrt{2}}$ ; 4)  $-\frac{1}{\sqrt{2}}$ . **355.** 2)  $-\frac{1}{2}$ ; 4)  $\frac{1}{2}$ ; 6)  $\sqrt{3}$ . **356.** 2)  $-\sqrt{2}$ ; 4)  $-1$ .  
**357.** 2)  $\cos 2\alpha$ . **358.** 2)  $-\frac{5\sqrt{3}}{6}$ ; 4)  $\frac{1}{2}$ ; 6)  $\frac{5-3\sqrt{3}}{4}$ . **359.** 2) 1; 4)  $-\frac{1}{\cos \alpha}$ .  
**362.**  $x = \frac{\pi}{2} + 2\pi k$ ,  $k=0, \pm 1, \pm 2, \dots$ ; 4)  $x = \pi + 2\pi k$ ,  $k=0, \pm 1, \pm 2, \dots$ . **363.** 2)  $\sqrt{2} \sin \beta$ ;  
4)  $\sin 2\alpha$ . **364.** 2) 0; 4)  $-\frac{\sqrt{6}}{2}$ ; 6)  $\frac{\sqrt{6}}{2}$ . **365.** 2)  $4 \sin\left(\frac{\pi}{12} - \frac{\alpha}{2}\right) \cos\left(\frac{\pi}{12} + \frac{\alpha}{2}\right)$ ;  
4)  $2 \sin\left(\frac{\pi}{4} + \frac{\alpha}{2}\right) \cos\left(\frac{\pi}{4} - \frac{\alpha}{2}\right)$ . **367.** 2)  $2 \sin \alpha$ . **370.** 2)  $2\sqrt{3} \sin \frac{5\pi}{24} \sin \frac{\pi}{8}$ . **371.** 2) 0.  
**372.** 2)  $2 \cos \alpha (\cos \alpha - 1)$ ; 4)  $(\sin \alpha + \cos \alpha) \cdot \left(1 + \frac{1}{\cos \alpha}\right)$ . **373.** 2) uchinchi chorak;  
4) ikkinchi chorak; 6) ikkinchi chorak. **374.** 2) 0; 1; 4) 1; 0; 6) 0;  $-1$ . **375.** 2) 2;  
4)  $-1$ . **376.** 2)  $\frac{2}{\sqrt{5}}$ ; 4)  $-\frac{1}{\sqrt{3}}$ . **378.** 2) 3; 4)  $\operatorname{tg}^2\alpha$ . **379.** 2)  $-\frac{1}{3}$ . **380.** 2)  $-\frac{\sqrt{3}}{2}$ ;  
4)  $\frac{\sqrt{2}(\sqrt{3}+1)}{4}$ . **381.** 2)  $\sin 2\alpha$ ; 4)  $\operatorname{tg} 2\alpha$ . **382.** 2) 1; 4)  $-\frac{1}{\sqrt{2}}$ . **383.** 2)  $-\frac{\sqrt{3}}{2}$ ;  
4)  $-1 - \frac{1}{\sqrt{2}}$ . **384.** 2)  $\cos 0 > \sin 5$ . **385.** 2) musbat; 4) manfiy. **386.** 2)  $\frac{\sqrt{2}(\sqrt{3}-1)}{4}$ ;  
4)  $\frac{\sqrt{6}-\sqrt{2}}{4}$ ; 6)  $-\frac{1}{\sqrt{2}}$ . **387.** 2)  $\frac{1}{\sin \alpha}$ . **388.**  $\cos \alpha = -\frac{2}{3}$ ;  $\operatorname{tg} \alpha = -\frac{\sqrt{5}}{2}$ ;  $\operatorname{ctg} \alpha = -\frac{2}{\sqrt{5}}$ ;  
 $\sin 2\alpha = -\frac{4\sqrt{5}}{9}$ ;  $\cos 2\alpha = -\frac{1}{9}$ . **389.** 2)  $\operatorname{tg} \alpha$ . **390.** 2)  $\frac{1}{\sin 4\alpha}$ ; 4)  $-\frac{1}{\cos 2\alpha}$ . **391.** 2) 1;  
4) 1. **392.** 2)  $-7$ . **393.** 2)  $\cos 4\alpha$ . **395.** 2)  $-3, -1, 1, 3, 5$ . **397.** 2) 79; 4)  $-42$ .  
**398.** 2)  $a_n = 29 - 4n$ ; 4)  $a_n = 6 - 5n$ . **399.** 12. **400.** Ha,  $n = 11$ . **401.**  $n = 11$ , yo'q.  
**402.** 2) 0,5. **403.** 2)  $-13$ . **404.** 2)  $-100$ . **405.** 2)  $a_n = 5n - 17$ . **406.**  $n \geq 9$ . **407.**  $n$   
 $< 25$ . **408.** 2)  $a_9 = -57$ ,  $d = 7$ ; 4)  $a_9 = -1$ ,  $d = -15$ ; **409.** 44,1 m. **410.** 10 kun. **411.**  
30. **412.** 60. **413.** 2) 10050; 4) 2550. **414.** 4850. **415.** 4480. **416.** 2)  $-192$ . **417.**  
2) 204. **418.** 2) 240. **419.** 4905; 494550. **420.** 2) 2900. **421.** 10.  
**422.** 2)  $a_{10} = 15\frac{5}{6}$ ,  $d = \frac{3}{2}$ . **423.** 2)  $a_1 = -88$ ,  $d = 18$ . **424.** 78 ta to'sin. **425.** 44.  
**426.**  $a_1 = 5$ ,  $d = 4$ . **429.** 2)  $-3, 12, -48, 192, -768$ . **431.** 2)  $\frac{1}{16}$ ; 4)  $\frac{1}{81}$ .  
**432.** 2)  $b_n = 3 \cdot \left(\frac{1}{3}\right)^{n-1}$ ; 4)  $b_n = 3 \cdot \left(-\frac{4}{3}\right)^{n-1}$ . **433.** 2) 5; 4) 8. **434.** 2) 3; 4)  $-\frac{1}{5}$ .

- 435.**  $b_n = 2374$ ,  $n = 5$ . **436.**  $b_7 = 3\sqrt{3}$ ,  $q = \frac{1}{\sqrt{3}}$ . **437.**  $b_5 = 6$ ,  $b_1 = 30\frac{3}{8}$  yoki  $b_5 = -6$ ,  
 $b_1 = -30\frac{3}{8}$ . **438.** 65910 so'm. **439.** 0,25 sm<sup>2</sup>. **440.** 2)  $-\frac{31}{8}$ ; 4)  $-\frac{275}{81}$ ;  
 6) -400. **441.** 2) 2186. **442.** 2)  $b_1 = -1$ ,  $b_8 = 128$ . **443.** 2)  $n = 7$ ; 4)  $n = 5$ . **444.** 2)  $n =$   
 9,  $b_9 = 2048$ ; 4)  $n = 5$ ,  $q = 7$ . **445.** 2) 364; 4) 305. **446.** 2)  $b_5 = 4802$ ,  $S_4 = 800$ .  
**447.**  $-1\frac{31}{32}$ . **449.** 2)  $q = 5$ ,  $b_3 = 300$  yoki  $q = -6$ ,  $b_3 = 432$ . **450.** 2)  $q = 2$  yoki  $q = -2$ ;  
 4)  $S_5 = 781$  yoki  $S_5 = 521$ . **452.** 2) ha; 4) ha. **453.** 2) 7,2; 4)  $-8\frac{1}{6}$ . **454.** 2)  $\frac{27}{4}$ ;  
 4)  $\frac{2}{3}$ . **455.** 2) yo'q; 4) ha. **456.**  $90\frac{10}{11}$ . **457.** 2)  $6 + 4\sqrt{3}$ . **458.** 2)  $\frac{1}{2}$ ; **459.**  $2a$ .  
**460.**  $R_n = \frac{1}{3^{n-1}} \cdot R_1$ . **461.** 2) 1; 4)  $\frac{7}{30}$ . **462.** 2)  $d = -\frac{1}{2}$ ,  $a_4 = 2$ ,  $a_5 = 1\frac{1}{2}$ ; 4)  $d = -3$ ,  
 $a_4 = \sqrt{2} - 9$ ,  $a_5 = \sqrt{2} - 12$ . **464.**  $-5\frac{1}{3}$ . **465.** 2) -1080. **466.** 143. **467.** 2) -22.  
**468.** 2)  $q = -\frac{1}{2}$ ,  $b_4 = -\frac{1}{32}$ ,  $b_5 = \frac{1}{64}$ ; 4)  $q = -\sqrt{2}$ ,  $b_4 = -10\sqrt{2}$ ,  $b_5 = 20$ .  
**469.** 2)  $b_n = -0,5 \cdot (-2)^{n-1}$ . **470.** 2)  $b_n = \frac{125}{8}$ . **471.** 2)  $S_{10} = 1\frac{85}{256}$ ; 4)  $S_9 = 5$ .  
**472.** 2) 242; 4)  $\frac{65}{36}$ . **473.**  $-\frac{4}{5}$ . **474.**  $24\frac{41}{74}$ . **475.** 2) 14, 11, 8, 5, 2. **476.**  $-\frac{5}{2}$ .  
**477.** 2)  $a_{19} = 0$ ,  $a_1 = -108$ . **478.** 2)  $x_1 = \frac{1}{3}$ ; 4)  $x_2 = -4$ . **480.** 14. **481.** 2)  $a_{16} = -1\frac{2}{3}$ ,  
 $d = -\frac{2}{15}$ . **482.** 2) 27. **483.** 2) -27; 4)  $\pm\frac{1}{25}$ . **484.** 6. **485.** 2) Yo'q; 4) Ha.  
**487.** Chorshanba kuni. **488.**  $a_1 = 8$ ,  $d = -3$  yoki  $a_1 = 2$ ,  $d = 3$ . **489.**  $a_1 = 5$ ,  $d = -5$   
 yoki  $a_1 = -5$ ,  $d = 5$ . **490.** 180 marta. **495.** 2)  $-15 < x < 2$ ; 4)  $x \leq 12$ ,  $x \geq 12$ ;  
**496.** 2)  $0 < x < \sqrt{5}$ ; 4)  $x < -\sqrt{3}$ ;  $x > \sqrt{3}$ . **497.** 2)  $-9 < x < 6$ ; 4)  $-2 < x < 0,1$ ;  
 6)  $x \leq \frac{1}{8}$ ,  $x \geq 2$ . **498.** 2)  $x = -12$ ; 4)  $x$  - istalgan haqiqiy son; 6) yechimlari yo'q.  
**499.** 2)  $x$  - istalgan haqiqiy son; 4)  $x$  - istalgan haqiqiy son; 6)  $x$  - istalgan  
 haqiqiy son. **500.** 2)  $-0,7 < x < \frac{1}{2}$ ; 2)  $-2 \leq x \leq 1$ . **501.** 2)  $x \leq -2$ ,  $x = 1$ ; 4)  $x \leq -\frac{1}{3}$ ,  
 $0 \leq x \leq 2$ . **502.** 2)  $-0,5 \leq x < 2$ ; 4)  $-3 < x < 0$ ,  $x > 1$ . **503.** Balandlik 3,1 sm dan ortiq,  
 o'rta chiziq 6,2 sm dan ortiq. **504.** 8 s dan ortiq. **505.** 5 sm ortiq. **506.** 2)  $x < -7$ ,  
 $-1 \leq x \leq 2$ ; 4)  $-1 \leq x < -\frac{1}{3}$ ,  $x > \frac{1}{3}$ . **507.**  $p = 5$ ,  $q = -14$ . **508.** 2)  $p = 14$ ,  $q = 49$ .  
**509.**  $y = -2x^2 + 11x - 5$ . **510.**  $y = \frac{n}{r^2}x^2$ . **511.** 2)  $a = -1$ ,  $b = -1$ ,  $c = 2$ .

**512. Ko'rsatma.** 1)  $\frac{a}{b} = A^3$ ,  $\frac{b}{c} = B^3$ ,  $\frac{c}{a} = C^3$  kabi belgilab va  $ABC = 1$  tenglikni hisobga olib, berilgan tengsizlikni  $A^3 + B^3 + C^3 \geq 3ABC$  ko'rinishda yozing, uni  $(A+B+C)(A^2 + B^2 + C^2 - AB - AC - BC) \geq 0$  ko'rinishda almashtiring. ( $A^2 + B^2 + C^2 \geq AB+AC+BC$  tengsizlik ushbu  $A^2 + B^2 \geq 2AB$ ,  $A^2 + C^2 \geq 2AC$ ,  $B^2 + C^2 \geq 2BC$  tengsizliklarni qo'shish bilan hosil qilinadi; 2) o'rta arifmetik va o'rta geometrik

miqdorlarga doir tengsizliklarni qo'shing:  $\frac{bc}{a} + \frac{ac}{b} \geq 2c$ ,  $\frac{ac}{b} + \frac{ab}{c} \geq 2a$ ,  $\frac{ab}{c} + \frac{bc}{a} \geq 2b$ ;

3) tengsizlikning chap qismidan o'ng qismini ayirib va hosil bo'lgan kasrning suratini bunday ko'rinishda yozing:  $(a+b)(a-b)^2 + (b+c)(b-c)^2 + (a+c)(a-c)^2$ ;

1)  $x_{1,2} = \pm 2$ ; 2)  $x_{1,2} = \pm 1$ ; 3)  $x_{3,4} = \pm 3$ ; 3)  $x_1 = -1$ ,  $x_2 = 2$ ; 4)  $x_{1,2} = \frac{-1 \pm \sqrt{5}}{2}$ ;

5)  $x_1 = 0$ ,  $x_{2,3} = \pm 2$ ; 6)  $x_{1,2} = \pm 4$ ,  $x_{3,4} = \pm 6$ . **516.** 2)  $2\frac{1}{3}$ ; 4)  $\frac{2x^2}{3y}$ . **517.** 2)  $3 - \sqrt[3]{2}$ ;

4)  $6\sqrt{7}$ . **518.** 2)  $(2\sqrt{0,5})^{0,4} < (2\sqrt{0,5})^{0,37}$ . **519.** 2)  $\sqrt{x}$ ; 4)  $9b^{-4}$ . **520.** 2)  $5ab\sqrt{b}$ ;

4)  $2ab\sqrt{ab}$ . **521.** 2)  $-\sqrt{3x^2}$ ; 4)  $\sqrt{5a^2}$ . **522.** 2)  $-8\frac{1}{8}$ . **523.** 2)  $-1\frac{5}{6}$ . **524.** 2)  $x = \frac{1}{9}$ ;

2)  $x = 0$ . **525.** 2) Yo'q; **526.** 2) Yo'q. **527.** 2)  $1,5 < x \leq 7$ ; 4)  $x \geq -7,5$ ; 6)  $0 \leq x < 2$ ,

$x > 2$ . **530.** -1. **531.** 2) Manfiy. **532.** 2) -0,8. **533.** 2)  $2\sin\frac{3\alpha}{4}\cos\frac{\alpha}{4}$ ;

4)  $\sin\alpha(\sin\alpha - 2\cos\alpha)$ . **534.**  $\sin\alpha = \frac{240}{289}$ ,  $\cos\alpha = -\frac{161}{289}$ ,  $\operatorname{tg}\alpha = -\frac{240}{161}$ . **535.** 2)  $a_{12} = 47,5$ ,

$S_{12} = 537$ ; 4)  $a_{18} = 11\frac{2}{3}$ ,  $S_{18} = 108$ . **536.** 1220. **538.** 2)  $b_1 = 5$ . **539.** 2)  $b_1 = 125$ ,

$S_4 = 156$ ; 4)  $b_4 = 81$ ,  $S_5 = 61$ . **540.**  $15\frac{3}{4}$ . **541.** 2)  $4\frac{1}{6}$ ; 4) 1; 6)  $-\frac{5}{4}(1 + \sqrt{5})$ .

**542.** 2)  $2ab\sqrt[3]{b}$ ; 4)  $a + 3$ . **543.** 2) -1; 4)  $-\frac{1}{x}$ . **544.** Birinchisi. **545.** 2)  $\frac{(a+\sqrt{b})(\sqrt{a+\sqrt{b}})}{a^2-b}$ ;

4)  $0,1(5 - \sqrt{5})5 + \sqrt{5}$ . **546.** 2)  $-\frac{\sqrt{a}}{b}$ ; 4)  $\sqrt{a} + \sqrt{b}$ . **547.** Kamayadi. **548.** 2)  $x \leq 0$ ,

$x \geq 6$ ; 4)  $x \neq \sqrt{3}$ ; 6)  $x \leq -3$ ,  $0 < x < 2$ ,  $x \geq 3$ . **550.** 2)  $x = 61$ ; 4)  $x = 0,5$ ; 6)  $x_1 = 0$ ,

$x_2 = -3$ ,  $x_3 = 2$ . **551.** 2)  $\frac{1}{\cos^2\alpha}$ ; 4) 4. **552.** 2)  $\cos^2x$ . **553.** 2)  $x = \frac{\pi}{2} + \pi n$ ,  $x = \pi + 2n$ ,  $n \in \mathbb{Z}$ .

**556.**  $\frac{\pi}{6}$ ,  $\frac{\pi}{3}$ ,  $\frac{\pi}{2}$ . **557.**  $39\frac{2}{3}$ . **558.** 7, -28, 112, -448 yoki  $-11\frac{2}{3}$ ; -46 $\frac{2}{3}$ ; -186 $\frac{2}{3}$ ; -746 $\frac{2}{3}$ .

**559.**  $b_1 = 5$ ,  $b_5 = 405$ . **560.**  $\frac{1}{8}$ . **561.** 8, 13, 18 yoki 20, 13, 6. **562.** 1)  $\frac{\sqrt{3+\sqrt{7}}}{\sqrt{2}}$ ;  $\frac{1+\sqrt{7}}{\sqrt{2}}$ .

**563.** 1)  $1 - \sqrt{a}$ ; 2)  $a^{\frac{2}{3}} + b^{\frac{2}{3}}$ . **565.**  $\sin\alpha = -\frac{120}{169}$ ,  $\cos\alpha = -\frac{119}{169}$ . **567.** 10, 4, -2, 1 yoki

$-\frac{5}{4}$ ,  $\frac{1}{4}$ ,  $\frac{7}{4}$ ,  $\frac{49}{4}$ .



**VII-IX SINFLAR ALGEBRA KURSINI TAKRORLASH  
UCHUN MASHQLARNING JAVOBLARI**

569. 2) 4; 4)  $4\frac{3}{4}$ . 570. 2) 5,8; 4)  $-\frac{1}{11}$ . 571. 2)  $x = 7$ ; 4)  $x = 0,5$ ;  $x = 2,25$ .
572. 2) 3; 4) 0,1125. 573. 2) 300; 4) 3600. 574. 2) 5%; 4)  $16\frac{2}{3}\%$ . 575. 2)  $5a^3b$ ; 4)  $4a^8b^7$ . 576. 2)  $35 - 2x - 2x^3 - x^5$ ; 4)  $8a^2 + 4b^2 + 36a + 36$ . 577. 2) 4,9; 2) 2.
578. 2)  $b^2 - 7a^3b^3$ . 579. 2)  $\left(\frac{b}{3} - 1\right)\left(\frac{b}{3} + 1\right)$ ; 4)  $(b - \sqrt{3})(b + \sqrt{3})(b^2 + 3)$ . 580. 2)  $\left(\frac{b}{2} + 1\right)^2$ ; 4)  $(1 + 9b)^2$ . 581. 2)  $(a + 1)(a - x)$ ; 4)  $(a - x)(5a - 7)$ . 582. 2)  $2a^3b(a - 1)^2$ ; 4)  $(a - b)^2(a + b)^2$ . 583. 2)  $2(x - 3)^2$ ; 4)  $(x - 1)(x + 2)$ . 584. 2)  $\frac{b+3}{3b}$ ; 4)  $\frac{3y}{4x}$ ;
- 6)  $\frac{x+4}{x+5}$ ; 8)  $\frac{x-1}{x+2}$ . 585. 2)  $\frac{3}{2}m^2$ ; 4)  $\frac{3c^2}{k^3}$ ; 6)  $\frac{15a}{4c}$ ; 8)  $(x + 1)(x - 2)$ . 586. 2)  $\frac{6-5a}{a^2-4}$ ;
- 4)  $\frac{3b-a^2}{a(b^2-a^2)}$ . 587. 2)  $\frac{1}{2a+3}$ ; 4)  $b + a - 1$ . 588. 2)  $\frac{2}{a(a+2)}$ ; 4)  $\frac{1}{a+1}$ . 589. 3)  $\frac{x}{y}$ ;
- 4)  $\frac{10}{2a+1}$ . 590. 2) -0,25; 4)  $1\frac{9}{16}$ . 591. 2) 3. 592. 2)  $\frac{1}{x+\sqrt{2}}$ ; 4)  $\frac{\sqrt{x}}{\sqrt{x-1}}$ . 593. 2) 4;
- 4) 8. 594. 2) -2; 4) 0; 6) 7. 595. 2) 2; 4) 14. 596. 2)  $\frac{\sqrt{3}}{11}$ ; 4)  $6\sqrt{2}$ . 597. 2)  $2 \cdot 10^{-3}$ ; 4)  $1,2 \cdot 10^{-3}$ . 598. 2) 1,25. 599. 2) 3,5. 600. 2)  $-x^2y^2$ ; 4)  $xy^2$ . 601. 2) -1;
- 4)  $1 + \sqrt{m}$ . 602. 2)  $x = 1$ ; 4)  $x = -0,5$ . 603. 2)  $x = 12\frac{1}{14}$ ; 4)  $x = -13,5$ .
604. 2)  $x = 3$ ; 4)  $x = -9$ . 605. 2)  $x_1 = -2$ ,  $x_2 = 3$ ; 4)  $x_1 = 5$ ,  $x_2 = -1$ .
606. 2)  $x_1 = 0$ ,  $x_2 = 5$ ; 4)  $x_1 = 0$ ,  $x_2 = -\frac{1}{6}$ ; 6)  $x_{1,2} = \pm 2$ ; 8)  $x_{1,2} = \pm 2\sqrt{2}$ .
607. 2)  $x_1 = -1$ ,  $x_2 = 1,5$ . 608. 2)  $x_1 = 5$ ,  $x_2 = -\frac{3}{4}$ . 609. 2)  $x_1 = 1$ ,  $x_2 = 4,5$ ;
- 4)  $x_1 = -5$ ,  $x_2 = 0,5$ . 610. 2)  $x_1 = -3$ ,  $x_2 = 5$ ; 4)  $x = -1$ ; 6)  $x_1 = 4,3$ ,  $x_2 = -11,7$ .
611. 2)  $x = 3$ ; 4)  $x = -4$ . 612. 2)  $x_{1,2} = \pm 1$ ,  $x_{3,4} = \pm 6$ . 613. 2)  $x = 33$  4)  $x = 9$ ;
- 6)  $x_1 = 1$ ,  $x_2 = 4$ . 614. 2)  $x = -2$ ; 4)  $x = 1,5$ . 615. 2)  $x = -1$ ; 4)  $x_1 = 1$ ,  $x_2 = -0,5$ ;
- 6)  $x = 4$ . 616. 2) (3; 7); 4) (2; 3); 6) (-2; -3). 617. 2) (14; 10); 4) (2; 2).
618. 2) (5; 3), (-3; -5); 4) (4; -9), (-9; 4); 6) (4; 5), (-4; -5), (5; 4), (-5; -4).
619. 2)  $x \leq \frac{22}{27}$ ; 4)  $x > 1$ . 620. 2)  $x \leq 1$ ; 4)  $x < 3\frac{1}{6}$ ; 6)  $x < 2$ . 621. 2)  $x \geq 1,5$ ;
- 4)  $x \geq 3$ . 622. 2) 1; 2; 3; 4. 623. 2) -1; 0; 1; 2; 4) -1; 0; 1; 2; 3. 624. -4; 3;
- 2; -1. 625. 2)  $-1 \leq x \leq 3$ ; 4)  $\frac{3-\sqrt{5}}{2} \leq x \leq \frac{3+\sqrt{5}}{2}$ ; 6) yechimlari yo'q; 8)  $x < -1\frac{1}{3}$ ,

$x > 1$ . **626.** 2)  $-1\frac{1}{3} < x < 3\frac{1}{3}$ ; 4)  $-1 \leq x \leq 3$ . **627.** 1)  $-4 < x < 2$ ; 4)  $0 < x < 7$ ,  
 $x > 8$ ; 6)  $x \leq -3$ ,  $-0,5 \leq x \leq 0,5$ . **628.** 2)  $9 > 4\sqrt{5}$ ; 4)  $5\sqrt{6} < 6\sqrt{5}$ ;  
 6)  $2\sqrt[3]{3} < \sqrt{2} \cdot \sqrt[3]{5}$ . **629.** 62,5 va 57,5. **630.** 5 km/soat. **631.** 4 km/soat.  
**632.** 12,5 km/soat, 2,5 km/soat. **633.** 26 sm, 2sm. **634.** 48 min. **635.** 20 min.  
**636.** 35 sr. **637.** 5 soat, 7 soat. **638.** 2) Ha; (0; -4), (8; 0),  $y(-2) = -5$ ; 4) yo'q;  
 (0; 6), (4; 0),  $y(-2) = 9$ . **641.** 2) 5; -10); 4)  $(\frac{5}{4}; -\frac{1}{8})$ . **642.** 2) 23; 4)  $6\frac{1}{4}$ .  
**643.** 2)  $x_1 = -2$ ,  $x_2 = -5$ . **645.**  $\sqrt[3]{-\frac{2}{9}} < \sqrt[3]{-\frac{1}{7}}$ . **647.** 2)  $\frac{5\pi}{4} + 2\pi n$ ,  $n \in \mathbf{Z}$ ; 4)  $7\pi + 2\pi n$ ,  
 $n \in \mathbf{Z}$ . **648.** 2. **650.** 2)  $2\cos^2\alpha$ . **651.**  $-\operatorname{tg}2\alpha$ . **653.** 2)  $\frac{7}{9}$ . **654.** 2) 0,5. **655.** 2)  $\frac{3}{8}$ .  
**656.** 7. **657.** 1) 0; 2) 0. **658.**  $-\sin\alpha - \cos\alpha$ . **659.** -2. **660.** -0,5. **661.** 2)  $a_1 = 201$ ,  
 $S_{17} = 2737$ . **662.**  $n = 39$ . **663.** 682. **664.** 2) 0,5; 4) 1. **665.** 189. **666.** 2)  $a_1 = 1$ ,  
 $d = 3$ ; 4)  $a_1 = 2$ ,  $d = 3$  yoki  $a_1 = 14$ ,  $d = -3$ ; **671.**  $b_n = 3(-\frac{1}{6})^{n-1}$  yoki  $b_n = -3(\frac{1}{6})^{n-1}$ .  
**672.**  $b_4 = 12$ ,  $q = -2$  yoki  $b_4 = -12$ ,  $q = 2$ . **673.**  $\frac{1}{3}$ ; 1; 3; 9; 27 yoki  $\frac{1}{3}$ ; -1; 3;  
 -9; 27. **674.** 1)  $b_1 = 0,384$ ,  $q = 0,25$  yoki  $b_1 = 0,6$ ,  $q = -0,2$ . **675.** 2)  $b_1 = 37,5$ ,  
 $q = 0,6$  yoki  $b_1 = 48$ ,  $q = 0,25$ . **676.** 2) 11; 4) 341 yoki 121.

### «O'zingizni tekshirib ko'ring» topshiriqlariga javoblar

**I bob. 1.** 84-rasm. **2.**  $x_1 = 0$ ,  $x_2 = 2$ . **3.**  $-1 < x < 1$  bo'lganda  $y > 0$ ;  $x < -1$   
 bo'lganda  $y < 0$ ;  $x > 1$ . **4.**  $x > 0$  bo'lganda funksiya o'sadi;  $x < 0$  bo'lganda  
 funksiya kamayadi. **5.** (3; 0); 85-rasm.

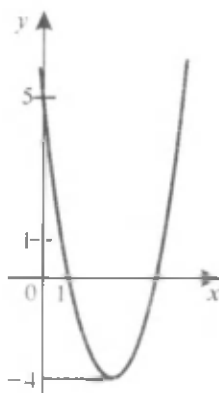

84-rasm.

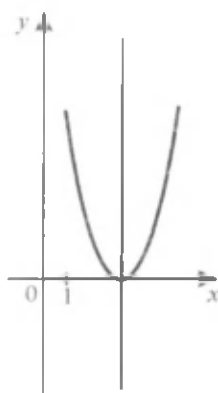

85-rasm.

**II bob. 1.** 1)  $-1 < x < 4$ ; 2)  $x$  – istalgan haqiqiy son; 3) yechimlari yo‘q; 4)  $x = -10$ . **2.**  $x \geq 1$ ;  $-2 \leq x \leq 0$ .

**III bob. 1.** 1)  $8\frac{3}{8}$ ; 2) 16. **2.**  $8,6 \cdot 10^3$ ;  $7,8 \cdot 10^{-3}$ ;  $6,708 \cdot 10^1$ ;  $1,1 \cdot 10^6$ .  
**3.** 1) 6; 2)  $(y + x)xy$ . **4.**  $a^{\frac{3}{4}}$ ; 27. **5.**  $(0,78)^{\frac{2}{3}} > (0,67)^{\frac{2}{3}}$ ;  $(3,09)^{\frac{1}{3}} < (3,08)^{\frac{1}{3}}$ .

**IV bob. 1.** 1)  $x \neq 1$ ; 2)  $-3 \leq x \leq 3$ . **2.** a) 1)  $y = 1,4$ ; 2)  $y = 3$ ; 3)  $y = -2,5$ ; 4)  $y = 8$ ;  
 b) 1)  $x = 9$ ; 2)  $x = 2$ ; 3)  $x = -\frac{5}{3}$ ; 4)  $x = \sqrt[3]{3}$ ; d)  $y(x) > 0$  ushbu hollarda bo‘ladi:

1)  $x > 0$ ; 2)  $x > 0$ ; 3)  $x < 0$ ; 4)  $x > 0$ ;  $y(x) < 0$  ushbu hollarda bo‘ladi: 1) bunday oraliqlar yo‘q; 2)  $x < 0$ ; 3)  $x > 0$ ; 4)  $x < 0$ ; e) funksiya ushbu hollarda o‘sadi: 1)  $x \geq 0$ ; 2) bunday oraliqlar yo‘q; 3)  $x > 0$ ,  $x < 0$ ; 4)  $x \in \mathbb{R}$ ; funksiya ushbu hollarda kamayadi: 1) bunday oraliqlar yo‘q; 2)  $x > 0$ ,  $x < 0$ ; 3) oraliqlar yo‘q; 4) bunday oraliqlar yo‘q; **3.** 1) juft; 2) toq. **4.** 1)  $x = 28$ ; 2)  $x = 1$ .

**V bob. 1.**  $\cos \alpha = -\frac{3}{5}$ ,  $\operatorname{tg} \alpha = -\frac{4}{3}$ ,  $\sin 2\alpha = -\frac{24}{25}$ . **2.** 1) 1; 2)  $-\frac{\sqrt{3}}{2}$ ; 3)  $\frac{\sqrt{3}}{2}$ ;  
 4)  $-\sqrt{3}$ ; 5)  $\frac{\sqrt{2}}{2}$ . **5.** 1)  $\sin \alpha \cos \beta$ ; 2)  $\cos^2 \alpha$ ; 3)  $2 \sin \alpha$ .

**VI bob. 1.**  $a_{10} = -25$ ,  $S_{10} = -115$ . **2.**  $b_6 = \frac{1}{8}$ ,  $S_6 = 7\frac{7}{8}$ . **3.**  $q = \frac{1}{3}$ ,  $S = 1,5$ .

### I–VI boblar sinov (test) mashqlariga javoblar kaliti

1	2	3	4	5	6	7	8	9	10	11	12	13	14	15	16	17	18	19	20	21	22	23	24	25
A	B	C	D	E	A	B	C	D	E	A	B	C	D	E	A	B	C	D	E	A	B	C	D	E

## Tushunchalar ko'rsatkichi

- Aniqlanish sohasi 76  
Argument 76  
Ayniyat 128  
  – trigonometrik 124  
Birlik aylana 109  
Burish 109  
Burchakning:  
  – kosinusi 115  
  – radian o'lchovi 106  
  – sinusi 115  
  – tangensi 117  
Erkli o'zgaruvchi 76  
Funksiya 76  
  – davriy 143  
  – darajali 76  
  – grafigi 77  
  – juft 85  
  – kamayuvchi 81  
  – toq 87  
  – trigonometrik 119  
  – o'suvchi 81  
Giperbola 90  
Ildiz 53  
Intervallar usuli 38  
Irratsional ko'rsatkichli daraja 81  
Keltirish formulalari 141  
Kosinuslar yig'indisi va ayirmasi 146  
Kub ildiz 55  
Kvadrat funksiya 5, 16  
Kvadrat funksiyaning nollari 6  
Kvadrat ildiz 53  
Kvadrat tengsizlik 29  
Manfiy ko'rsatkichli daraja 48  
Nol ko'rsatkichli daraja 48  
 $n$ -darajali arifmetik ildiz 53  
Parabola 7  
Parabolaning fokusi 9  
Parabolaning uchi 8  
Parabolaning simmetriya o'qi 8  
Progressiya 157  
  – arifmetik 157  
  – ayirmasi 158  
  – dastlabki  $n$  ta hadining yig'indisi 162, 171  
  – geometrik 166  
  – maxraji 167  
  – cheksiz kamayuvchi geometrik 176  
Ratsional ko'rsatkichli daraja 48, 59  
Sinuslar yig'indisi va ayirmasi 145

## Ismlar ko'rsatkichi

- Abu Rayhon Beruniy 75, 104, 124, 155, 156, 186  
Al Farg'oniy 156  
Al Xorazmiy 156  
Bernulli 104  
Buzjoniy 155  
Eyler 75  
Leybnis 104  
Lobachevskiy 104  
Mirzo Ulug'bek 156  
Nyuton 75  
G'iyosiddin Jamshid al-Koshiy 52, 75, 155, 186

## MUNDARIJA

7-8- sinflarda o'rganilgan mavzularni takrorlash .....	3
--	---

### I bob. KVADRAT FUNKSIYA

1-§. Kvadrat funksiyaning ta'rifi .....	5
2-§. $y = x^2$ funksiya .....	7
3-§. $y = ax^2$ funksiya .....	10
4-§. $y = ax^2 + bx + c$ funksiya .....	14
5-§. Kvadrat funksiyaning grafigini yasash .....	18
<i>I bobga doir mashqlar</i> .....	24
<i>I bobga doir sinov (test) mashqlari</i> .....	26

### II bob. KVADRAT TENGSIZLIKLAR

6-§. Kvadrat tengsizlik va uning yechimi .....	29
7-§. Kvadrat tengsizlikni kvadrat funksiya grafigi yordamida yechish .....	33
8-§. Intervallar usuli .....	38
<i>II bobga doir mashqlar</i> .....	42
<i>II bobga doir sinov (test) mashqlari</i> .....	45

### III bob. RATSIONAL KO'RSATKICHLI DARAJA

9-§. Butun ko'rsatkichli daraja .....	48
10-§. Natural ko'rsatkichli darajaning arifmetik ildizi .....	52
11-§. Arifmetik ildizning xossalari .....	56
12-§. Ratsional ko'rsatkichli daraja .....	59
13-§. Sonli tengsizliklarni darajaga ko'tarish .....	66
<i>III bobga doir mashqlar</i> .....	70
<i>III bobga doir sinov (test) mashqlari</i> .....	72
<i>Tarixiy ma'lumotlar</i> .....	75

### IV bob. DARAJALI FUNKSIYA

14-§. Funksiyaning aniqlanish sohasi .....	76
15-§. Funksiyaning o'sishi va kamayishi .....	80
16-§. Funksiyaning juftligi va toqligi .....	85
17-§. $y = \frac{k}{x}$ funksiya .....	90
18-§. Daraja qatnashgan tengsizlik va tenglamalar .....	94

<i>IV bobga doir mashqlar</i> .....	98
<i>IV bobga doir sinov (test) mashqlari</i> .....	101
<i>Tarixiy ma'lumotlar</i> .....	104
<b>V bob. TRIGONOMETRIYA ELEMENTLARI</b>	
19-§. Burchakning radian o'lchovi.....	105
20-§. Nuqtani koordinatalar boshi atrofida burish.....	109
21-§. Burchakning sinusi, kosinusi, tangensi va kotangensi ta'riflari.....	115
22-§. Sinus, kosinus va tangensning ishoralari.....	121
23-§. Ayni bir burchakning sinusi, kosinusi va tangensi orasidagi munosabatlar.....	124
24-§. Trigonometrik ayniyatlar.....	128
25-§. $\alpha$ va $-\alpha$ burchaklarning sinusi, kosinusi, tangensi va kotangensi.....	131
26-§. Qo'shish formulalari.....	132
27-§. Ikkilangan burchakning sinusi va kosinusi.....	137
28-§. Keltirish formulalari.....	140
29-§. Sinuslar yig'indisi va ayirmasi. Kosinuslar yig'indisi va ayirmasi.....	145
<i>V bobga doir mashqlar</i> .....	148
<i>V bobga doir sinov (test) mashqlari</i> .....	152
<i>Tarixiy masalalar</i> .....	155
<i>Tarixiy ma'lumotlar</i> .....	156
<b>VI bob. PROGRESSIYALAR</b>	
30-§. Arifmetik progressiya.....	157
31-§. Arifmetik progressiya dastlabki $n$ ta hadining yig'indisi.....	162
32-§. Geometrik progressiya.....	166
33-§. Geometrik progressiya dastlabki $n$ ta hadining yig'indisi.....	171
34-§. Cheksiz kamayuvchi geometrik progressiya.....	175
<i>VI bobga doir mashqlar</i> .....	181
<i>VI bobga doir sinov (test) mashqlari</i> .....	184
<i>Tarixiy masalalar</i> .....	186
<i>Tarixiy ma'lumotlar</i> .....	186
IX sinf «Algebra» kursini takrorlash uchun mashqlar.....	187
VII–IX sinflar «Algebra» kursini takrorlash uchun mashqlar.....	197
VII–VIII sinflar «Algebra» kursi bo'yicha qisqacha nazariy ma'lumotlar ...	210
Javoblar.....	225
Tushunchalar ko'rsatkichi.....	236
Ismlar ko'rsatkichi.....	236

**Alimov Sh.A.**

Algebra: Umumiy ta'lim maktablarining 9- sinfi uchun darslik/Sh.A.Alimov, A.R.Xalmuxamedov, M.A.Mirzaxmedov. – Qayta ishlangan va to'ldirilgan nashri. – T.: «O'qituvchi» NMIU, 2006. – 240 b.

I. 1,2 Muallifdosh

BBK 22.14ya721

**Shavkat Arifdjanovich Alimov,  
Alimdjan Raximovich Xalmuxamedov,  
Mirfazil Abdilxakovich Mirzaxmedov**

## **ALGEBRA**

Umumiy ta'lim maktablarining  
9- sinfi uchun darslik

Qayta ishlangan va to'ldirilgan nashri

*«O'qituvchi» nashriyot-matbaa ijodiy uyi  
Toshkent – 2006*

Tahririyat mudiri *M.Po'latov*

Muharrir *O'.Husanov*

Muqova rassomi *Sh.Xo'jayev*

Rasmlar muharriri *Sh.Rahimqoriyev*

Tex.muharrir *T.Greshnikova*

Kichik muharrir *H.Musaxo'jayeva*

Kompyuterda sahifalovchi *Sh.Rahimqoriyev*

Musahhah *Z.Sodiqova*

**IB № 8697**

Original-maketdan bosishga ruxsat etildi 10.02.2006. Bichimi 70×90<sup>1</sup>/<sub>16</sub>. Kegli 11 shponli. SchoolBook garniturası. Ofset bosma usulida bosildi. Shartli b.t. 17,55. Nashr t. 15,0. 496 400 nusxada bosildi. Buyurtma № 34.

O'zbekiston Matbuot va axborot agentligining «O'qituvchi» nashriyot-matbaa ijodiy uyi. Toshkent-129. Navoiy ko'chasi, 30- uy.//Toshkent, Yunusobod dahasi, Murodov ko'chasi, 1-uy. Shartnoma № 09-268-05.

## Ijaraga berilgan darslik holatini ko'rsatuvchi jadval

T/r	O'quvchining ismi va familiyasi	O'quv yili	Darslikning olingandagi holati	Sinf rahbari-ning imzosi	Darslikning topshirilgan-dagi holati	Sinf rahbari-ning imzosi
1						
2						
3						
4						
5						
6						

**Darslik ijaraga berilib, o'quv yili yakunida qaytarib olinganda yuqoridagi jadval sinf rahbari tomonidan quyidagi baholash mezonlariga asosan to'ldiriladi:**

Yangi	Darslikning birinchi marotaba foydalanishga berilgandagi holati.
Yaxshi	Muqova butun, darslikning asosiy qismidan ajralmagan. Barcha varaqlari mavjud, yirtilmagan, ko'chmagan, betlarida yozuv va chiziqalar yo'q.
Qoniqarli	Muqova ezilgan, birmuncha chizilib, chetlari yedirilgan, darslikning asosiy qismidan ajralish holati bor, foydalanuvchi tomonidan qoniqarli ta'mirlangan. Ko'chgan varaqlari qayta ta'mirlangan, ayrim betlariga chizilgan.
Qoniqarsiz	Muqovaga chizilgan, u yirtilgan, asosiy qismidan ajralgan yoki butunlay yo'q, qoniqarsiz ta'mirlangan. Betlari yirtilgan, varaqlari yetishmaydi, chizib, bo'yab tashlangan. Darslikni tiklab bo'lmaydi.