

**O'ZBEKISTON RESPUBLIKASI QISHLOQ VA
SUV XO'JALIGI VAZIRLIGI**

**SAMARQAND QISHLOQ XO'JALIK
INSTITUTI**

**Qishloq xo'jaligini mexanizatsiyalash va mahsulotlarni
qayta ishlash fakulteti**

**«Umumiy texnika fanlari va hayot faoliyati xavfsizligi»
kafedrası**

«MASHINA GRAFIKASI»

fanidan topshiriqlarni bajarish bo'yicha

USLUBIY KO'RSATMA

5 – 8 mavzular



Samarqand 2015

Ushbu uslubiy ko'rsatma Qishloq xo'jaligini mexanizatsiyalash va mahsulotlarni qayta ishlash fakulteti kengashining «___» _____ 20___ yil №___ - sonli yig'ilishida ko'rib chiqilgan.

Ko'rsatmada Mashina grafikasifani bo'yicha amaliy mashg'ulotlar uchun bo'lib, 5430100 – «Qishloq xo'jaligini mexanizatsiyalash» bakalavr yo'nalishi bo'yicha ta'lim olayotgan talabalarga Mashina grafikasifanidan amaliy topshiriqlarni bajarishda foydalanishlari uchun mo'ljallangan.

Uslubiy ko'rsatma keltirilgan amaliy topshiriqlari mavzulari namunaviy dastur asosida tayyorlangan.

Tuzuvchilar:

Boboyev O'P., t.v.n.
Mamanazarov A.S., assistent.

Taqrizchilar:

Suleymanov B.S., «Samarqand avtomobil zavodi» dotsent
Nurmixonmedov B.U., SamQXI «QXM,F va T» kafedrasida dotsenti

MAVZU №5: PARAMETRIZATSIYA PANELI BILAN ISHLASH VA TASHQI OB'EKTLARNI YUKLASH

Parametrizatsiya – buikki o'lchovli geometriya qo'llaniladigan bir biriga bog'likligi va cheklovlar bo'lgan texnologiyasi. Parametrizatsiya AutoCAD ichida 2010 versiyasi paydo bo'ldi va chizmachilik yuqori talabli asboblari biriga aylandi.

Parametrizatsiyaning barcha buyruqlari bir hil nomli vkladkada joylashgan «Параметризация» (Parametric), buyruqlar uch bo'limdan iborat:







- *геометрическая*- geometrik (geometrical);
- *размерная*- o'lchovli (dimensional);
- *управление* - boshqaruv (manage).



Yuqorida aytilganidek, geometrik parametrizatsiya ob'ektlar geometriyasi o'rtasida aniq bir bog'likligi o'rnatish imkonini beradi. Misol uchun, geometrik parametrizatsiya buyruqlar yordamida avtomatik ravishda parallel, perpendikulyar moslamalarni qilishi mumkin yoki bir-biriga kollinear. AutoCADda geometrik parametrizatsiya barcha mavjud buyruqlar quyidagi jadvalda ko'rsatilgan.









Geometrik bog'liqliklar

Nomlanishi	Buyruq ko'rinishi	Lentada joylashishi	Harakati
Mosligi		Parametrizatsiya-Geometrik-Mosligi	Ikki nuqtaning mosligi yoki nuqtalarning ob'ektga qarashligi yoki ob'ektning davomi
Kollinearlik		Parametrizatsiya-Geometrik-Kollinearlik	Yagona bir chiziq bo'ylab ikki yoki undan ko'p chiziq qismlari joylashtirish
konsentriklik		Parametrizatsiya-Geometrik-Konsentriklik	Bir xil markaziy nuqtaga orqali, ikkita doira, ikkitaduga yoki ellipslarni bir-biriga bog'lash
Tenglik		Parametrizatsiya-Geometrik-Tenglik	Tanlangan shatrlar uchun tanlangan yo'nlari va doiralar, yoki bir xil uzunlikda uchun bir xil radius tanlash
Fiksatsiya		Parametrizatsiya-Geometrik-Fiksatsiya	Nuqtava egrining turgan joyini qulflash

Nomlanishi	Buyruq ko'rinishi	Lentada joylashishi	Harakati
Gorizontalik		Parametrizatsiya-Geometrik-Gorizontalik	Chiziq laryoki juft nuqtalarning joriy koordinatati zimi Xo' qigaparallel joylashtirish
Parallelik		Parametrizatsiya-Geometrik-Parallelik	Tanlangan chiziq laro'rtasidagi parallelik
Perpendikulyarlik		Parametrizatsiya-Geometrik-Perpendikulyarlik	Tanlangan chiziq larni bir-biriga 90^0 gradusli burchak ostida joylashtirish
Silliqlik		Parametrizatsiya-Geometrik-Silliqlik	Splayndi kesma, duga, poliliniya yoki splayngacha ozaytirish
Simmetriya		Parametrizatsiya-Geometrik-Simmetriya	Tanlangan kesmaga nisbatan tanlangan ob'ektlarni simmetrik joylashtirish
Urinish		Parametrizatsiya-Geometrik-Urinish	Ikkita ob'ekni bir-biriga urinishi, misol uchun dugani kesmaga
Vertikalik		Parametrizatsiya-Geometrik-Vertikalik	Chiziq laryoki juft nuqtalarning joriy koordinatati zimi Yo' qigaparallel joylashtirish

Geometrik parametrizatsiya buyrug'ini bir qator ob'ektlarda qo'llash mumkin, asosiysi ular bir-biriga zid bo'masligi (ya'ni, ikki ob'ekt bir xil ob'ektga, ham parallel va perpendikulyar bo'lishi mumkin emas). Bog'liqliklar o'rnatilib bo'lgandan so'ng, tegishli belgi paydo bo'ladi. Agar ularning ustidan sichqonchani olib borsa ular yonadi, agar «X» bosilsabelgi yo'qoladi.

Qalamdan foydalanganda avtomatik ravishda ob'ektlarni o'lchamlari qayta o'zgarishi va ob'ektdagi bog'liqlarni qayta sanab chiqadi. Bundan tashqari, o'lchovga qo'lda qiymat kiritish mumkin va ob'ekt avtomatik ravishda (operatsiya juda qulay) mos qiymat bilan o'zgaradi. Identifikatorlari va uning o'rniga bu identifikatorlari boshqa bog'liqliklarga murojaat qilish mumkin, iboralar joriy etilishi bilan ularning kattalik qiymatlari kiritiladi. Chop etishda o'lchovli cheklovlar aks ettirilmaydi.

Nomlanishi	Buyruq ko'rinishi	Lentada joylashishi	Harakati
Chiziqli		Parametrizatsiya-O'lchamli-Chiziqli	Limited masofa vertikal yoki gorizontal nuqtalari orasidagi.
Gorizontalik		Parametrizatsiya-O'lchamli-Gorizontalik	Bir xil yoki turli xil ob'ektlar bo'yicha ikki nuqta orasidagi x-tizmasiga masofa farqni chegaralanishi
Vertikalik		Parametrizatsiya-O'lchamli-Vertikalik	Bir xil yoki turli xil ob'ektlar bo'yicha ikki nuqta orasidagi Y o'qi bo'ylab masofalarga farqni kamaytiradi.
Rostlash		Parametrizatsiya-O'lchamli-Rostlash	Overlay bir xil yoki turli xil ob'ektlar bo'yicha ikki nuqta orasidagi masofa qarab.
Burchak bo'ylab		Parametrizatsiya-O'lchamli-Burchak bo'ylab	Ob'ektlar bo'yicha uch nuqta orasidagi ko'p tilda nusrati, yoylari yoki markaziy burchagi segmentlarning yoki segmentlar o'rtasida burchak bog'liqligi
Radius		Parametrizatsiya-O'lchamli-Radius	Aylana yoki kamon radiusi chegaralanishi.
Diametr bo'ylab		Parametrizatsiya-O'lchamli-Diametr bo'ylab	Aylana yoki kamon diametri chegaralanishi.
Aylantirish		Parametrizatsiya-O'lchamli-Aylantirish	Hajmi qarab normal hajmi o'zgartirish.

Tashqi ob'ektlarni yuklash

Tashqi ob'ektlarni uyqlash uchun «Вставка» bo'limini tanlanash lozim, quydagi formatlarni uyqlash mumkin dwg, dws, dxf, dwt, jpg, pdf va boshqalar. «Вставка» bo'limidan foydalanmasdan ham ob'ektlarni AutoCAD dasturiga uyqlash mumkin buning uchun ob'ektni «Копировать»– Nusxa olish kerak sungra «Вставить» buyrug'idan foydalangan holga AutoCADning maqul bo'lgan muhitga joylashtirish lozim.

Topshiriqlarni bajarish tartibi

1. Frontal qirqimning yarimini old tomonidan ko'rishni ayrim bilan bog'lash.
2. Chap tomonidan ko'rishni A-A qirqim bilan almashtirish.
3. Old tomonidan ko'rishni A-A qirqim bilan almashtirish

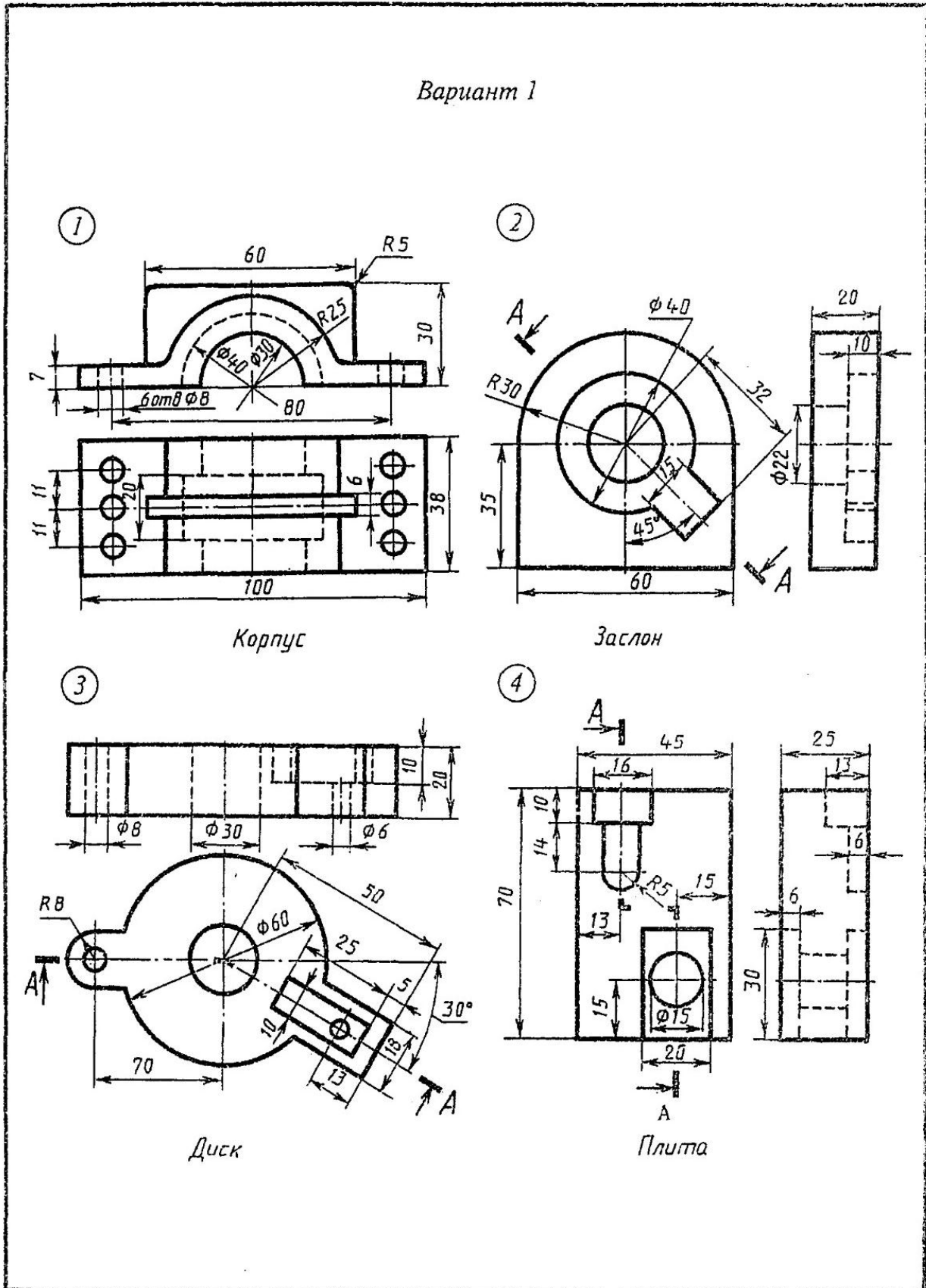

Вариант 2

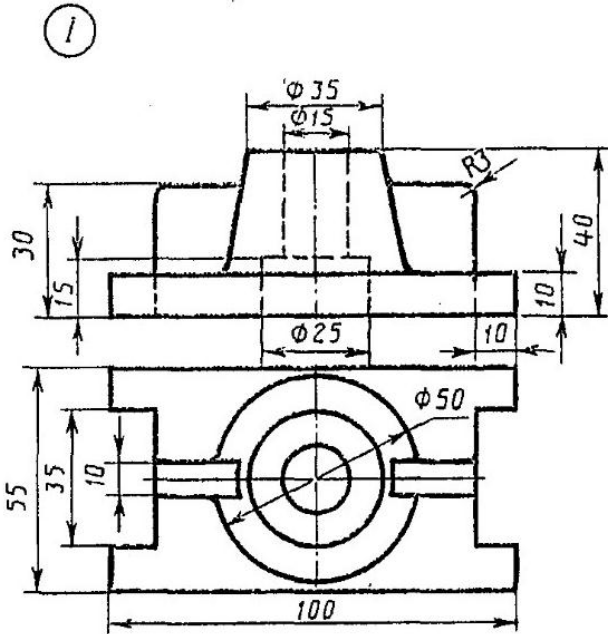

Стійка

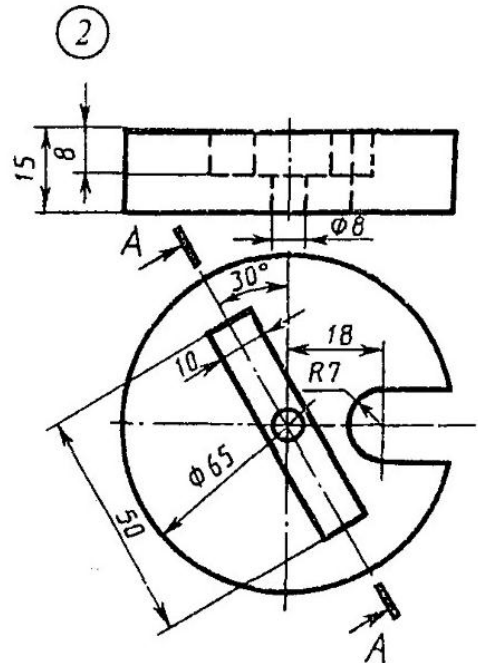

Диск

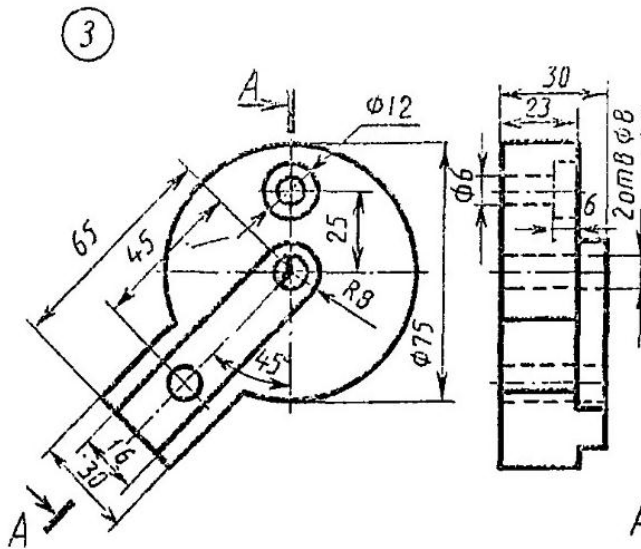

Пластинка

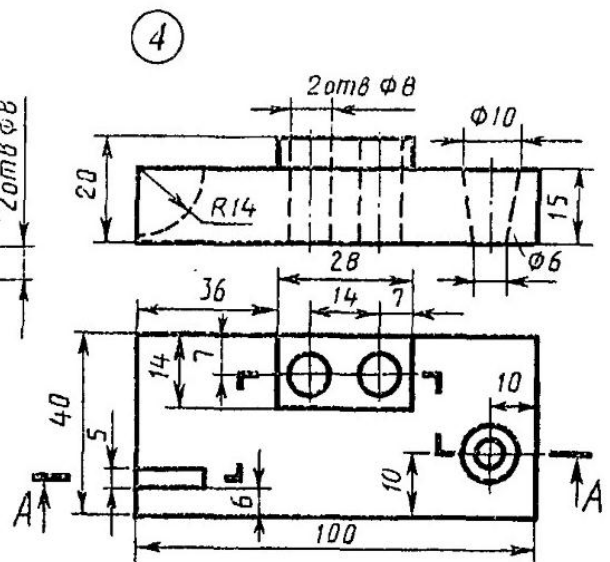

Плита

Вариант 3

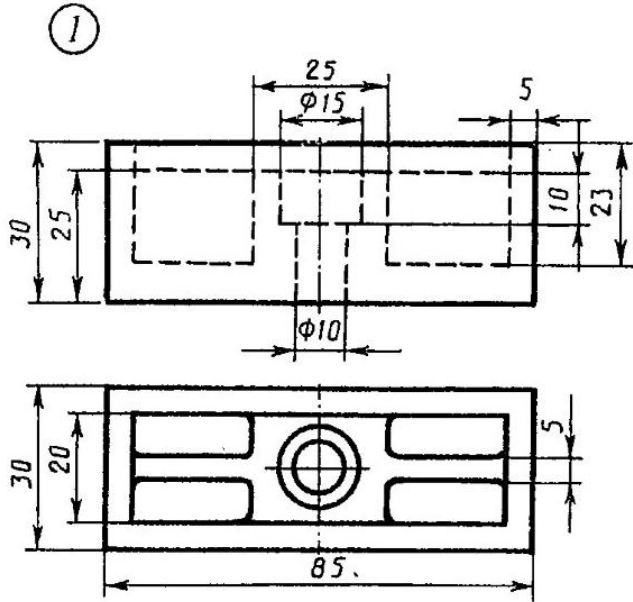

Опора

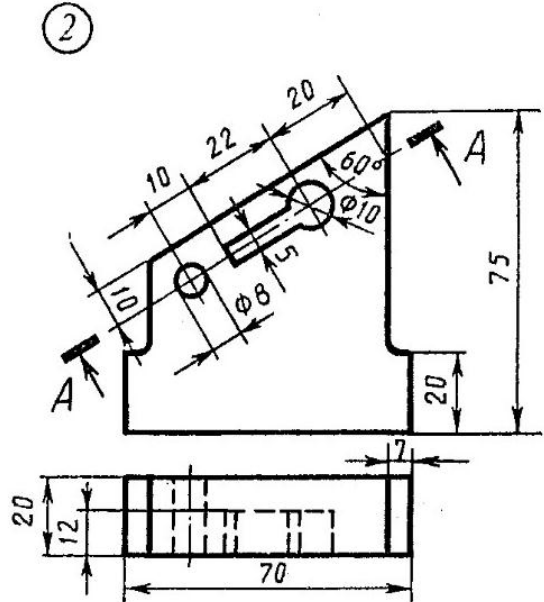

Стойка

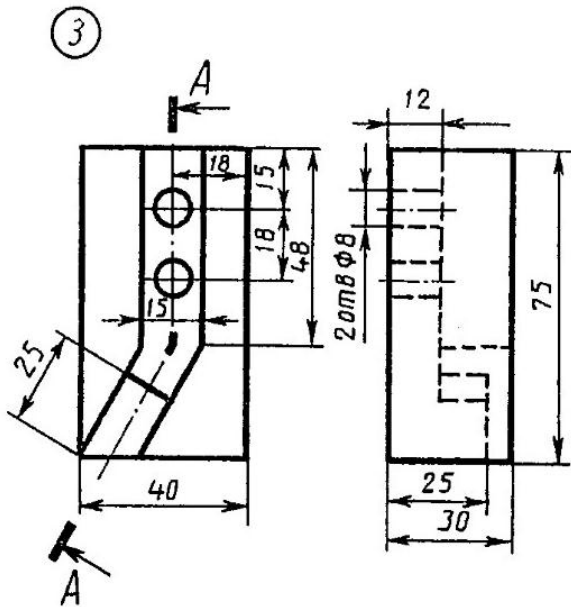

Угольник

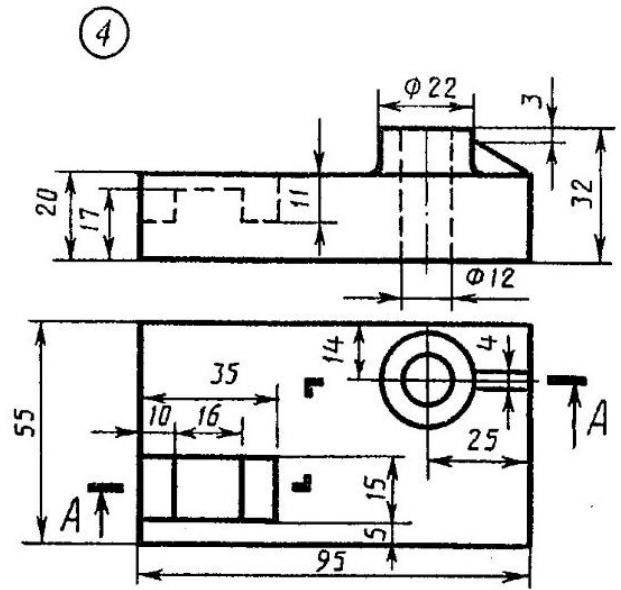

Плита

Вариант 4

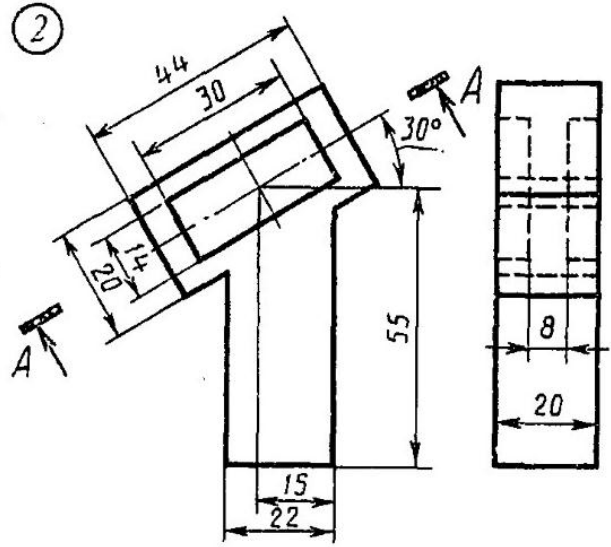
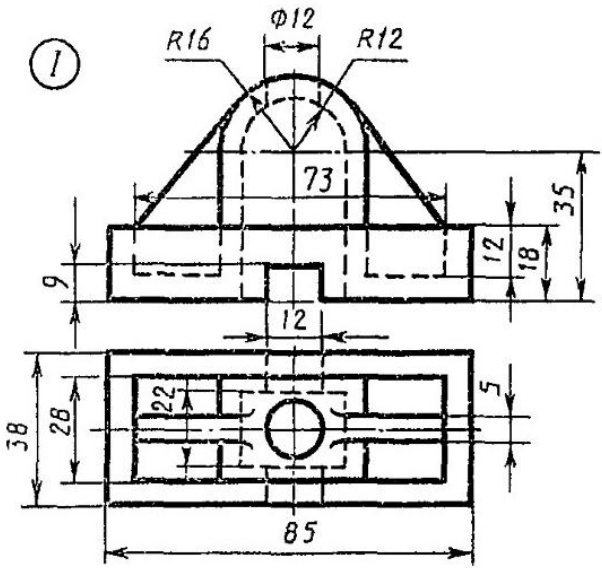

Стойка

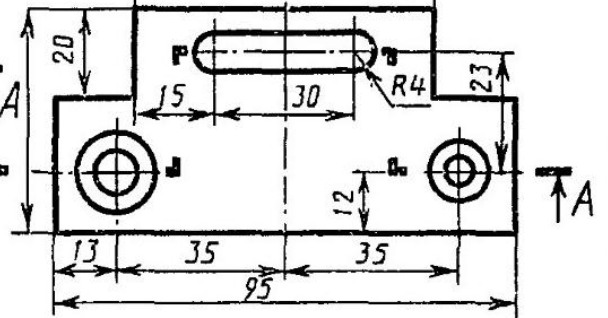
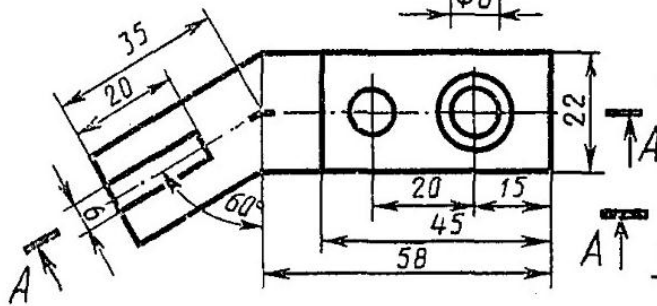
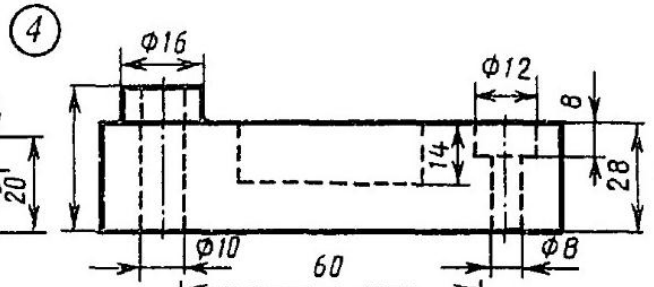
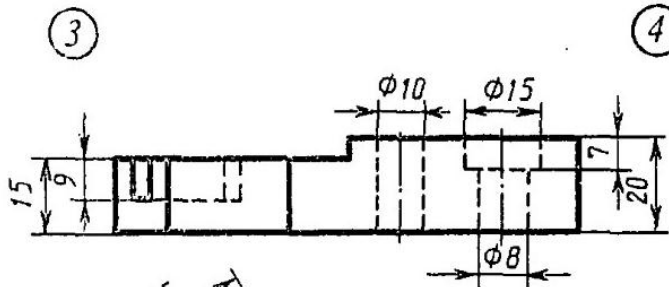

Скоба

Плата

Вариант 5

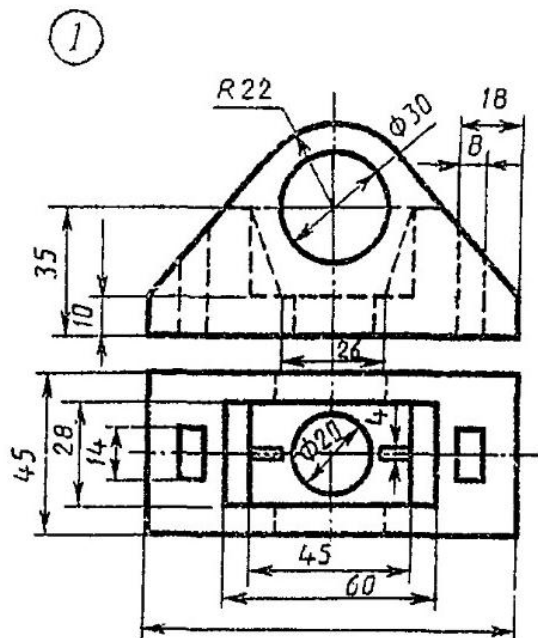

Крышка

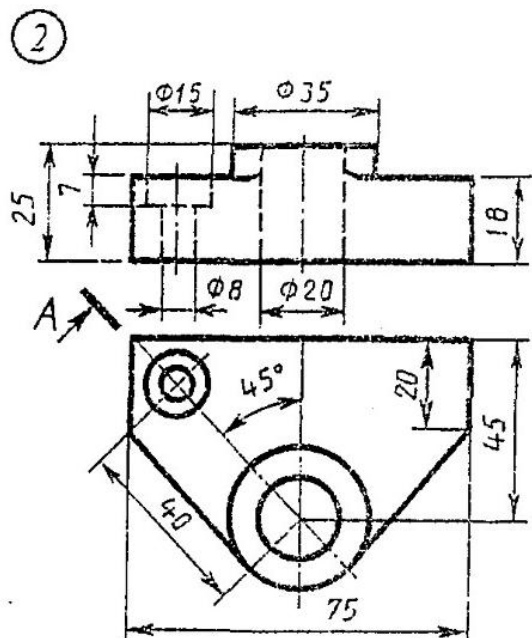

Планка

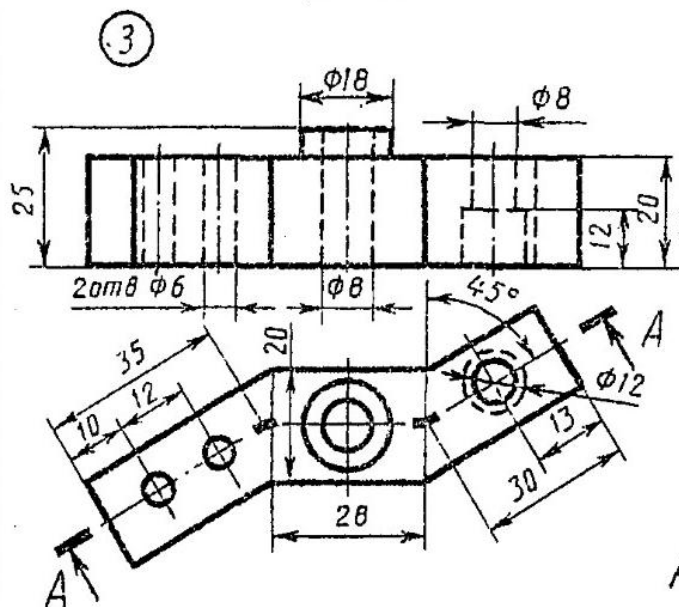

Змеевик

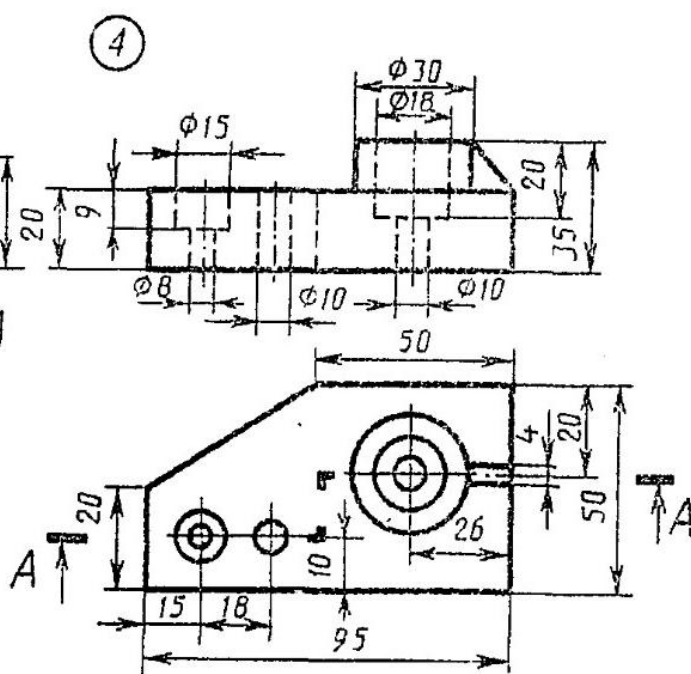

Плита

Вариант 6

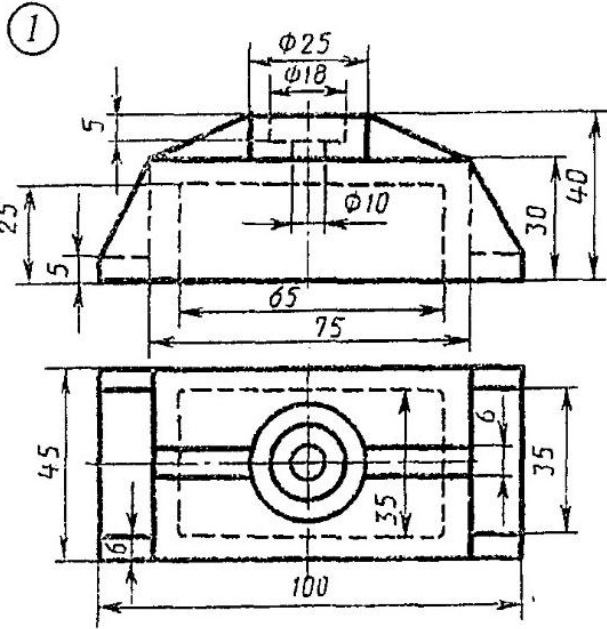

Крышка

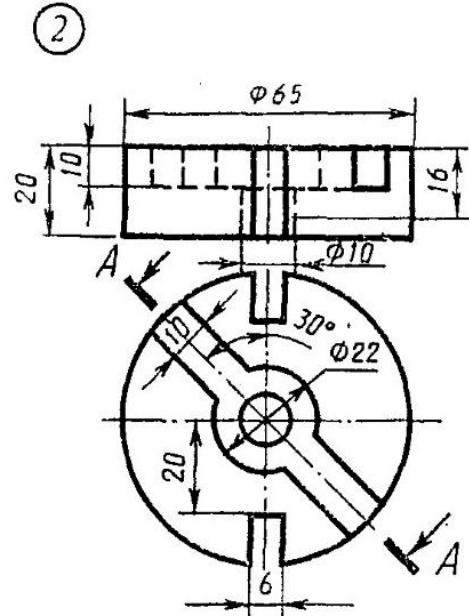

Диск

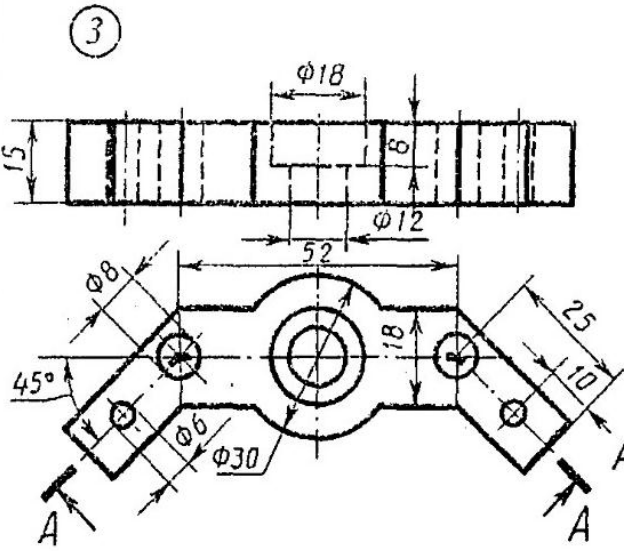

Скоба

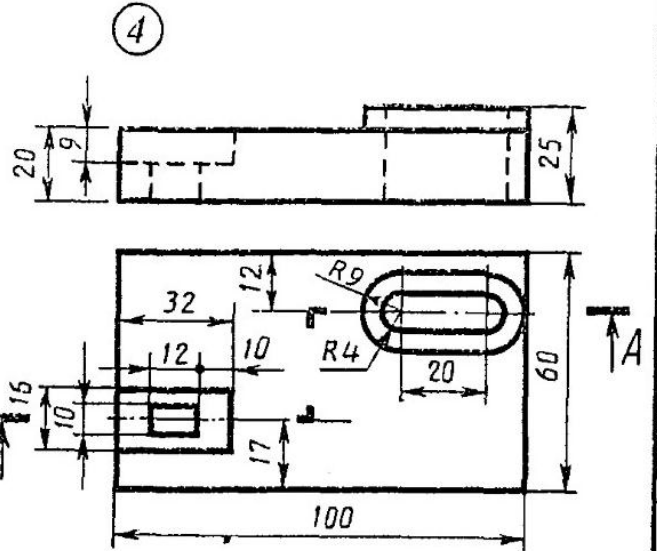

Плита

Вариант 7

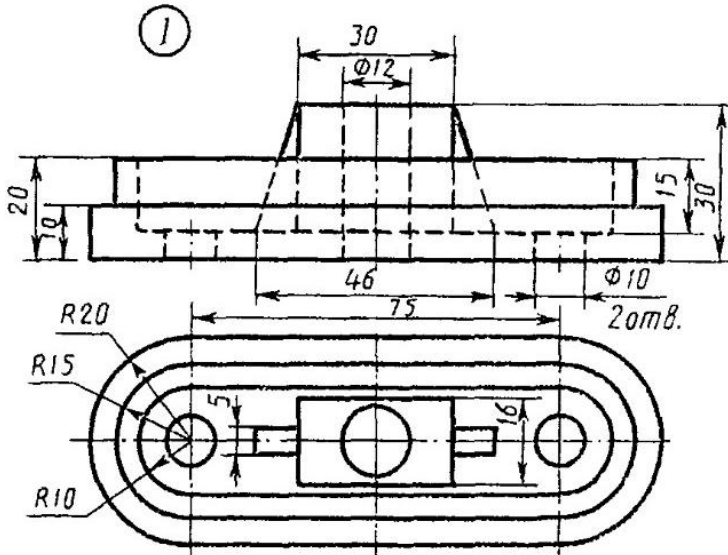

Опора

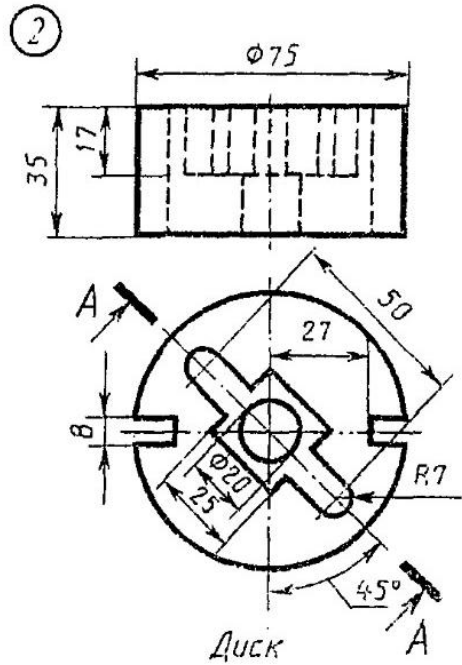

Диск

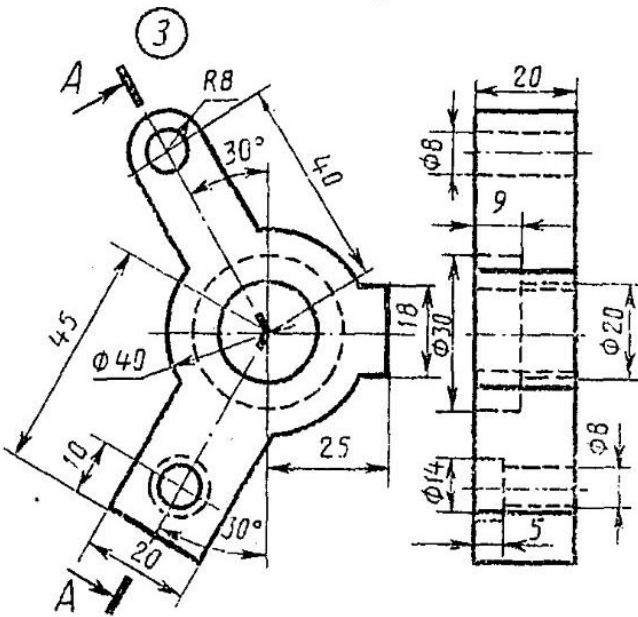

Угольник

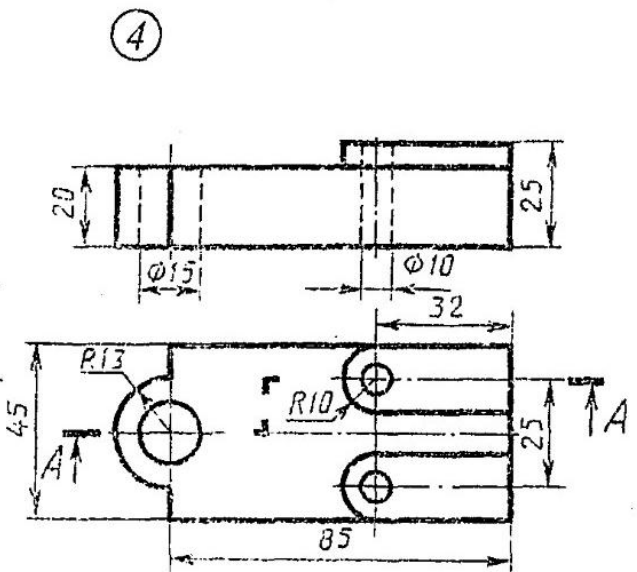

Вариант 8

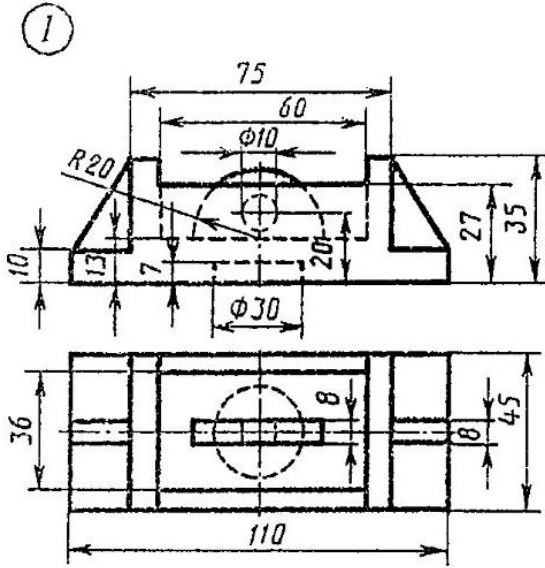

Корпус

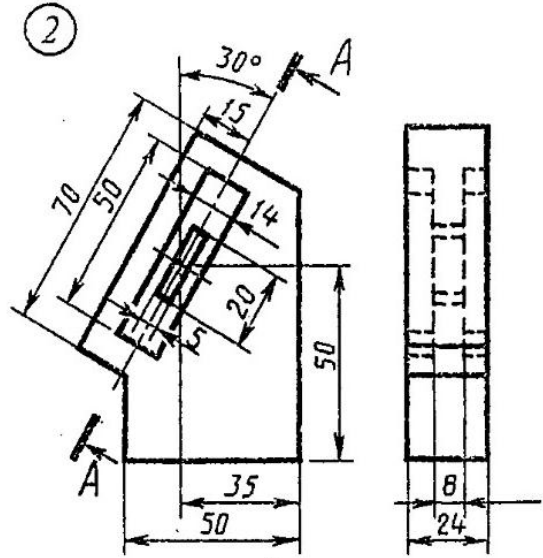

Планка

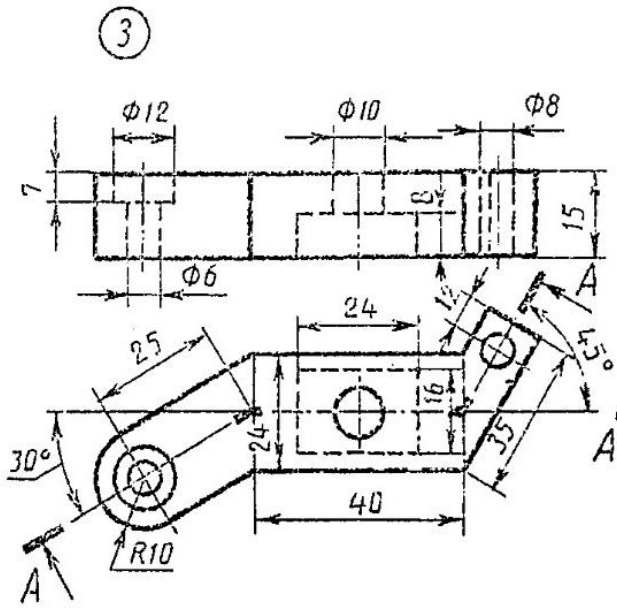

Пластинка

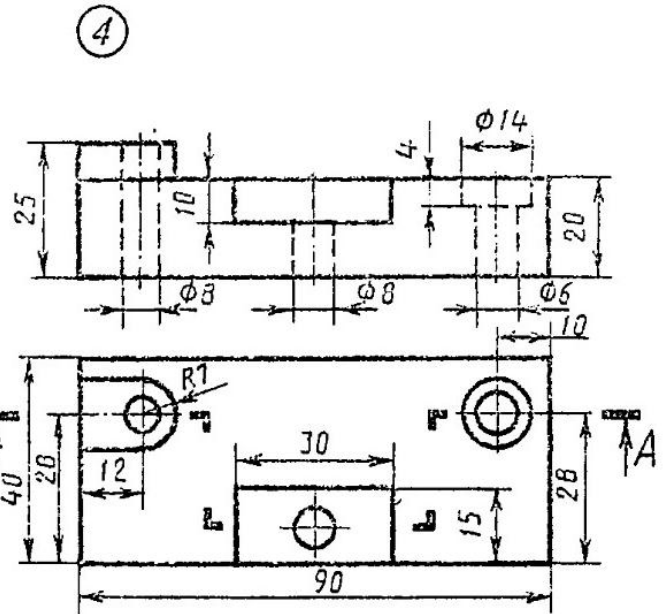

Плита

Вариант 9

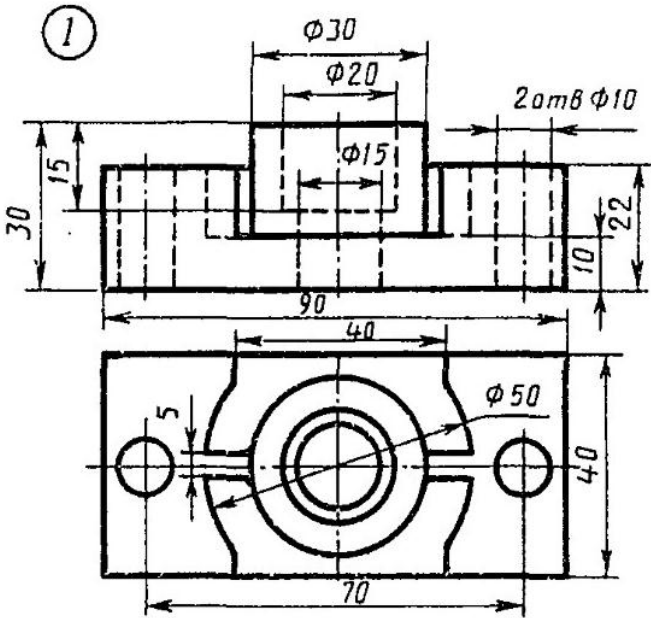

Корпус

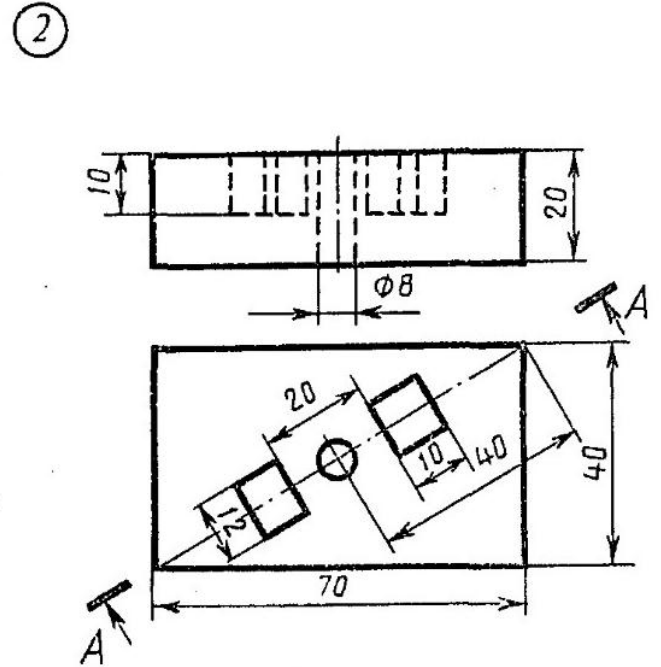

Плита

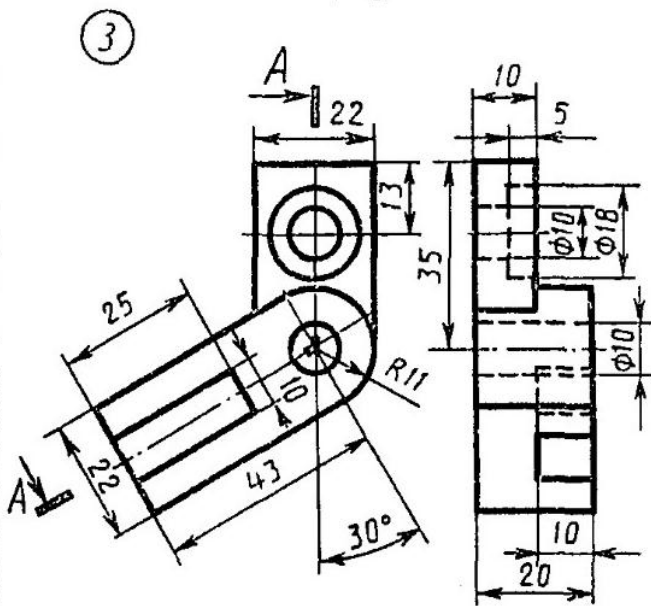

Угольник

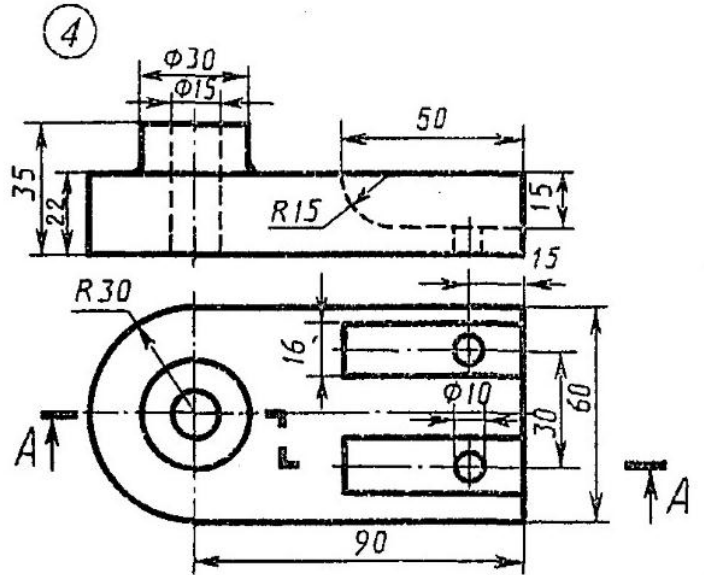

Опора

Вариант 10

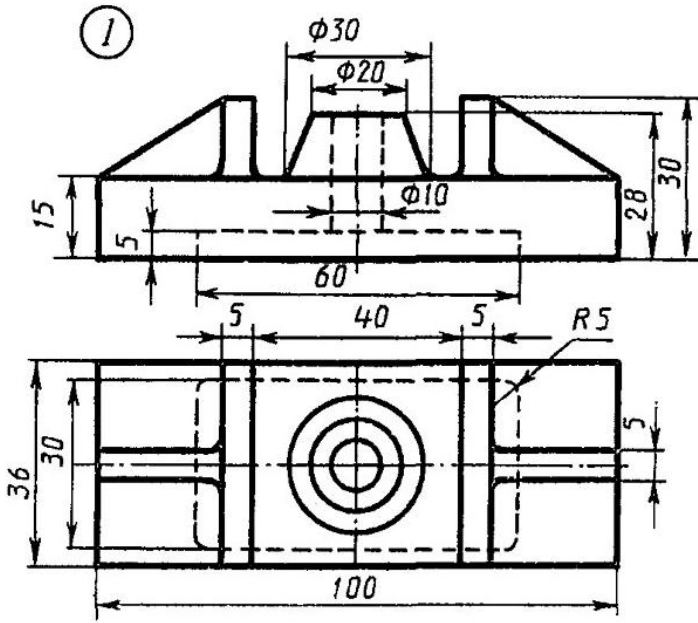

Опора

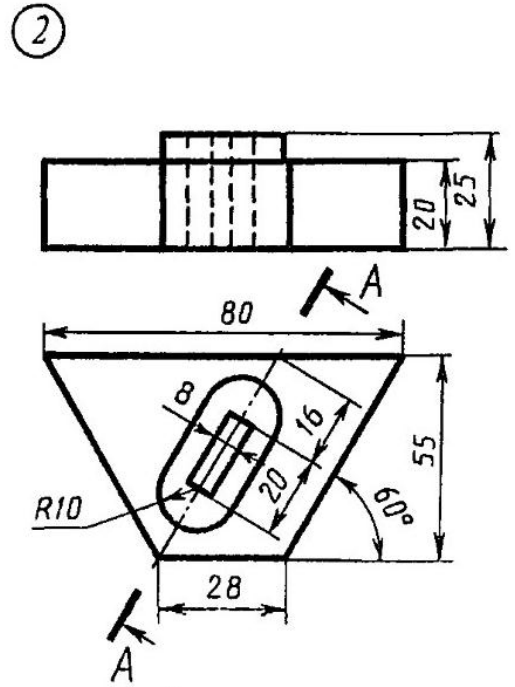

Пластина

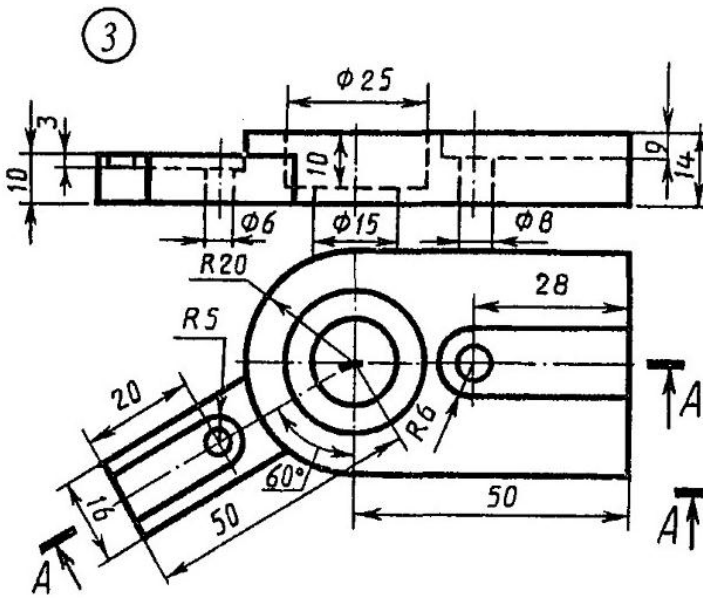

Замок

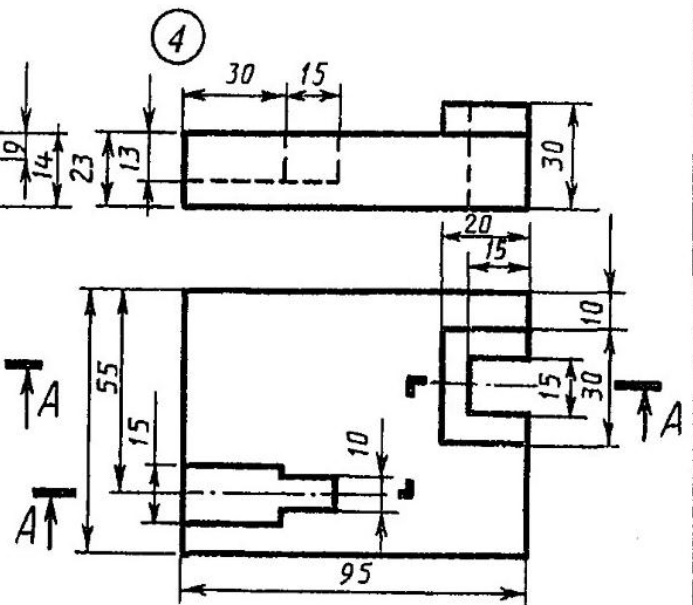

Плита

Вариант II

1

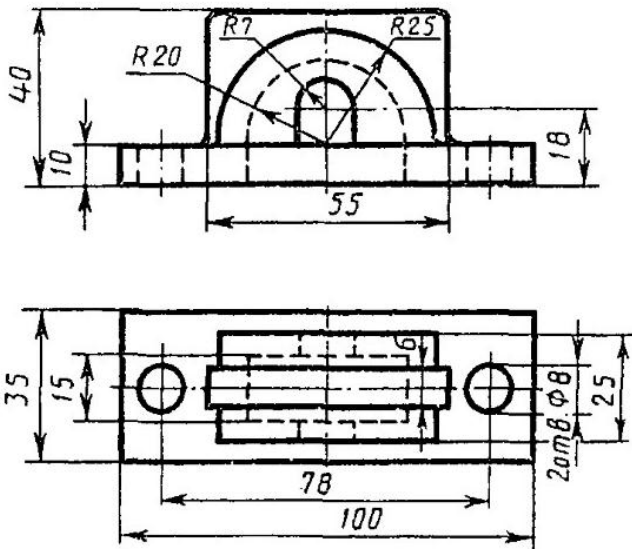

Крышка

2

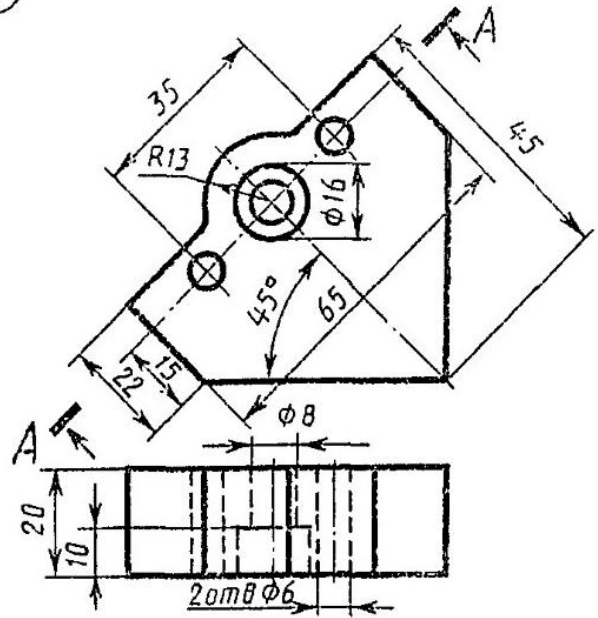

Пластина

3

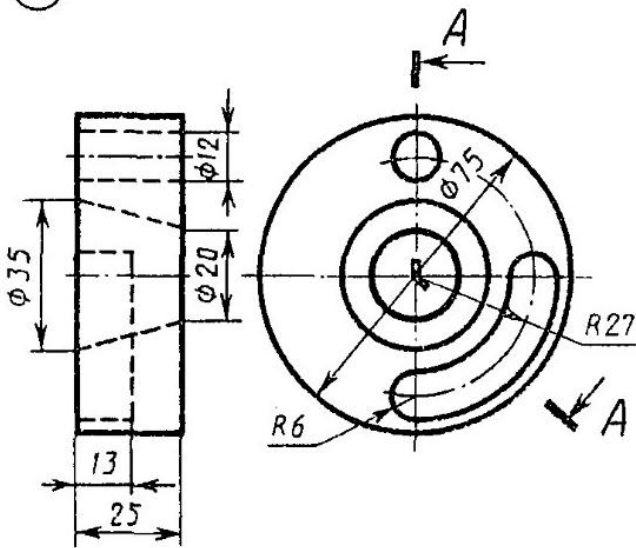

Замок

4

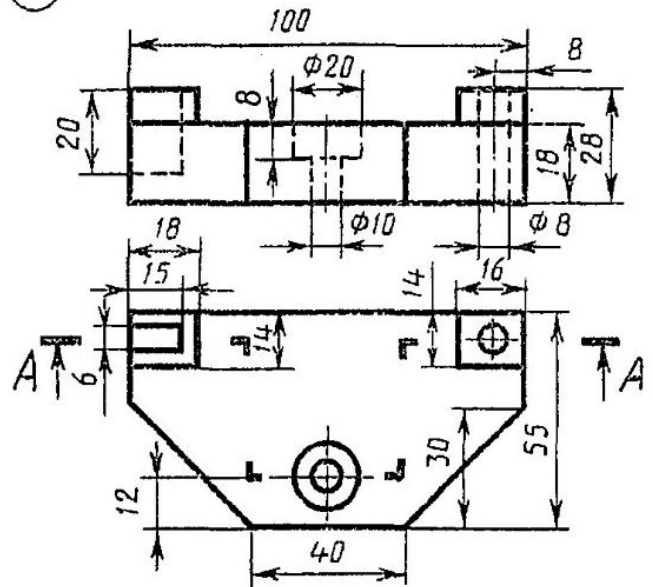

Корпус

Вариант 12

1

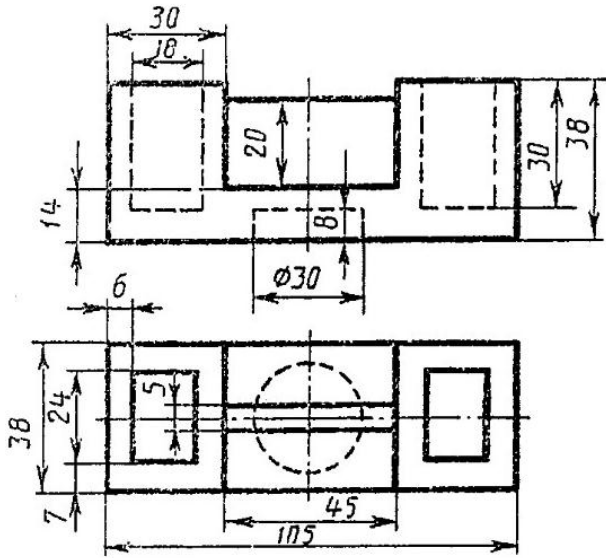

Опора

2

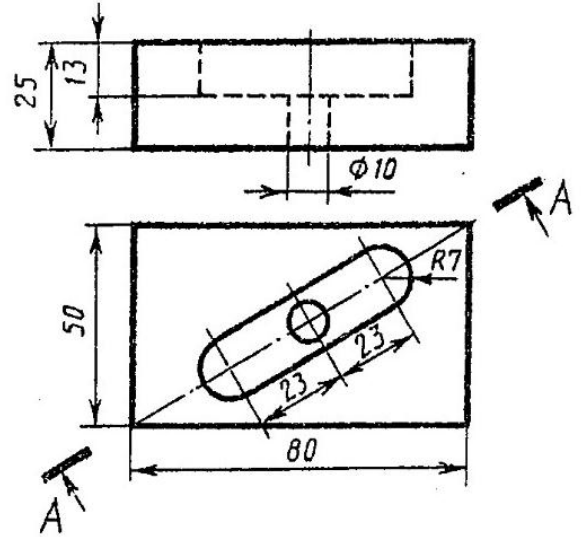

Плита

3

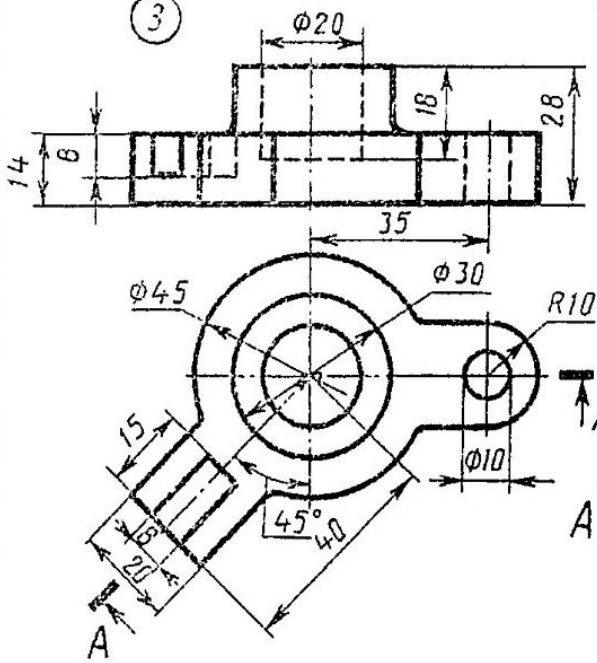

Замок

4

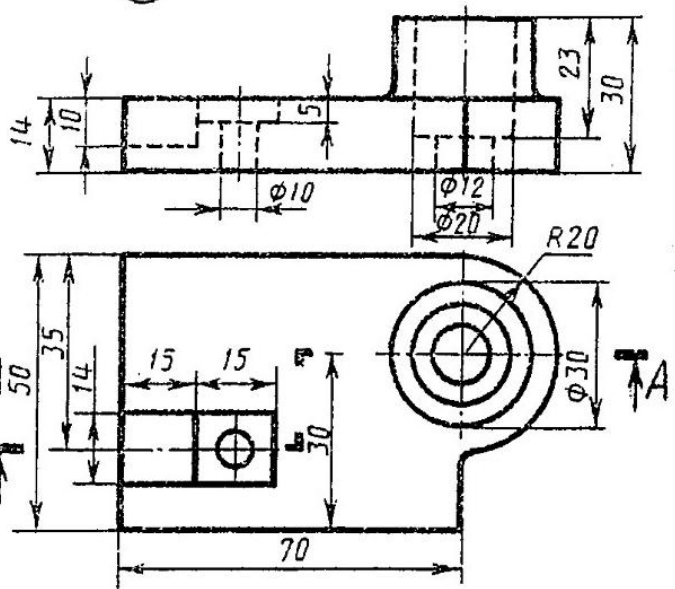

Корпус

Вариант 13

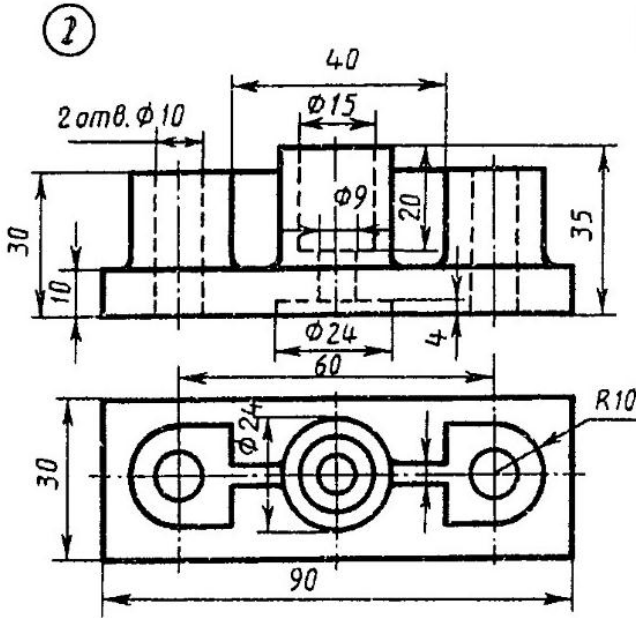

Корпус

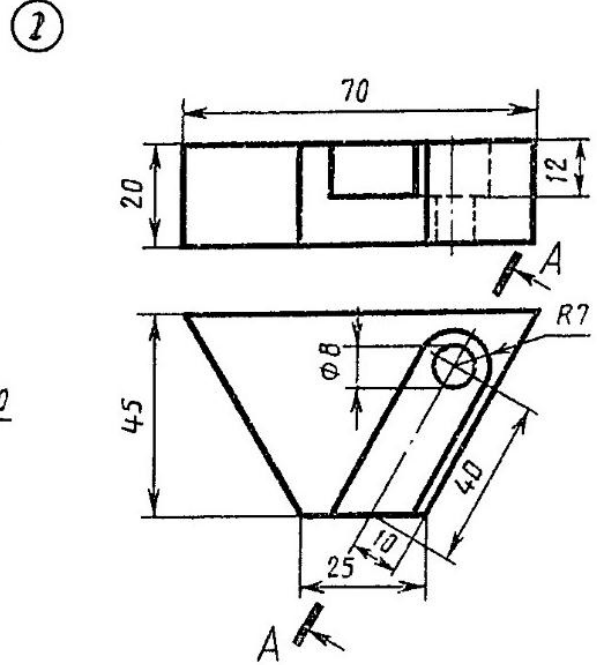

Пластина

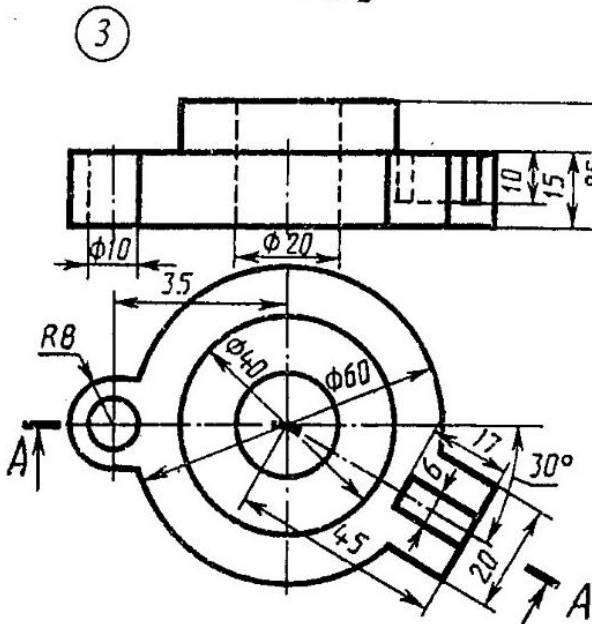

Диск

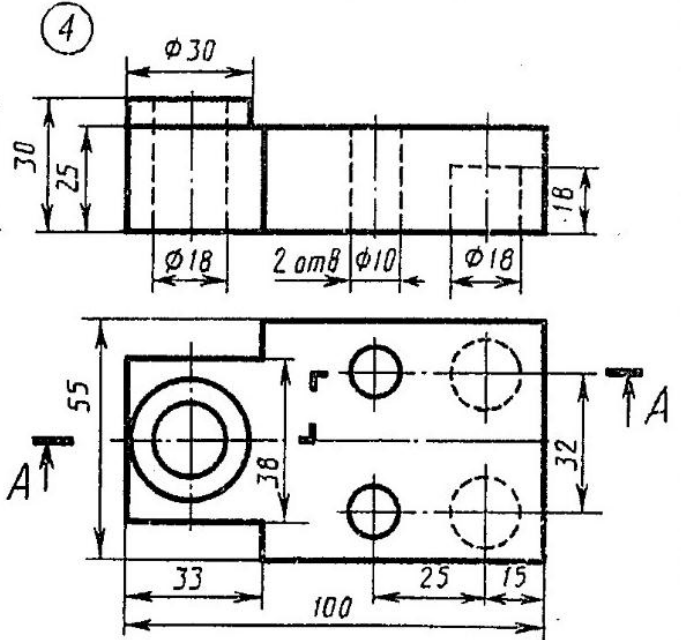

Плита

Вариант 14

1

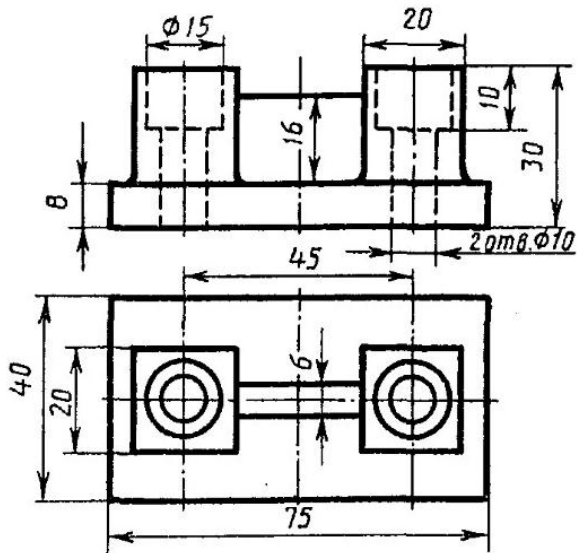

Опора

2

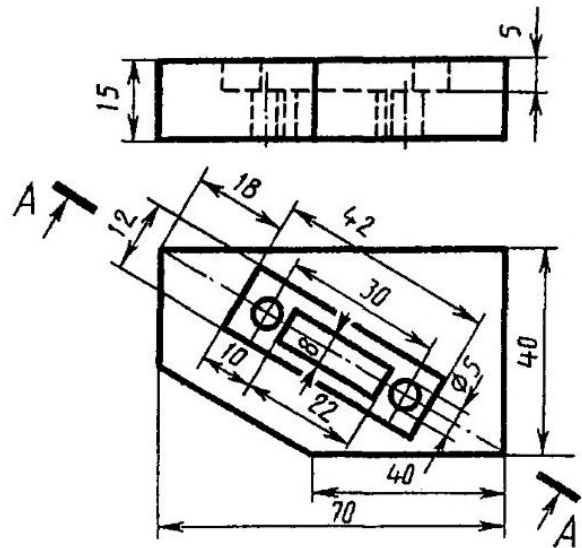

Плита

3

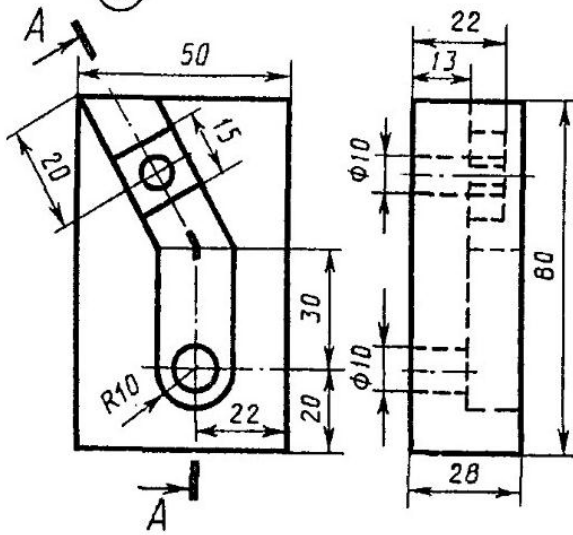

Угольник

4

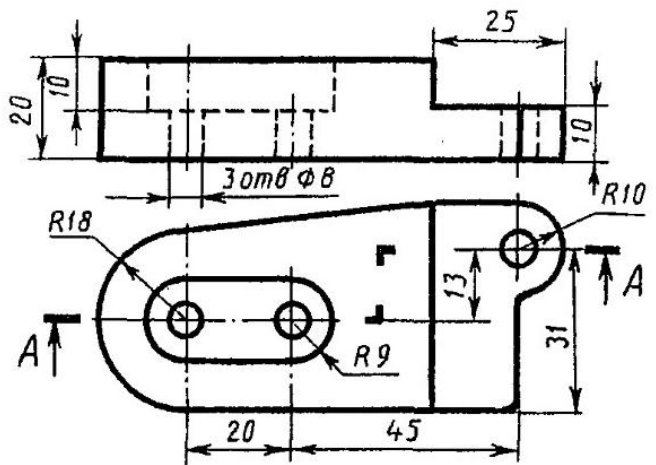

Плита

Вариант 15

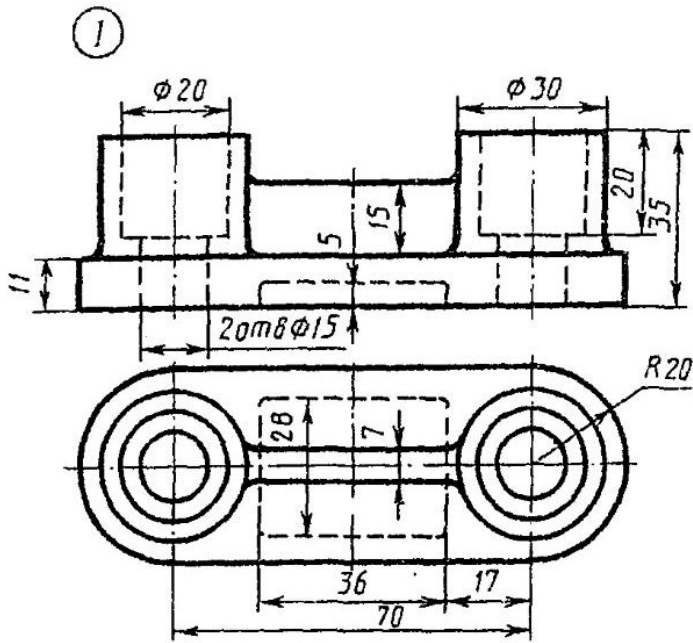

Опора

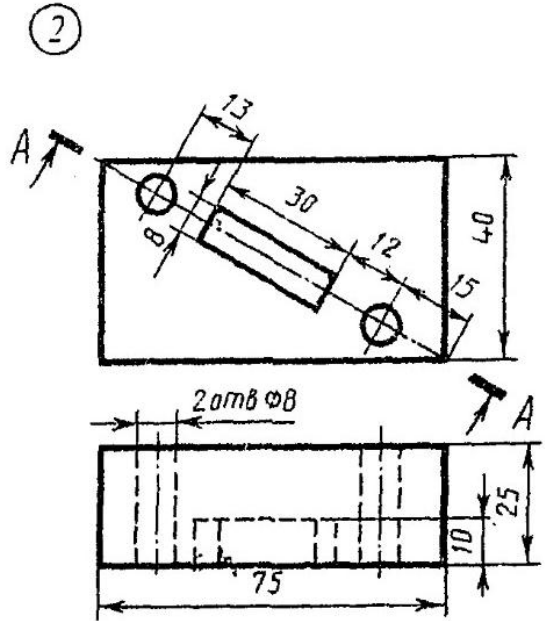

Плита

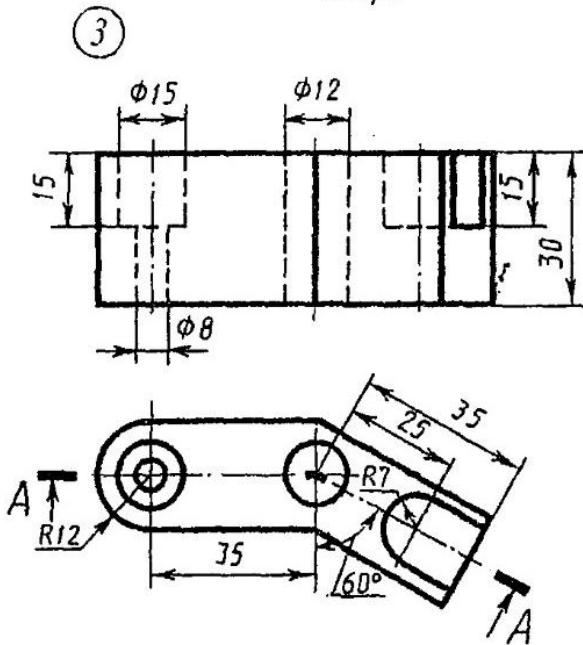

Скоба

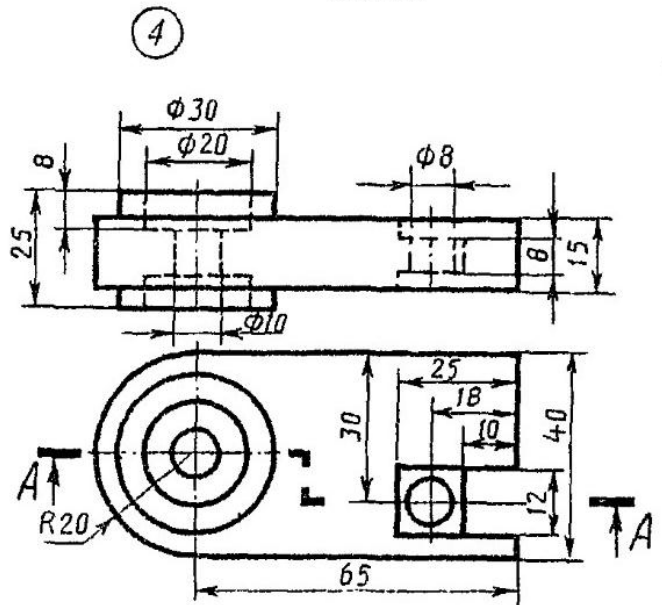

Серьга

Вариант 16

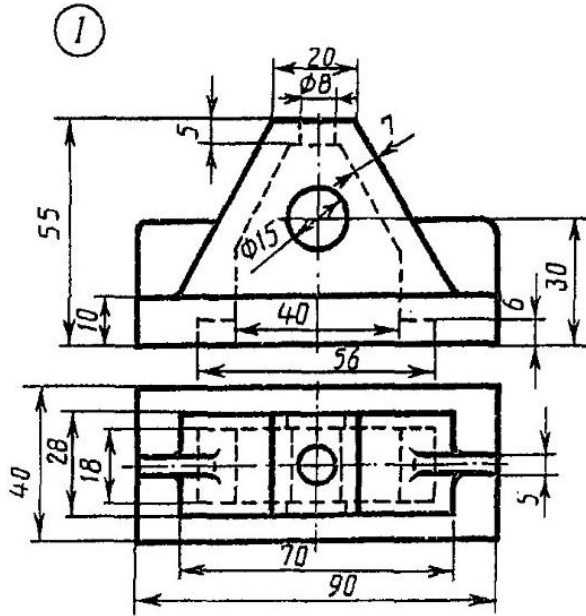

Стойка

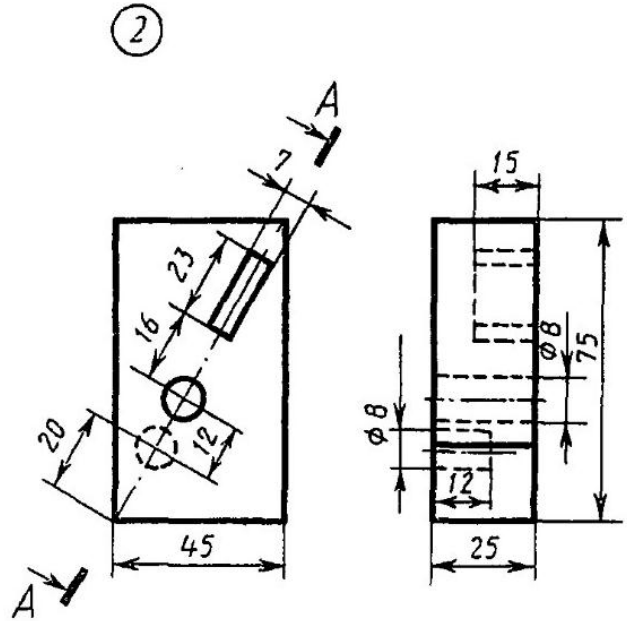

Плита

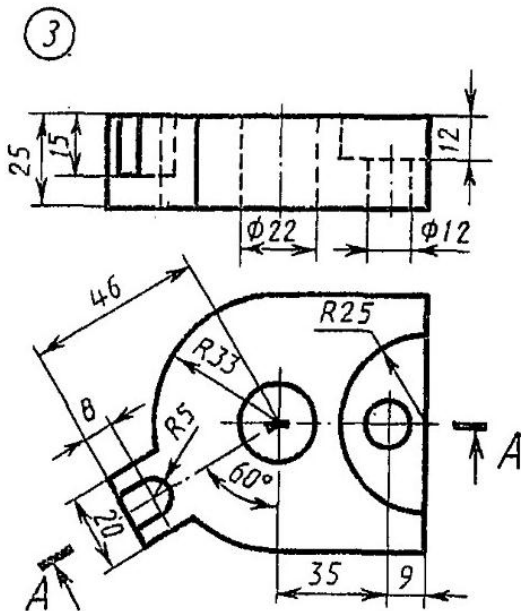

Основа

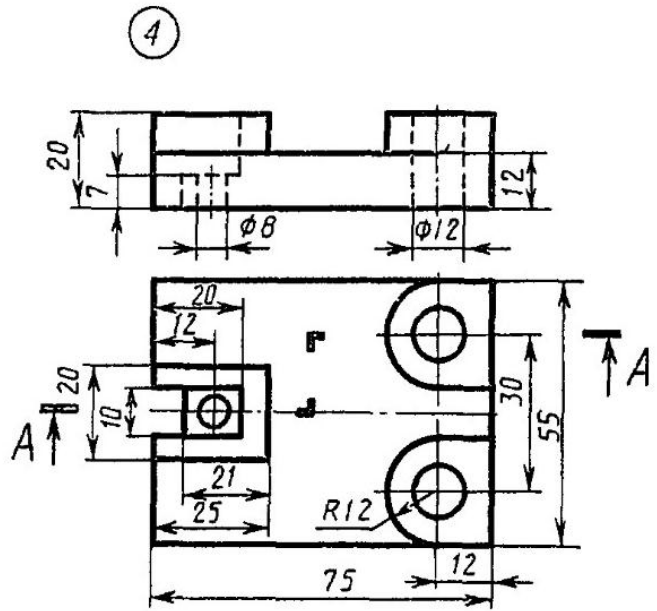

Опора

Вариант 17

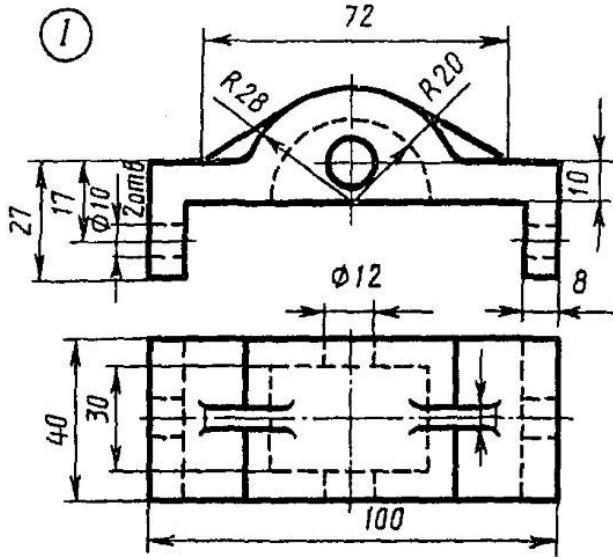

Корпус

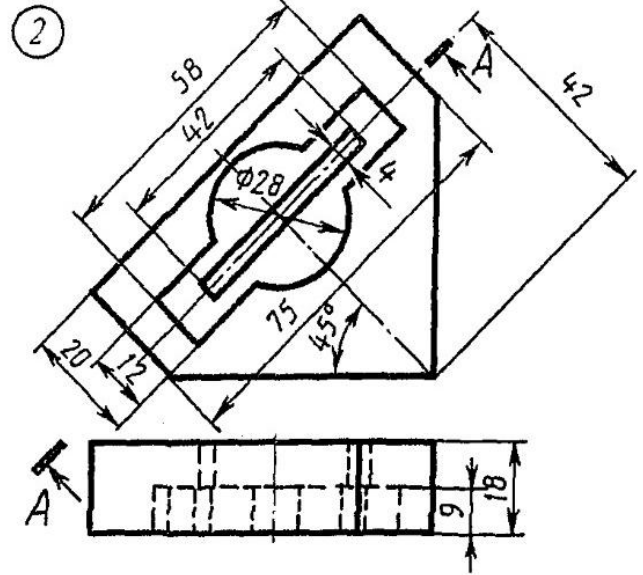

Пластина

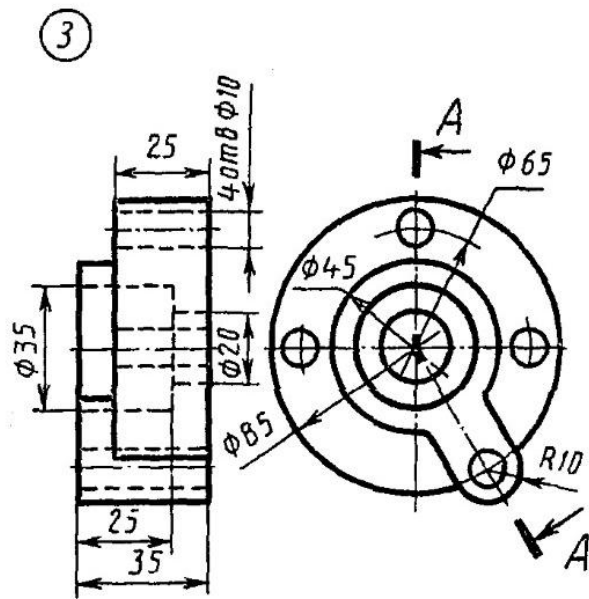

Диск

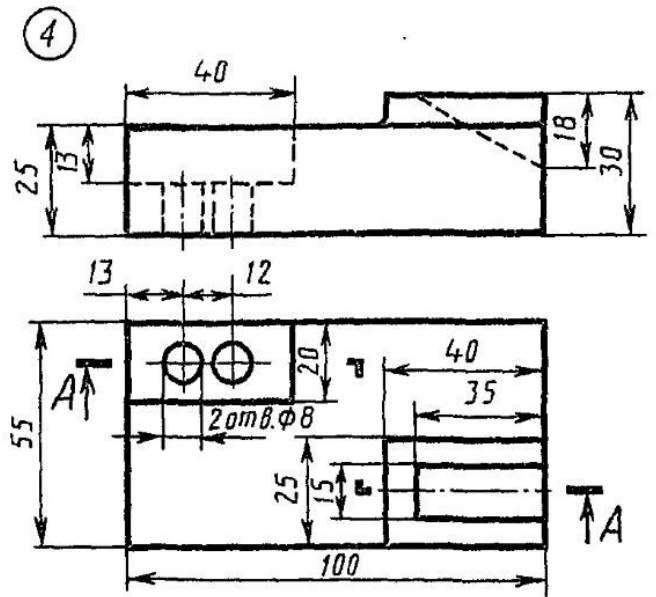

Плита

Вариант 18

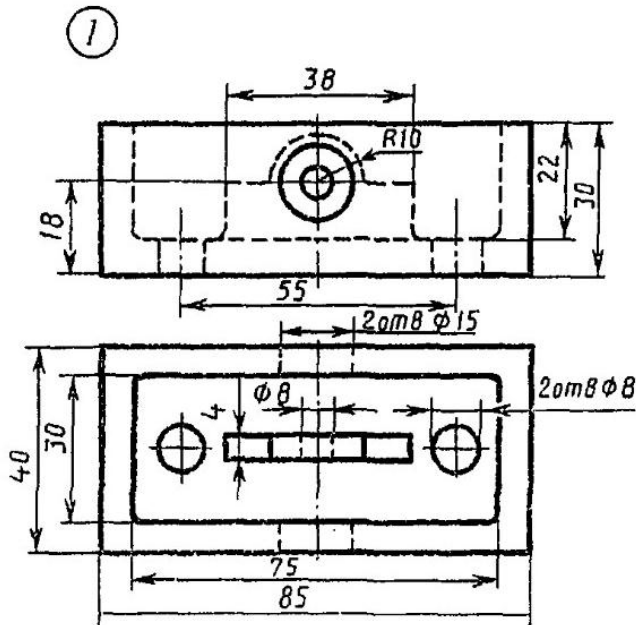

Коробка

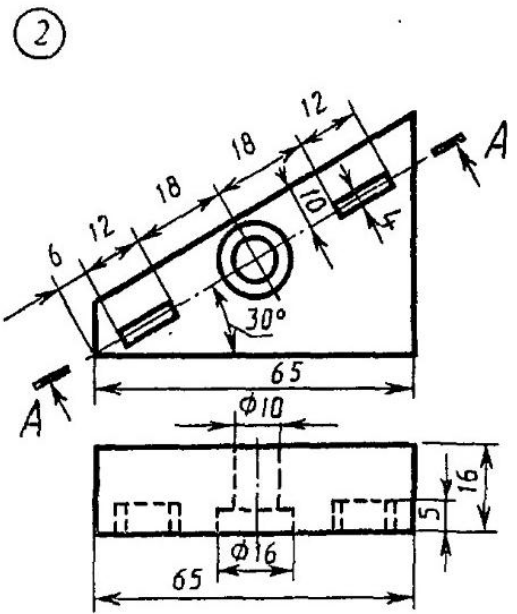

Пластина

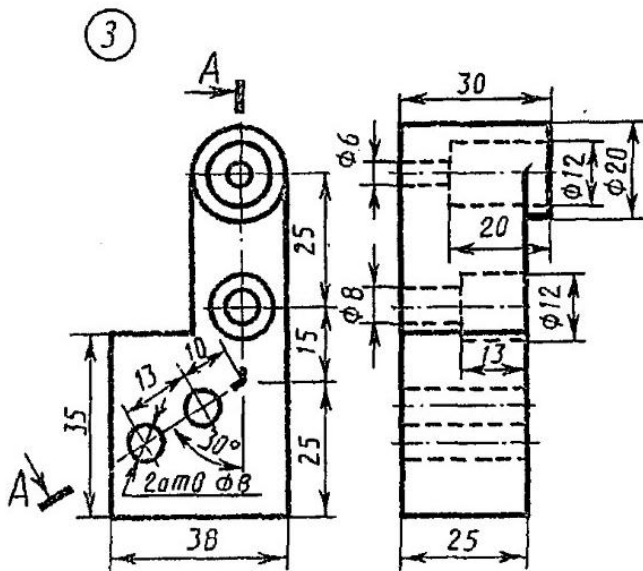

Кронштейн

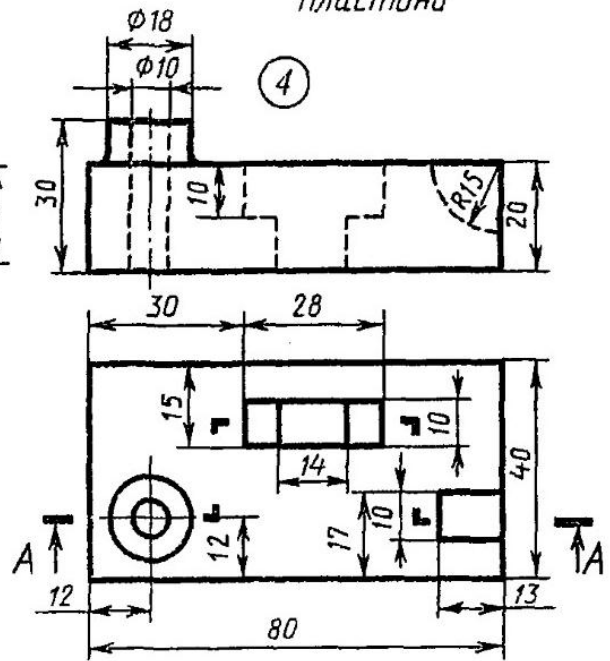

Корпус

Вариант 19

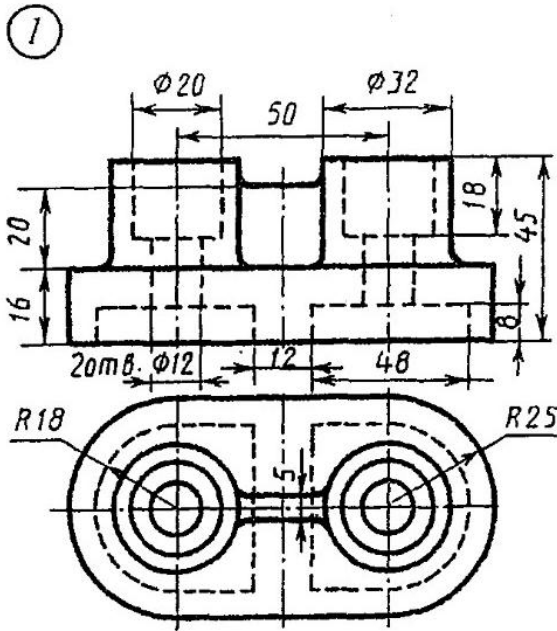

Опора

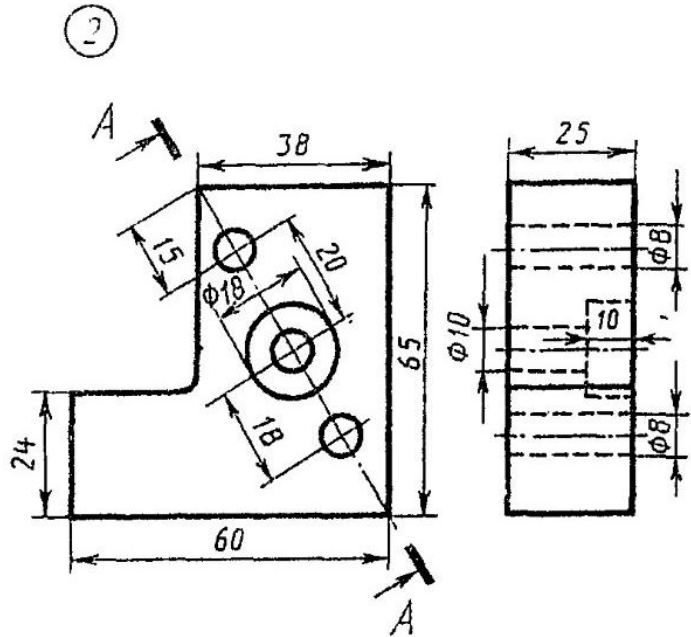

Стойка

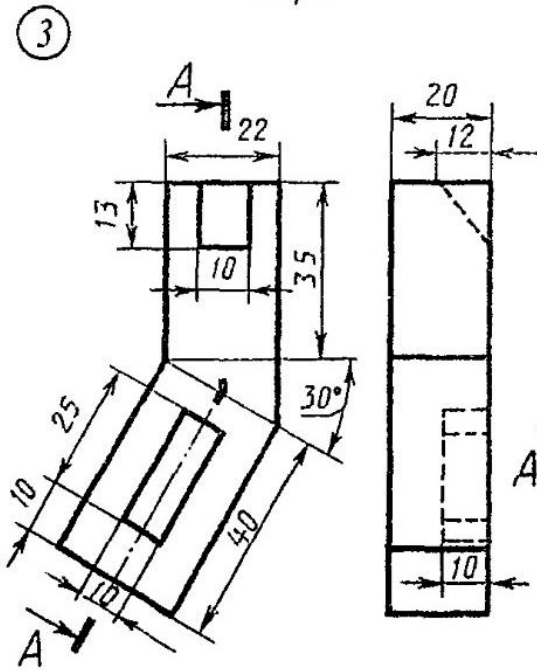

Пластина

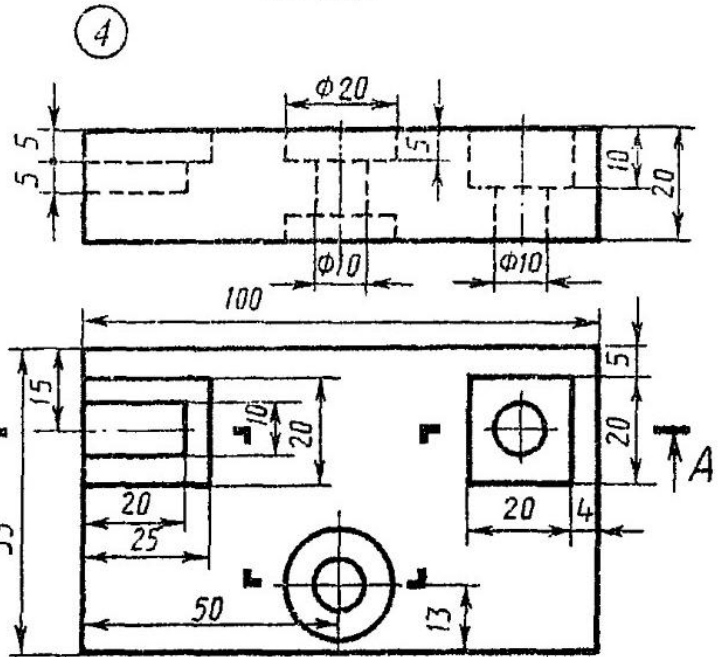

Плита

Вариант 21

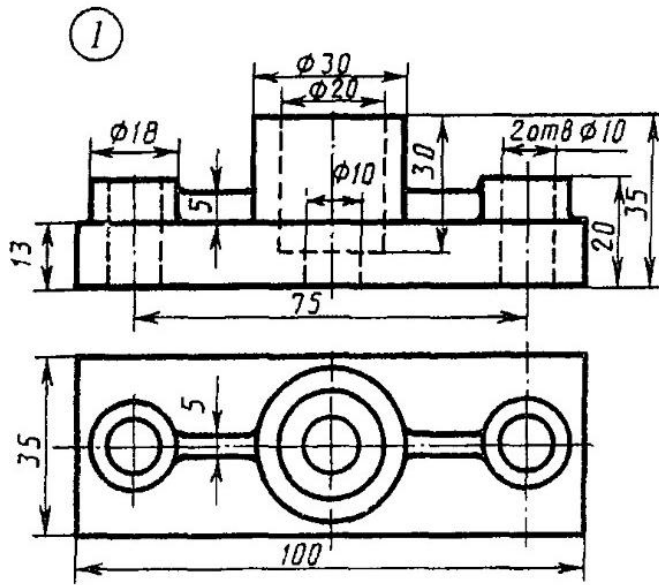

Опора

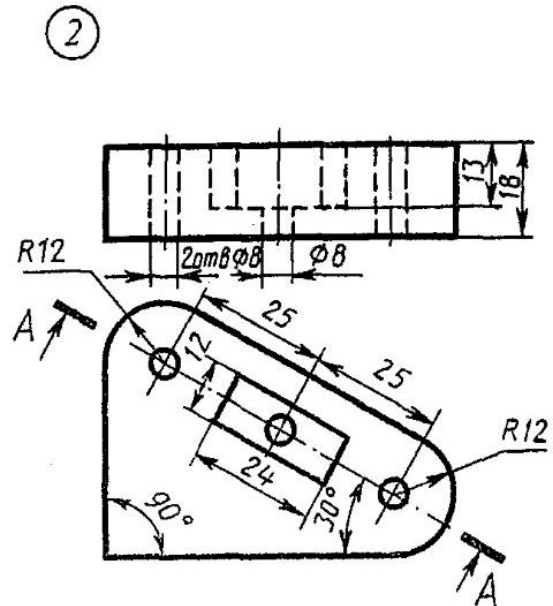

Пластина

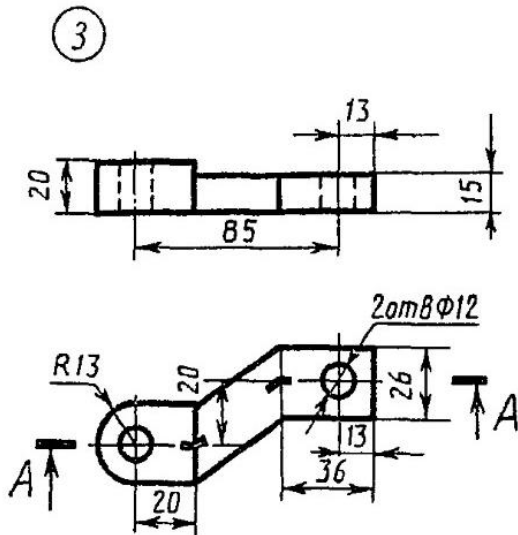

Шкода

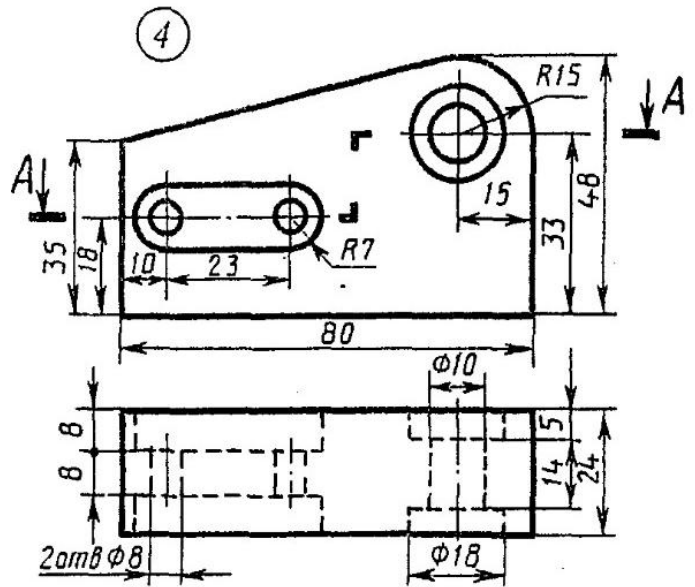

Корпус

Вариант 22

1

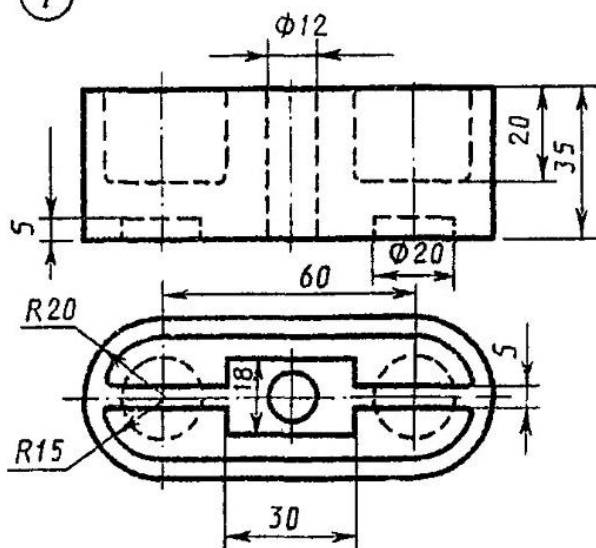

Коробка

2

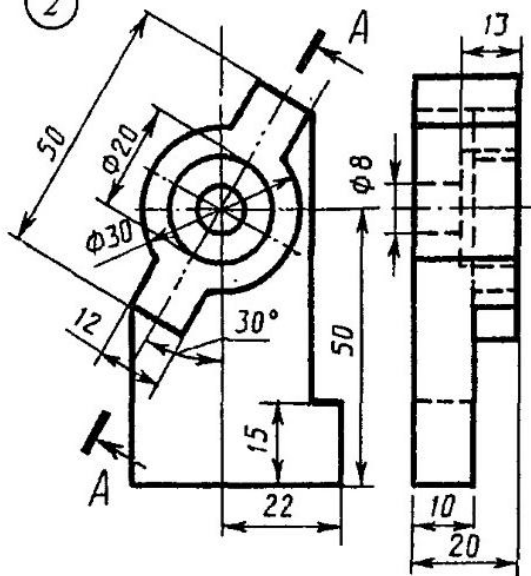

Стойка

3

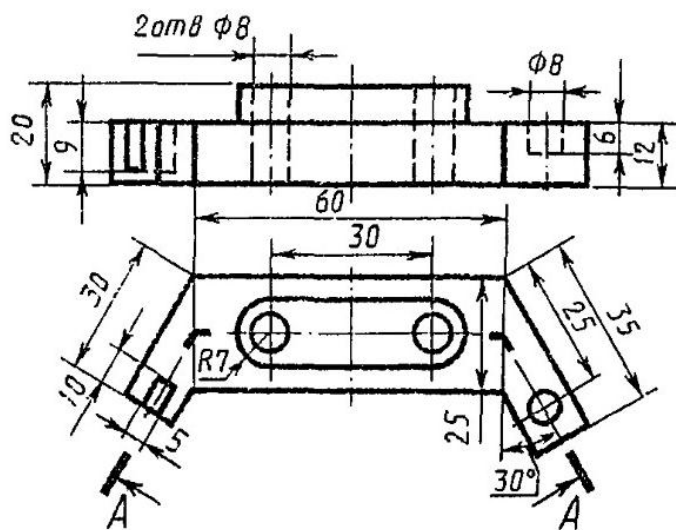

Скоба

4

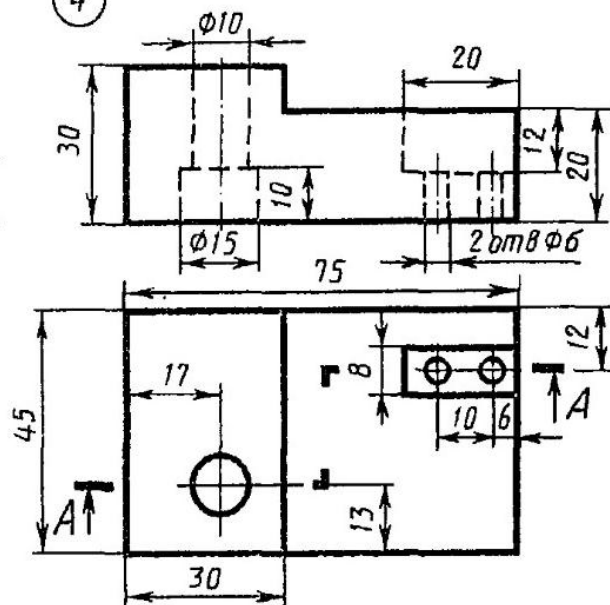

Серьга

Вариант 23

1

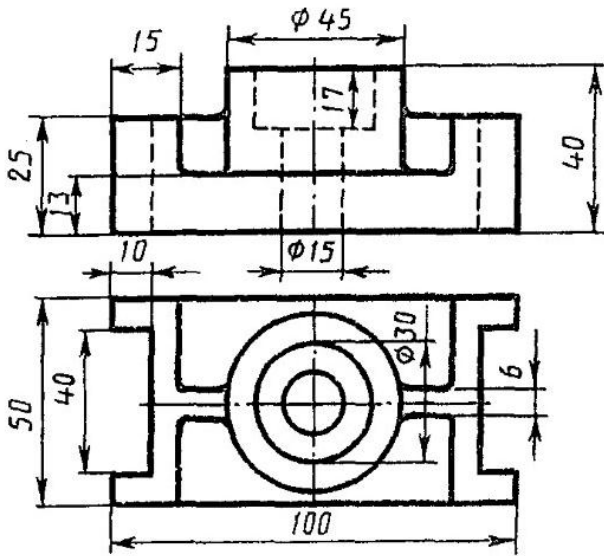

Упор

2

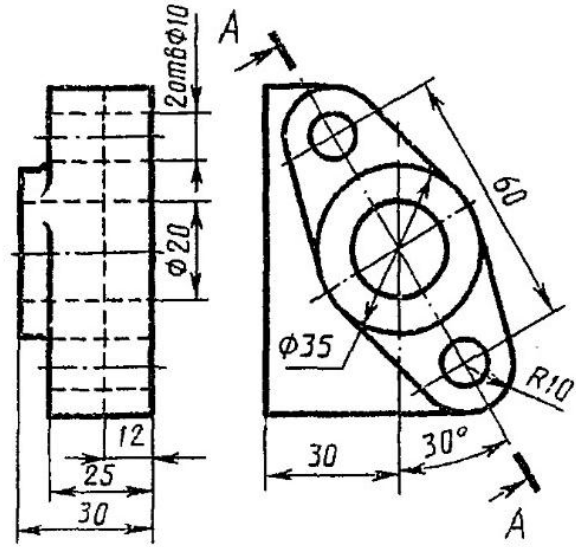

Фланец

3

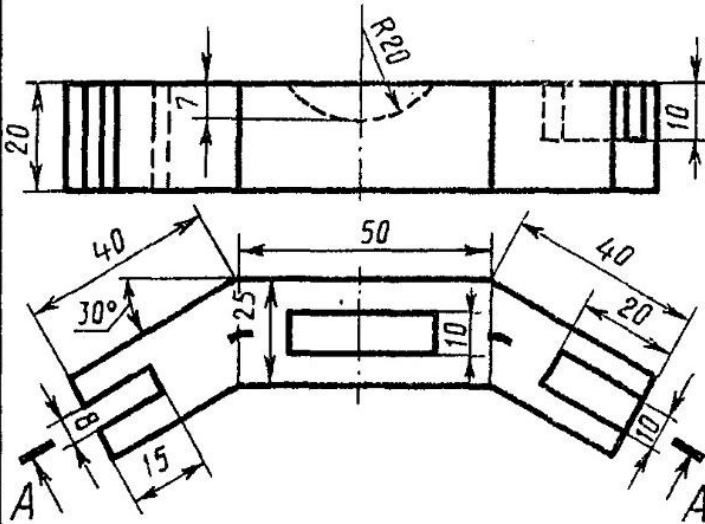

Скоба

4

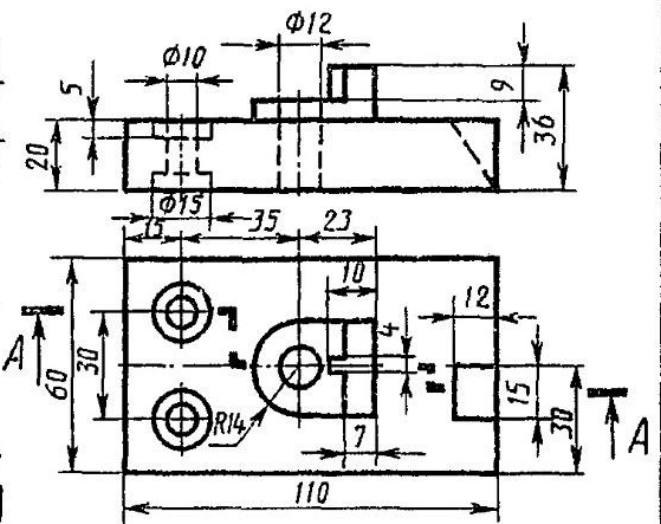

Плита

Вариант 24

1

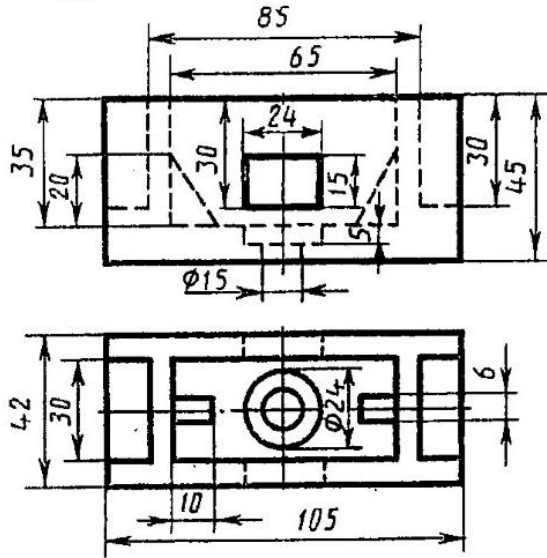

Коробка

2

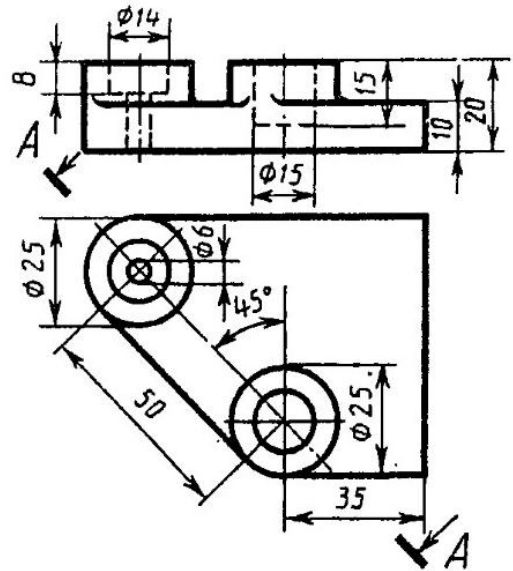

Плита

3

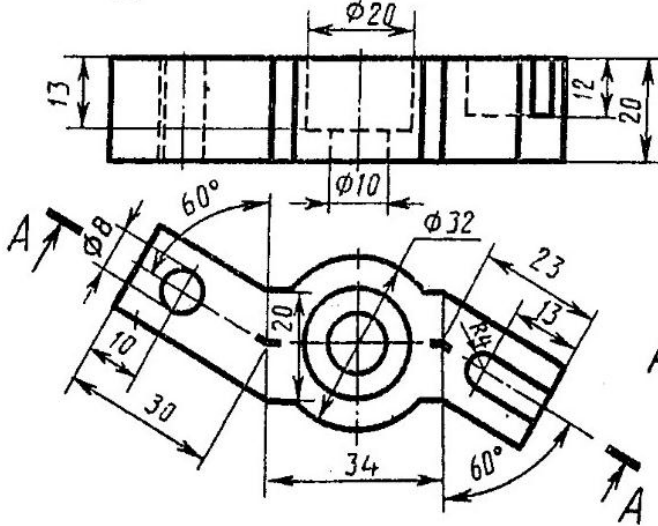

Скоба

4

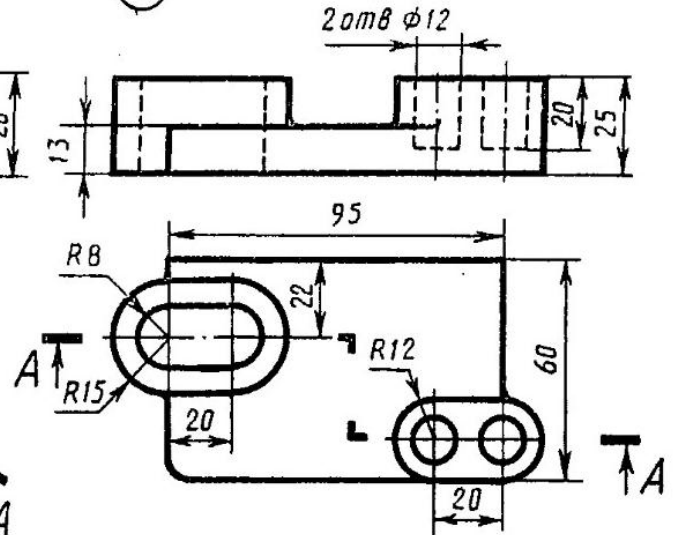

Плита

Вариант 25

1

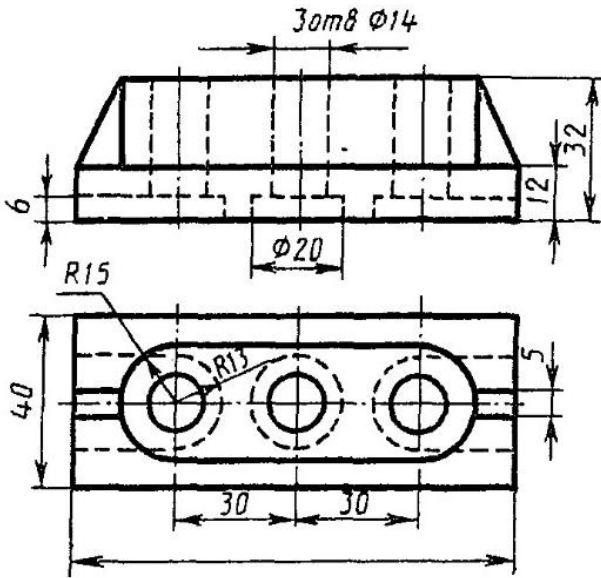

Опора

2

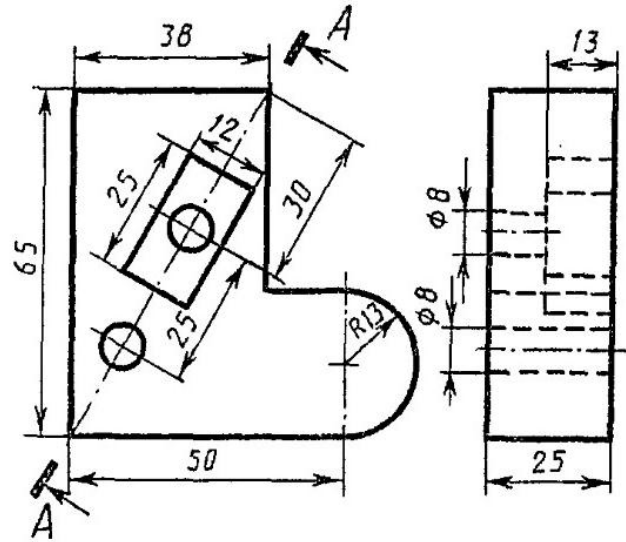

3

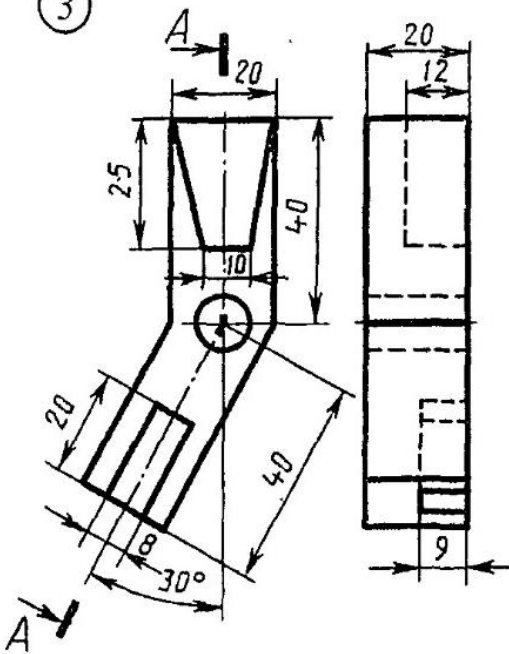

Угольник

4

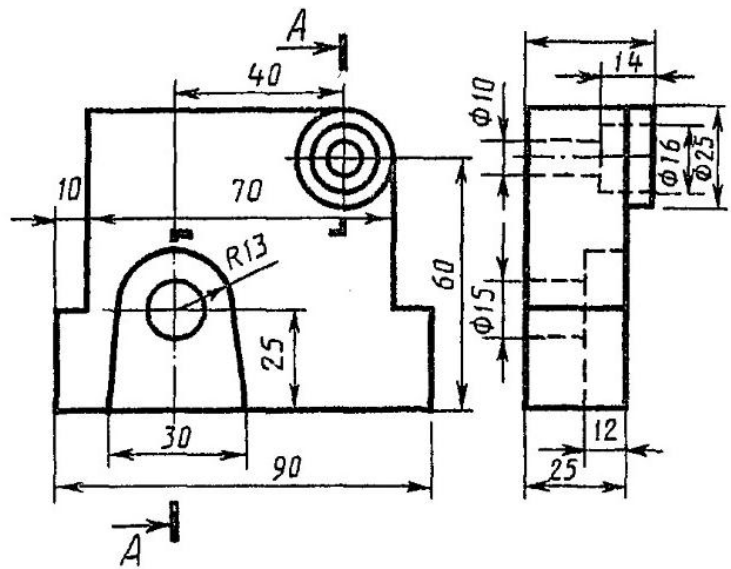

Стойка

Вариант 26

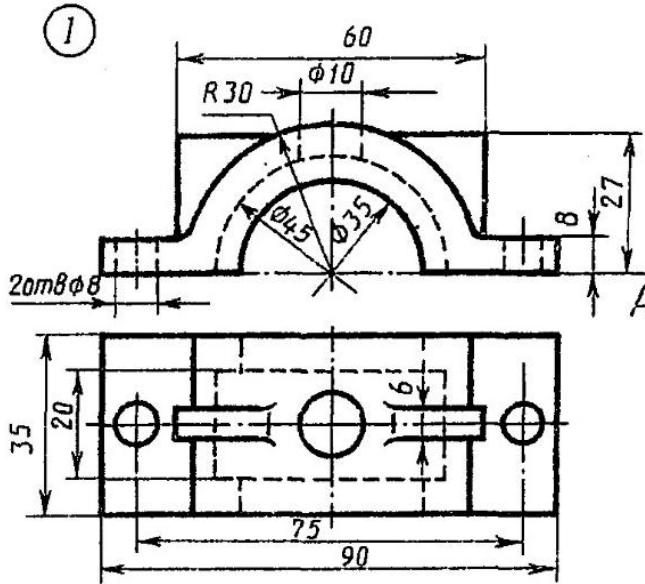

Крышка

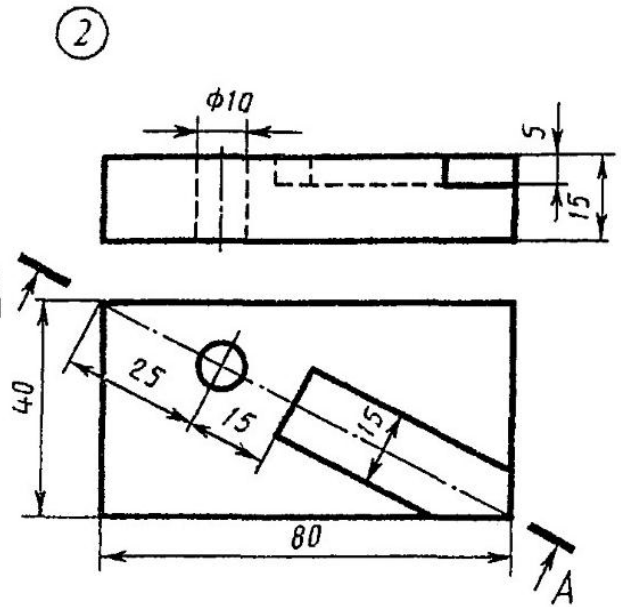

Плита

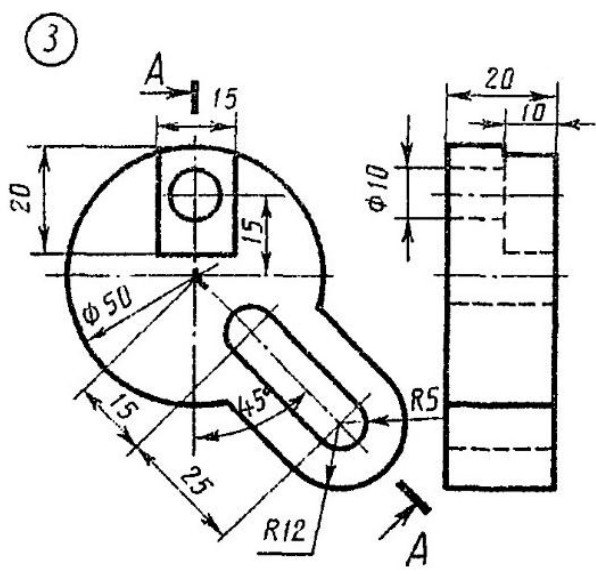

Диск

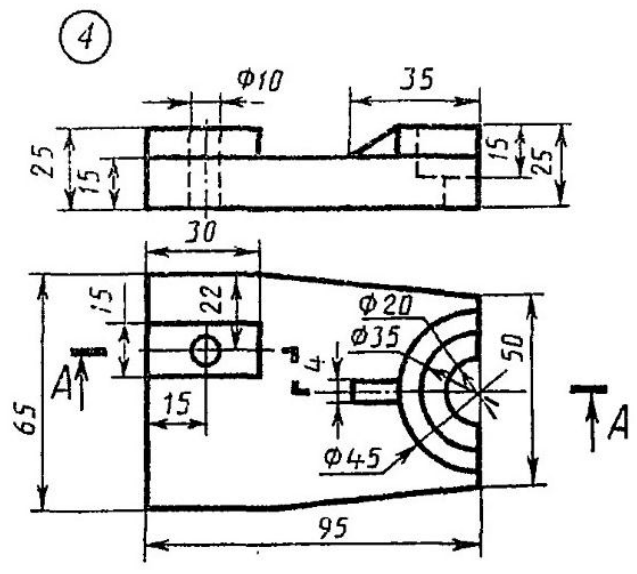

Опора

Вариант 28

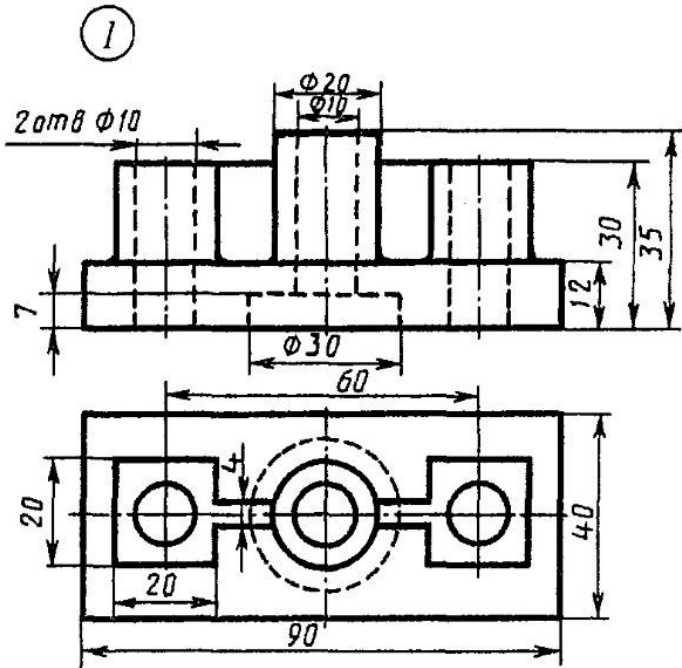

Опора

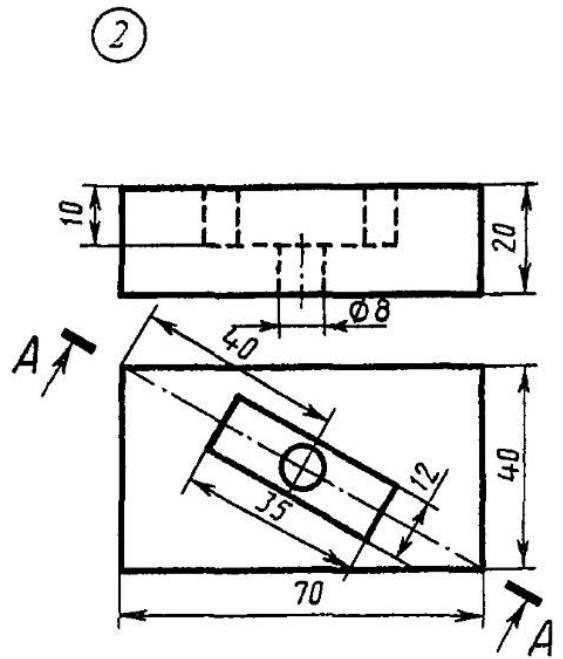

Плита

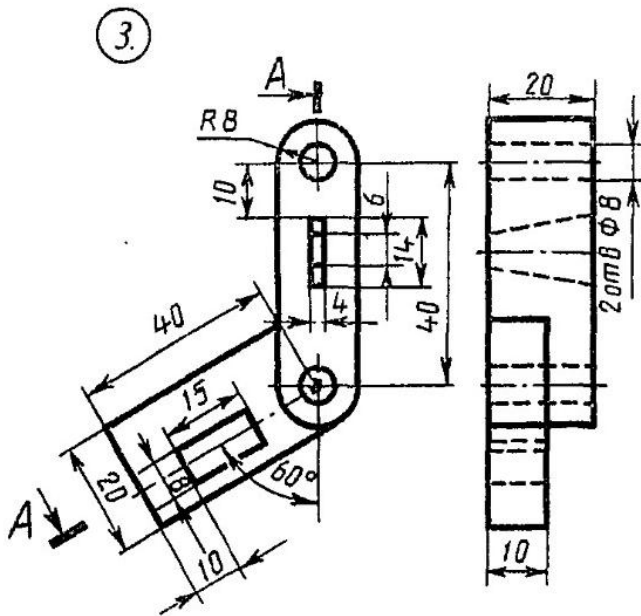

Замок

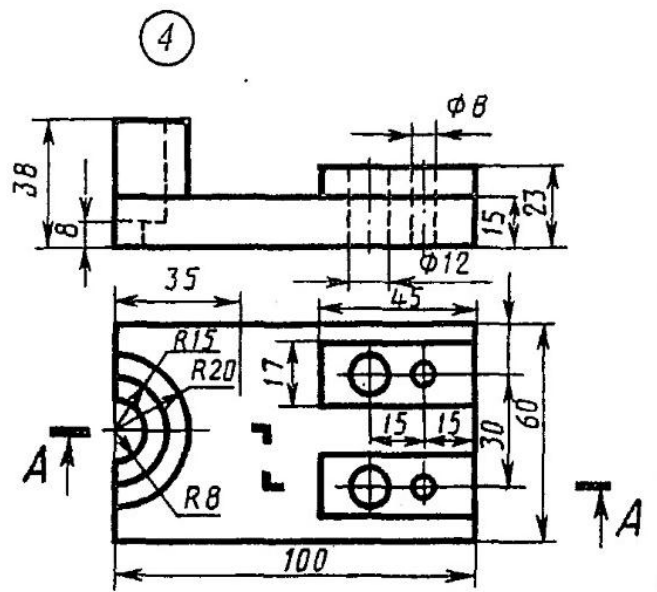

Основание

Вариант 29

1

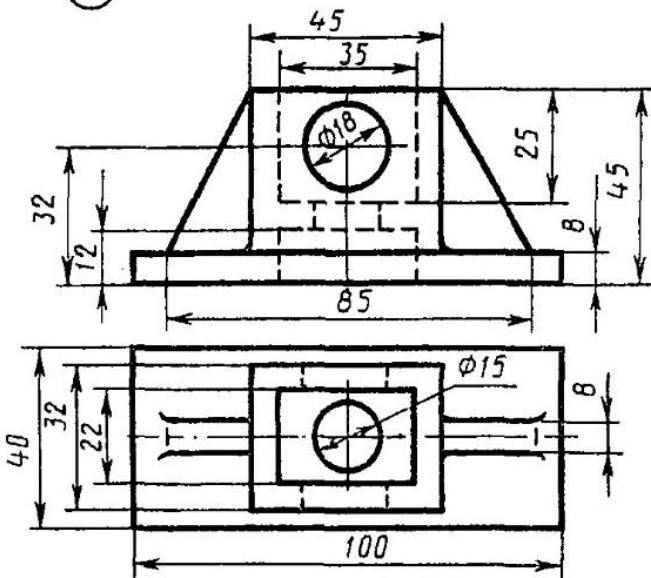

Коробка

2

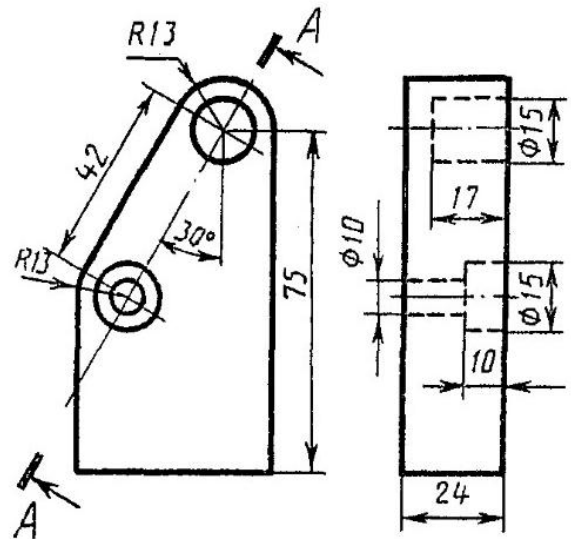

Планка

3

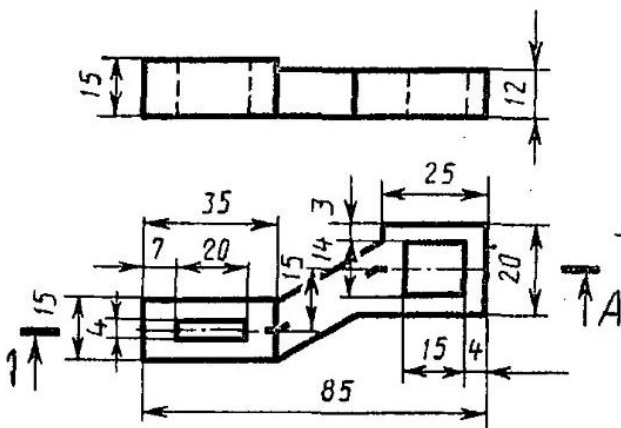

Скоба

4

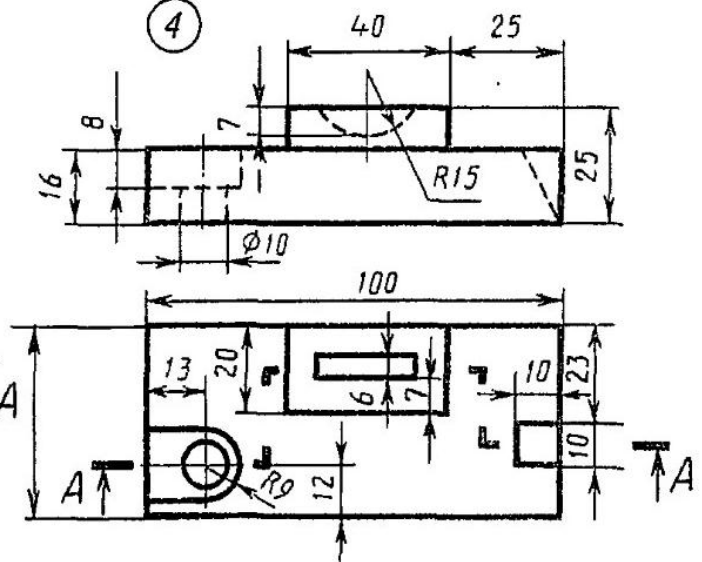

Брусок

Вариант 30

1

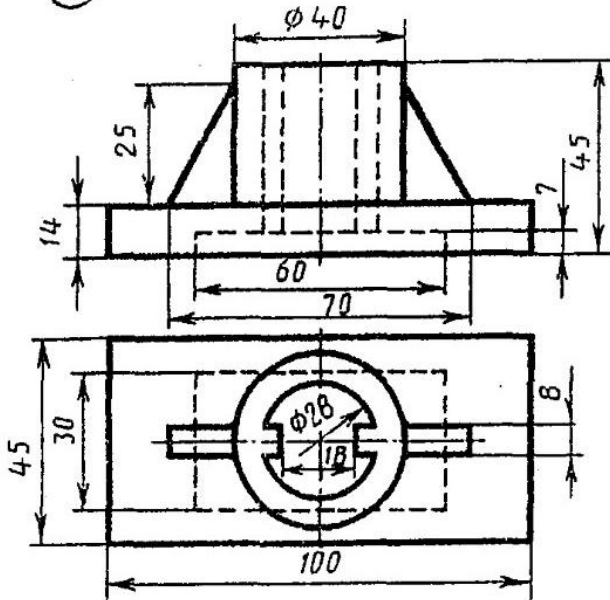

Стойка

2

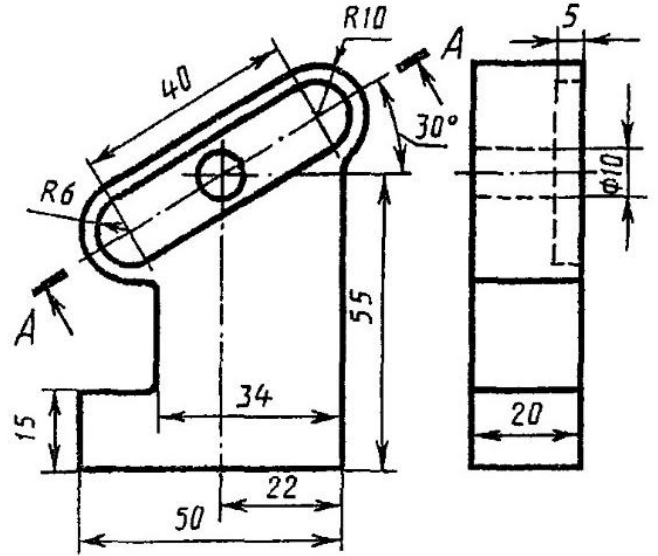

Пластина

3

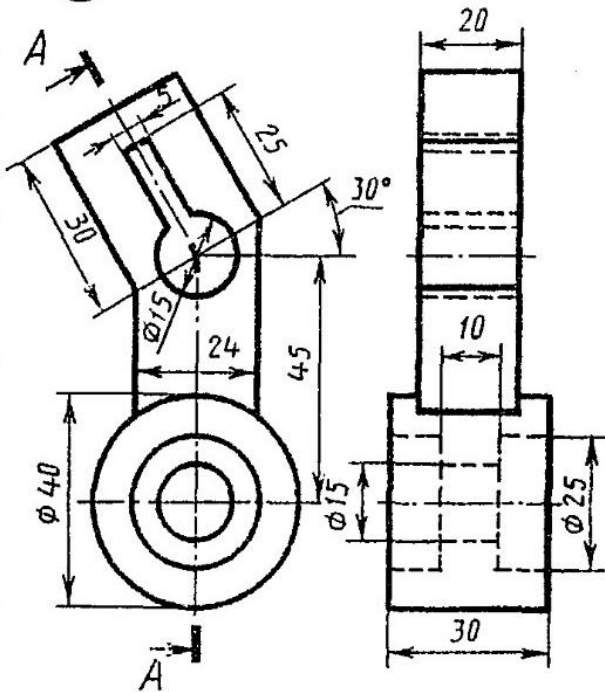

Серьга

4

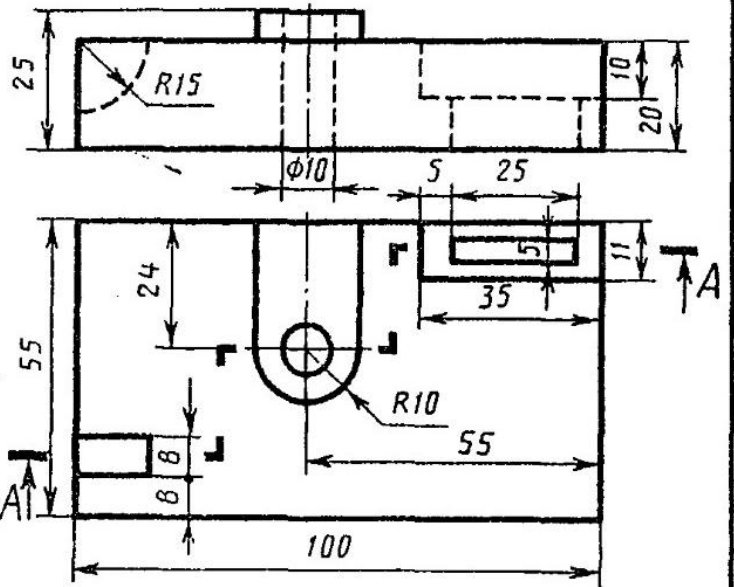

Плита

MAVZU №6: QATLAMLAR (СЛОИ)

- **Qatlam** – bu shaffof chizma muhiti bo'lib, unda ob'ektlar ma'lum bir xususiyatlarga ega bo'ladi va boshqa qatlam muhitiga tegishli bo'lmaydi.
- **Qatlamlar asosida yaratilgan loyiha shaffof kalka yoki plenka qog'ozlarida bajarilgan chizmalarni eslatadi. Ya'ni ushbu chizmalar ustma-ust joylashtirilsa barcha chizmalar bir butun loyihani tashkil etadi.**

Menu satri va **Standart asboblar paneli** bizga informatika fanidan tanish. Ularning aksariyat funksiyalari **Windows** qobig'ining barcha dasturlari (Wopd, Excel, Access) kabidir;

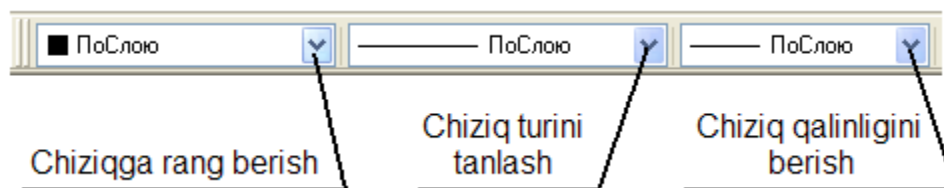

«Свойства» - xususiyatlar paneli chizma chiziqlari rangini, turini va qalinligini belgilab beradi. Faol tugmalardan biri tanlansa interaktiv oyna ochiladi va unda kerakli parametrlar tanlanadi:

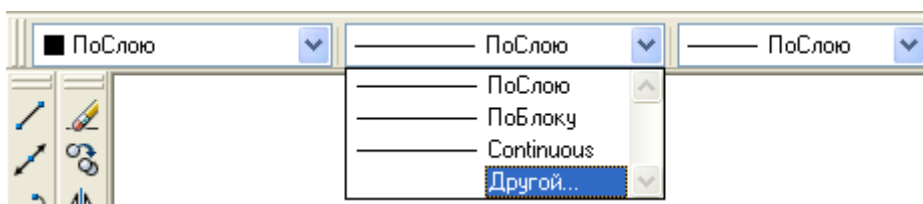

Chiziq turini tanlash tugmasi bosilganda uning ostida axborot oynasi ochilib dastlabki mavjud chiziq turlari ko'rsatiladi. Unda **«Другой» - Boshqa** bandi tanlanadi va **«Диспетчертиповлиний» - Chiziq turlari dispatcher** muloqot oynasi ochiladi. Muloqot oynasidagi **«Загрузить» - Yuklash** tugmasi bosilib, keyingi muloqot **«Загрузка/перезагрузка типовлиний» - Chiziq turlarini yuklash** oynasi ochiladi.

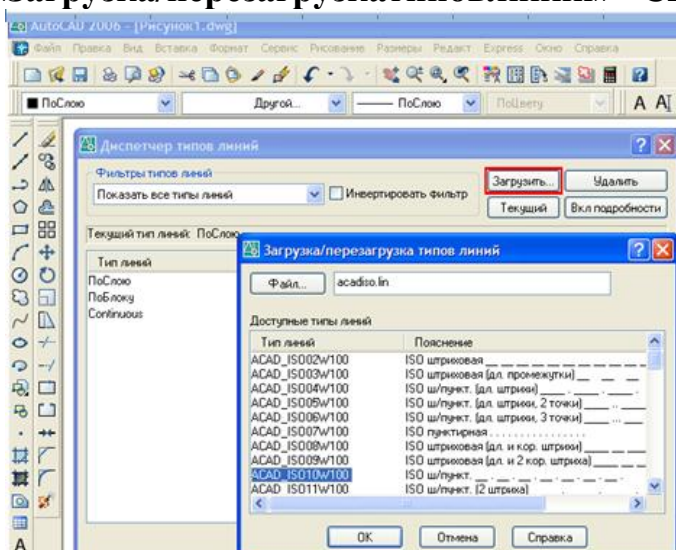

Ushbu faol oynadan kerakli chiziq turi tanlanib, **«OK»** tugmasi bosilsa bo'ldi. **«Прокрутка» - varaqlagich dastaklar** yordamida keyingi chiziq turlarini ko'rish mumkin. **«Диспетчертиповлиний» - Chiziq turlari dispatcher** muloqot oynasida ham **«OK»** tugmasi bosiladi.



1. «Диспетчер свойств слоев» - Qatlamlar xususiyatlari dispatcheri.
2. «Включение / отключение слоя» - Qatlamni yoqish / o'chirish.
3. «Замораживание / размораживание на всех видовых экранах» - Barcha ko'rinish ekranlarida muzlatishni yoqish / o'chirish.
4. «Замораживание / размораживание на текущем видовом экране» - Joriy ko'rinish ekranida muzlatishni yoqish / o'chirish.
5. «Блокирование / разблокирование слоя» - Qatlam qulfini yoqish / o'chirish.
6. «Цвет слоя» - Qatlam rangi.
7. Qatlam nomi.
8. Подменю tugmasi.
9. «Сделать слой объекта текущим» - Joriy ob'ekt qatlamini o'rnatish.
- «Предыдущее состояние слоя» - Qatlamning oldingi holatiga o'tish.

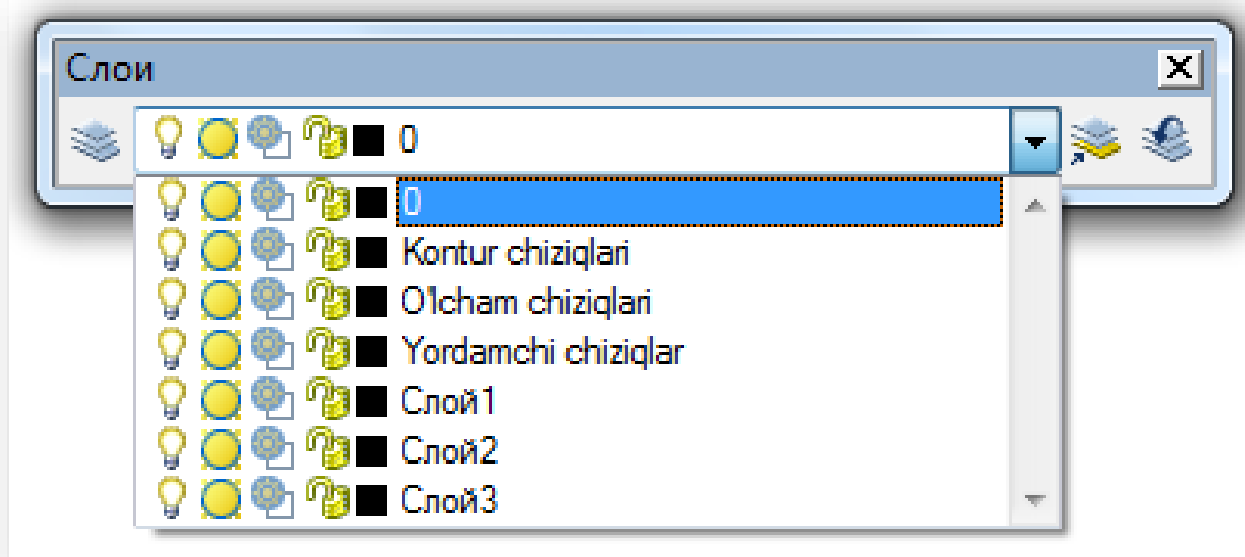

AutoCADda har qanday chizma hech bo'lmaganda bitta qatlam asosida bajariladi (dastlabki qatlam nomi «0»).

Loyihani yaratishda oldindan bir nechta qatlamlarni yaratish va loyiha bosqichlarini alohida qatlamlarda saqlash tavsiya etiladi.

Qatlam yaratish va unga xususiyatlar berish uchun «Диспетчер свойств слоев» – Qatlamlar xususiyatlari dispatcheri tanlanadi.

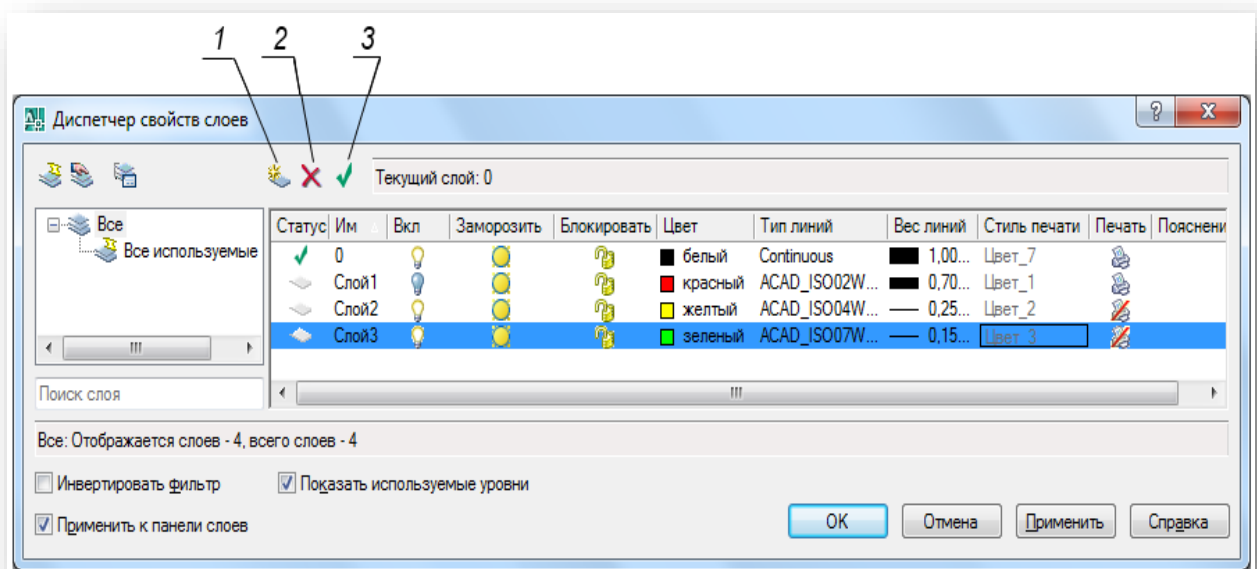

1. **«Создать слой» - Qatlam yaratish.**
2. **«Удалить слой» - Qatlamni olib tashlash.**
3. **«Установить» - O'rnatish.**
 - Qatlam xususiyatlarigacha ziq rangi, turi, qalinligi va chopetish imkoniyatlarini kiradi.
 - Qatlamga xususiyat berish uchun yaratilgan qatlamdagi «Цвет» - Rang, «Тип линий» - Chiziq turi, «Вес линий» - Chiziq qalinligi, «Стиль печати» - Chopetish uslubi, «Печать» - Chopetish kabitegishli ustunlarni tahrirlanadivastlab «Применить» - Qo'llash, so'ngra «OK» tugmasi bilan tasdiqlanadi.
 - Ob'ektyoki ob'ektlarni qatlamga berkitish uchun dastlab ulardan tanlanadivastlab «Слой» - Qatlamlar panelidagi podmenyu asosidakerakli qatlam nomini belgilanadi.
 - Shuningdek qatlamlar panelidastlab biron bir qatlam nomini tanlangan bo'lsa yaratiladigan ob'ektlar shu qatlamga tegishli bo'ladi.

Topshiriqlarni bajarish tartibi

Detal ko'rinishini chizish va o'lchamlar qo'yish

Bolti birikma															
Variantlar	1	3	5	7	9	11	13	15	17	19	21	23	25	27	29
d	16	18	20	22	24	16	18	20	22	24	16	18	20	22	24
L	70	80	90	70	80	90	70	80	90	70	80	90	70	80	90
Spilkali birikma															
Variantlar	2	4	6	8	10	12	14	16	18	20	22	24	26	28	30
d	24	22	20	18	16	24	22	20	18	16	24	22	20	18	16
L	60	55	50	60	55	50	60	55	50	60	55	50	60	55	50

Bolti va shpilkali birikmalar uchun o'lcham munosabatlari:

(d – bolt yoki shpilka tashqi rezba diametri asosida)

h = 0,7*d	r = yasaladi
Lo = (1,5...2) * d	C = 0,15*d
d₁ = 0,85*d	H = 0,8*d
D = 2*d	D_{sh} = 2,2*d
D₁ = S – 3...4 mm	d_{sh} = 1,1*d
S = yasaladi	S_{sh} = 0,15*d
R = 1,5*d	L₁ = d

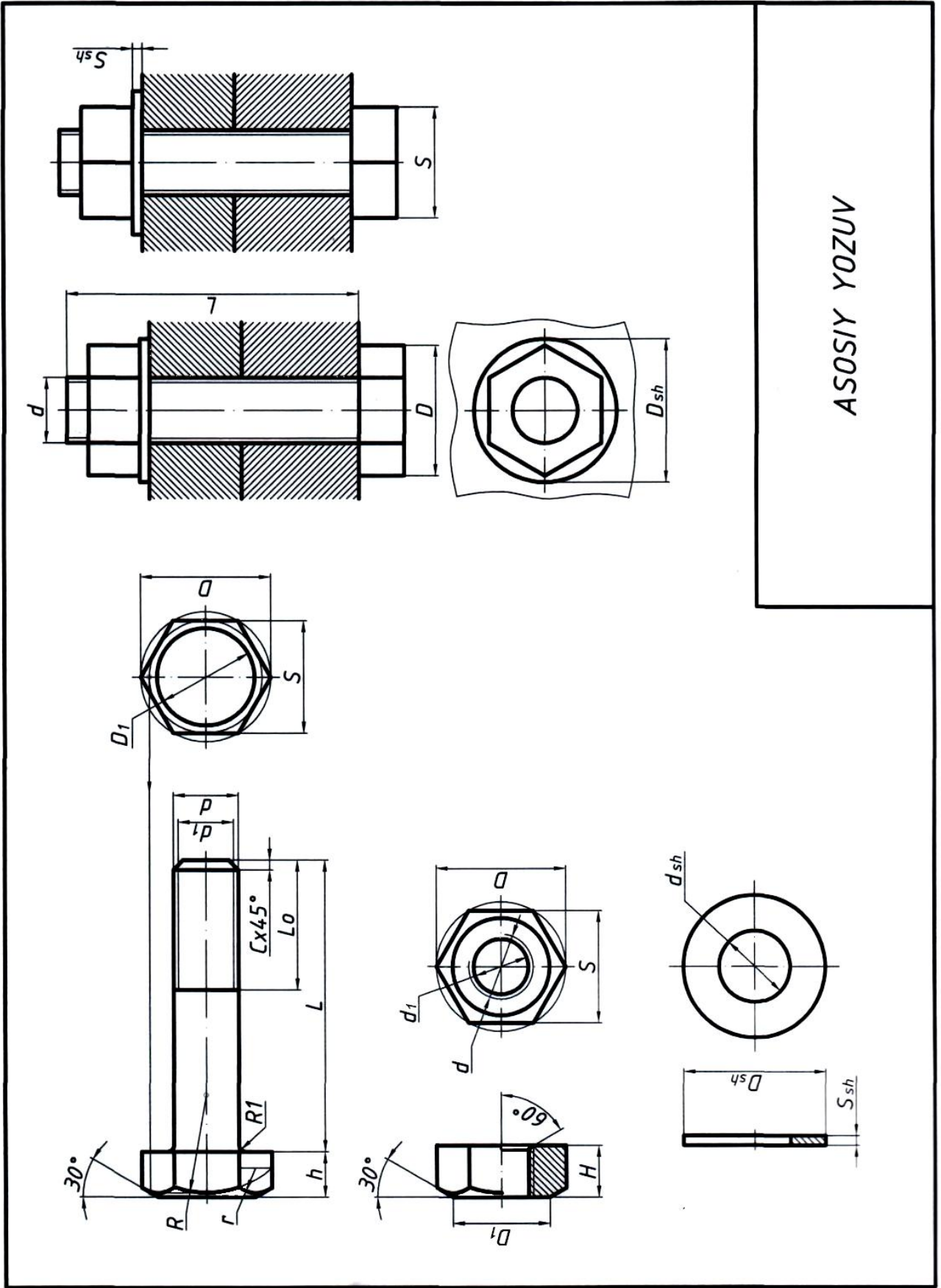

ASOSIY YOZUV

Bolti birikma

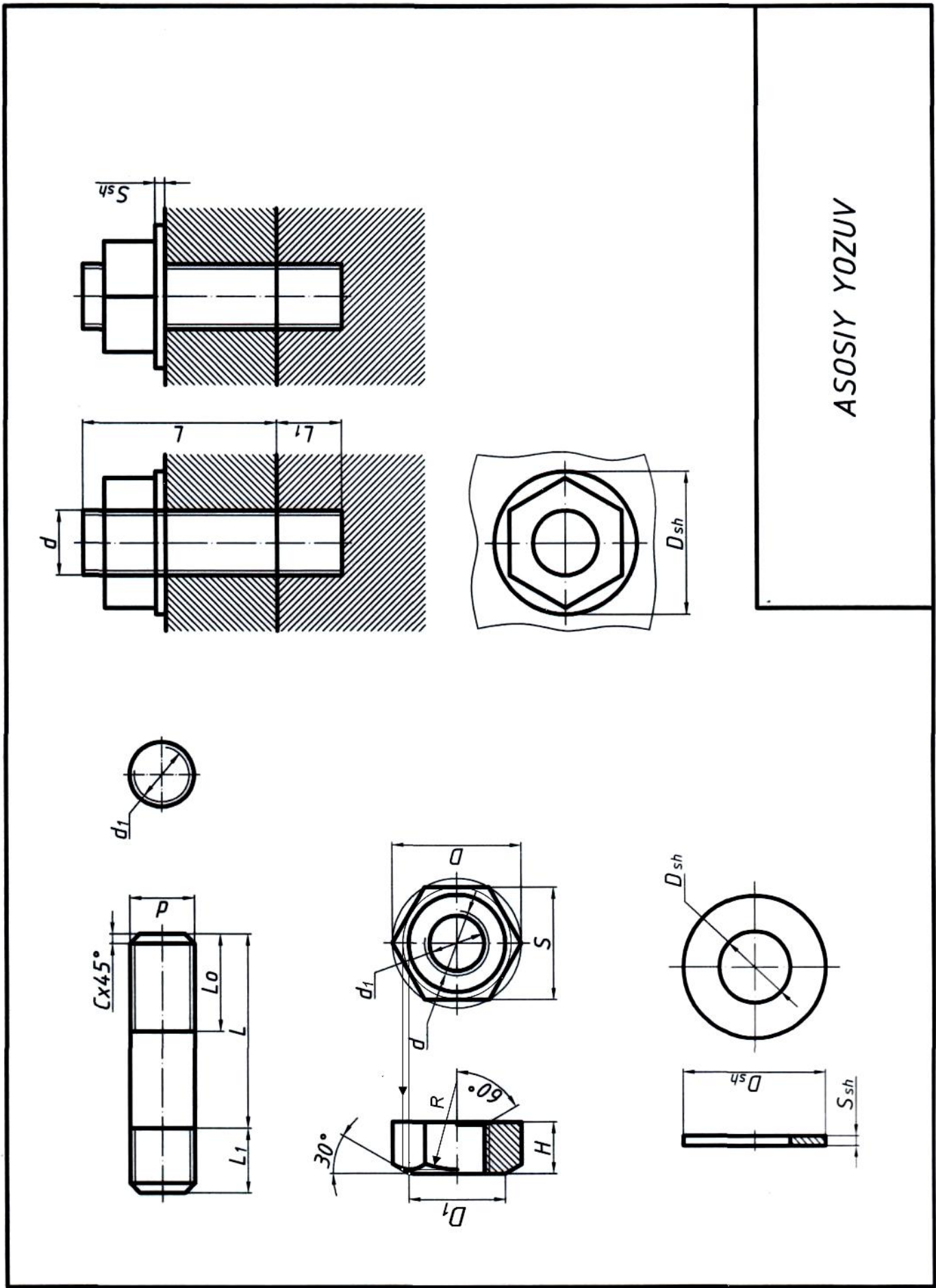

ASOSIY YOZUV

Shpilkali birlikma

MAVZU №7: AUTOCAD DA UCH O'LCHAMLI TASVIRLAR – 3D TUSHUNCHASI VA SIRTLARNI HOSIL QILISH

3Dmodelashtirishhaqidatushuncha

3Ding. 3 deminsion – ucho'lchamlideganso'zdan kelib chiqqan bo'lib, ushbu tushuncha asosida ucho'lchamga ega bo'lgan yuzali, hajmli va hajmsiz geometrik figuralar tushuniladi.

Hajmli geometrik figuralarga *jismlar*, yuzali geometrik figuralarga *sirtlar* va hajmsiz geometrik figuralarga *fazoviy egrichiziq* larkiradi.

Bugungi kunda 3Dmodellari asosan kichik to'yifagaman subbo'lgan geometrik modellardan iborat bo'lib, bular – jismlar (тела) va sirtlar (поверхности)dir. Aynan bir xil geometrik tuzilishga ega bo'lgan figuralar jisim yoki sirdan iborat bo'lishi mumkin.

Ichibo'sh bo'lmagan hajmli, yopiq to'plamdan iborat geometrik figura *jism* deb, ichibo'sh qobiqdan iborat hajmli yoki faqat yuzaga ega hajmsiz geometrik figura esa *sirt* deb atyiladi.

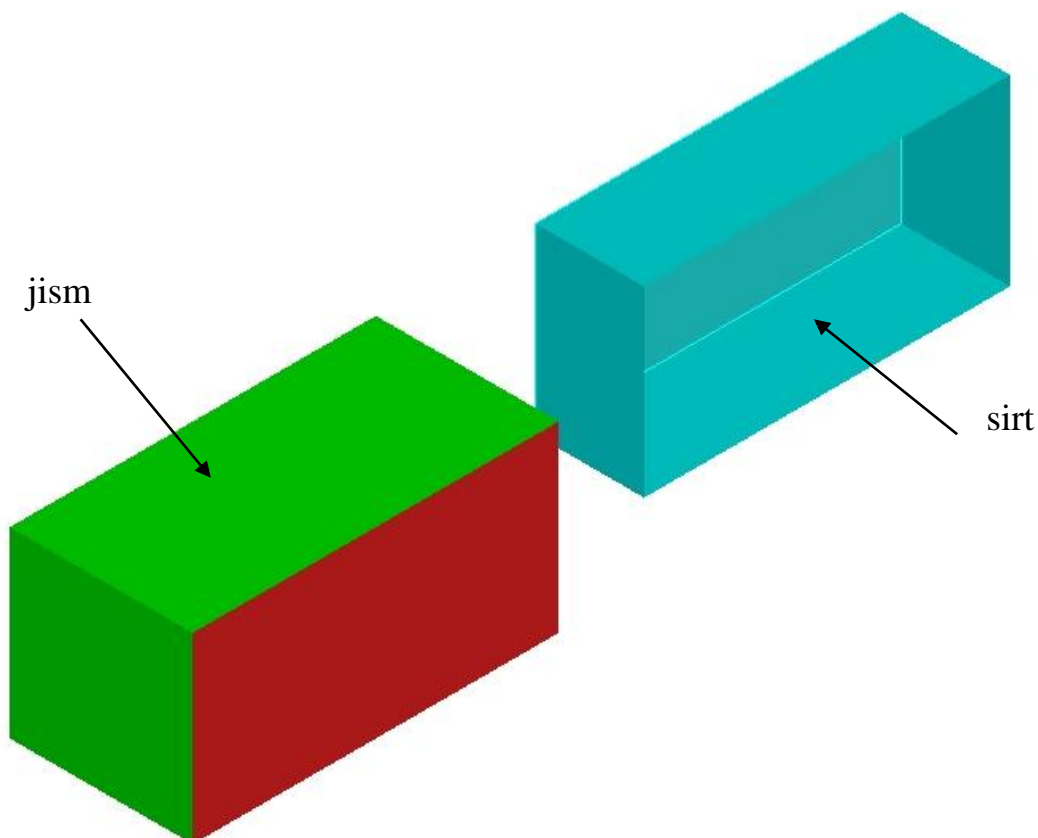

Misol uchun: sfera, kub, prizmalaragar ichibo'shliqdan iborat qobiq bo'lsa, ular *sirtlar* deb, aks holda *jismlar* deb qaraladi. Bundan shunday xulosa qilish mumkin ki,

harikkitoifagamansub

3Dmodellar tuzilish jihatidan bir xil geometrik qoq nuniyatlarasosida quriladi.

Sirtlar geometriyasivaklassifikatsiyasi

Barcha cho'lamli ob'ektlar sirtlardan tashkil topgan bo'lib, ularning ichi bo'sh yoki to'lab o'lishi ularning geometriyasigata sirqilmaydi.

Odatda sirt deganda silliq varavonegrilikdan iborat geometrikyuzatushuniladi, ammo ilm-fandatekislik, ko'pyoqlik hamsirt ekanligi, faqat ushbu sirtlar egriliginolga teng ekanligi isbotlangan. Jumladan, tekislik – *tekis sirt*, ko'pyoqlik esa – *yoqlisirt*, *qirralisirt* deb ham ataladi.

Geometrik nuqtai nazardan sirt biror bir chiziqni fazodagi harakati va ushbu harakat natijasida chiziqning fazoda egallagan vaziyatlari to'plamiga aytiladi.

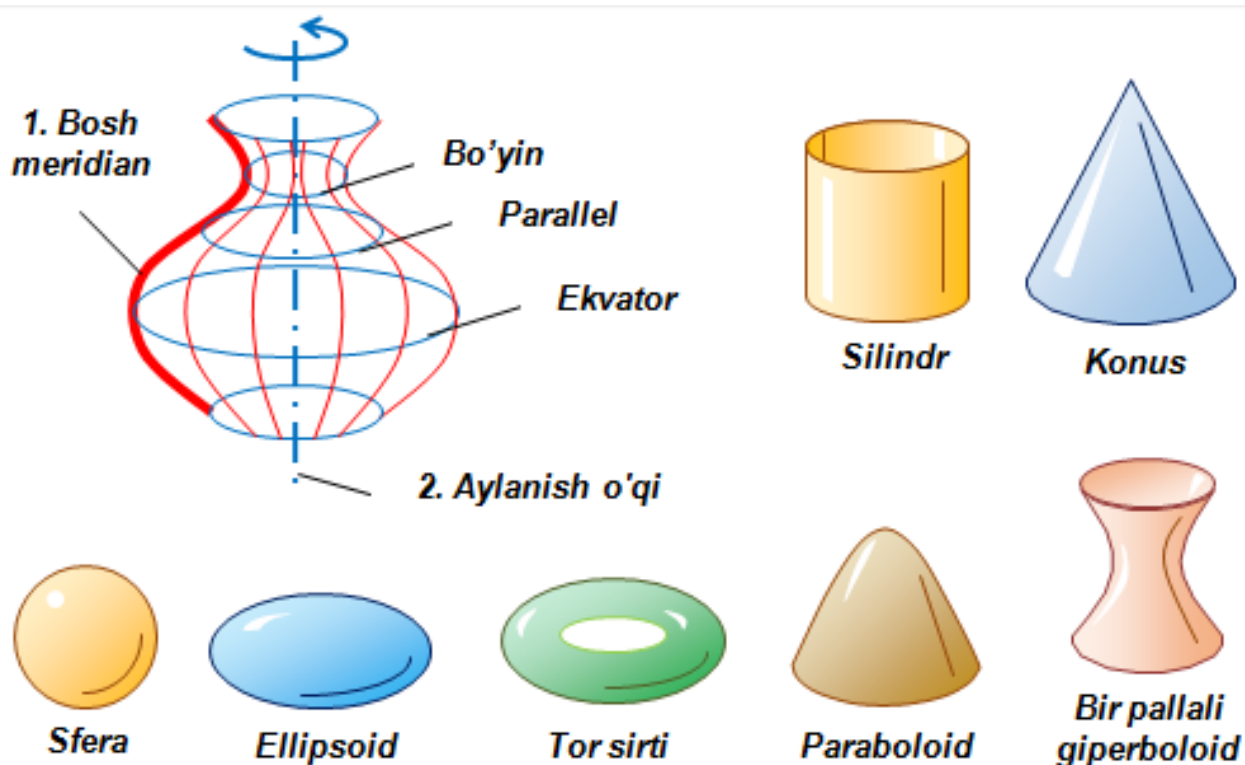

Jismlar geometriyasi

Geometrik nuqtai nazardan jism bo'sh bo'lmagan to'plamdan iborat bo'lishi, agar bu to'plam nuqtali bo'lsa nuqtalar to'plamidan, biron bir oilaga mansub chiziqlardan iborat bo'lsa chiziqli to'plam bo'lishi kerak.

Geometriyaning aksiomalaridan ma'lumki agar nuqta to'g'ri chiziqqa va to'g'ri chiziq biron bir tekislikka tegishli bo'lsa, nuqta ham o'sha tekislikka tegishli bo'ladi. Bundan shu narsani xulosa qilish mumkinki, tekislikda ham chiziqli, ham nuqtali to'plamlar mavjud.

Demak jism bu biron bir tekislikni fazoda harakati davomida hosil qilinadigan tekisliklar majmuasidir.

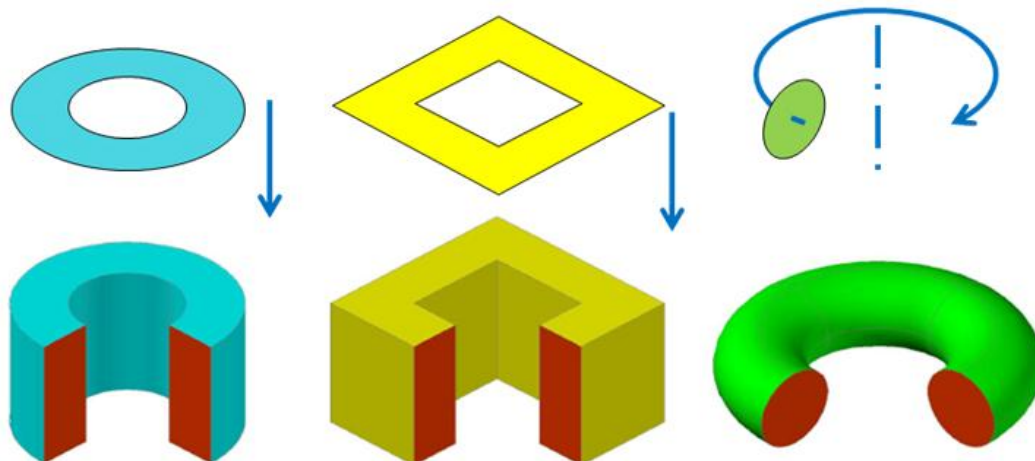

Murakkab geometrik tuzilishga ega bo'lgan jismlar bir nechta geometrik jismlarni birlashuvi yoki ayirmasi asosida hosil qilinadi.

AutoCAD dasturini 3D muhitini sozlash

AutoCAD dasturida 3D modellarini qurish uchun dastlab dasturni 3D muhitida ishlash uchun moslashtirish kerak bo'ladi. Buning uchun 3D geometrik ob'ektlarni yaratish, tahrirlash vizuallashtirish kabi funksiyalar bilan bog'liq qo'shimcha panellarni ekranga chiqarish talab etiladi.

Qo'shimcha panellarni ekranga chiqarish uchun ekranda mavjud panellardagi biron bir buyruq piktogrammasi ustida sichqoncha o'ng tugmasi bosiladi va AutoCAD panellari ro'yxati ekranga chiqariladi.

3D modelashtirish panellari ro'yxati

1. «Вид» - «Ko'rinish»,
2. «Визуальные стили»- «Vizualuslublar»,
3. «Моделирование»- «Modellashtirish»,
4. «Орбита» - «Orbita»,
5. «ПСК» (пользовательская система координат) - «FKT» (foydalanuvchikoordinatalartizimi),
6. «Редактирование - 2»- «Tahrirlash-2»,
7. «Редактирование тела»- «Jismnitahrirlash».

Panellar ro'yxati

Ish jarayonida panellar vaziyatini o'zgartirib turish tavsiya etilmaydi. Slaydda keltirilgan panellarni joylashuvi namuna sifatida keltirilgan bo'lib, ular o'rnatib chiqilgandan so'ng albatta panellar vaziyatini dastur xotirasida saqlab qolish tavsiya etiladi va panellar joylashuvi o'zgartirib yuborilganda saqlangan ish muhitiga o'tib panellarning oldingi vaziyatini tiklash mumkin bo'ladi.

3D primitivlari va ular bilan ishlash

AutoCAD dasturida oddiy 3D primitivlari mavjud bo'lib ular «**Моделирование**» - «Modellashtirish» panelida joylashgan.

Panel 4 bo'limdan iborat.

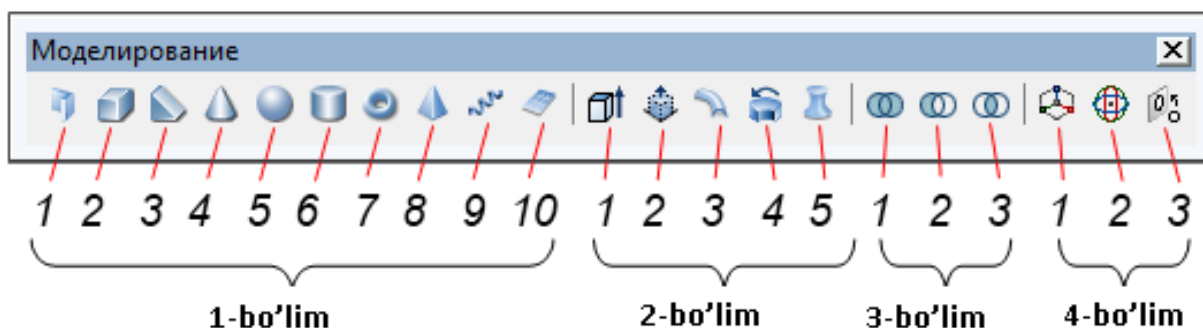

1. «**Политело**» – «Polijism»;
2. «**Ящик**» – «Qutti»;
3. «**Клин**» – «Pona»;
4. «**Конус**»;
5. «**Сфера**»;
6. «**Силиндр**»;
7. «**Тор**»;
8. «**Пирамида**»;
9. «**Спираль**»;
10. «**Плоская поверхность**» – «Tekissirt (Tekislik)».

Ushbu bo'limdagibarchabuyruqpiktogrammalario'zmenyusigaegabo'lib, ular ob'ektlarnigeometrikparametrlariasosidaqurishninazardatutadi. Bunday geometrik parametrlarga quriladigan 3D ob'ektini eni, bo'yi, balandligi, markazi, radiusi kabi xususiyatlari kiradi.

2-bo'lim dasturliuslubdajismvasirtlarniqurishbuyruqpiktogrammalarijoylashgan. Ushbu bo'limda oldindan yaratigan 2D ob'ektlari asosida 3D sirt yoki jismlari yaratiladi. Ya'ni sirt yoki jismlar yasovchi va yo'naltiruvchilar asosida quriladi.

SHuning uchun dastlab sirt yoki jismlarning yasovchi va yo‘naltiruvchilarini qurish talab etiladi.

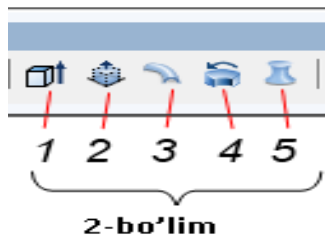

1. «Выдавить» – «Siqibchiqarmoq»;
2. «Вытягивание» – «Cho‘zmoq»;
3. «Sdvig» – «Siljish»;
4. «Вращать» – «Aylantirish»;
5. «По сечениям» – «Kesimlarbo‘ylab».

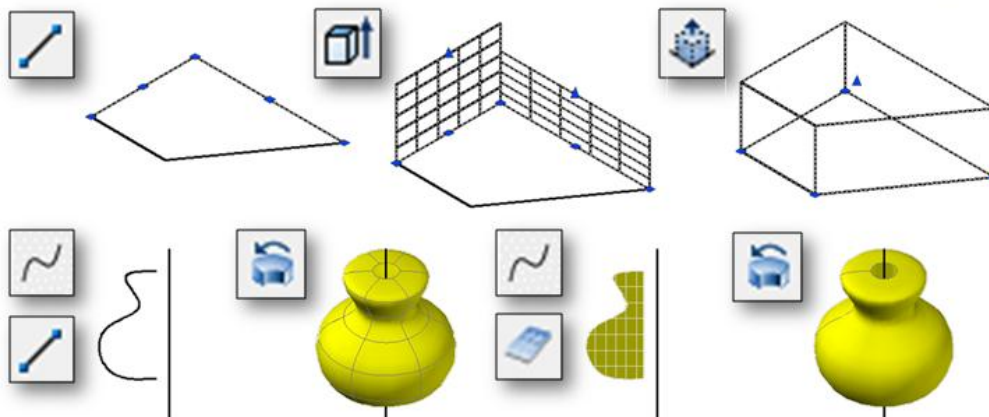

sirt jism

3-bo‘limda tarkibli jismlarni hosil qilish buyruq piktogrammalari joylashgan. Ushbu bo‘lim asosida oldindan yaratilgan jismlar bir-biri bilan birlashib, biri ikkinchisidan ayrilib yoki ikki jism o‘zaro kesishib yangi jism hosil qilinadi. Bunday jismlar tarkibli jismlar deyiladi.

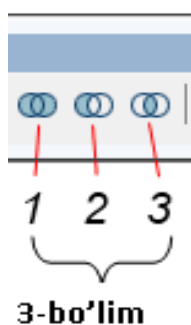

1. «Объединение» – «Birlashuv»;
2. «Вычитание» – «Ayiruv»;
3. «Пересечение» – «Kesishuv».

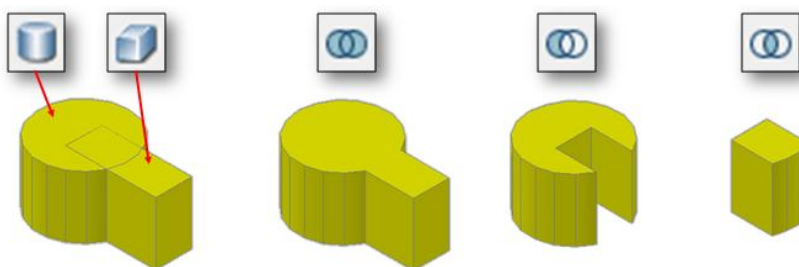

1. «Объединение»
«Birlashuv»
2. «Вычитание»
«Ayiruv»
3. «Пересечение»
«Kesishuv»

4-bo'limda 3D ob'ektlarni fazo bo'ylab ko'chirish, burish, bir-biriga tekislash buyruq piktogrammalari joylashgan.

Ushbu bo'limda yaratilgan 3D ob'ektlari x, y va z o'qlari bo'ylab bir joydan ikkinchi joyga ko'chirilishi, burilishi va o'zaro bir-biriga tekislab olinishi mumkin.

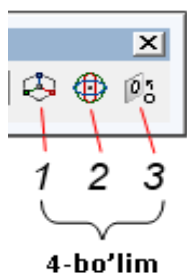

1. «3D perenos» – «3D ko'chirish»;
2. «3D povorot» – «3D burish»;
3. «3D выравнивание» – «3D tekislamoq (to'g'rilamoq)».

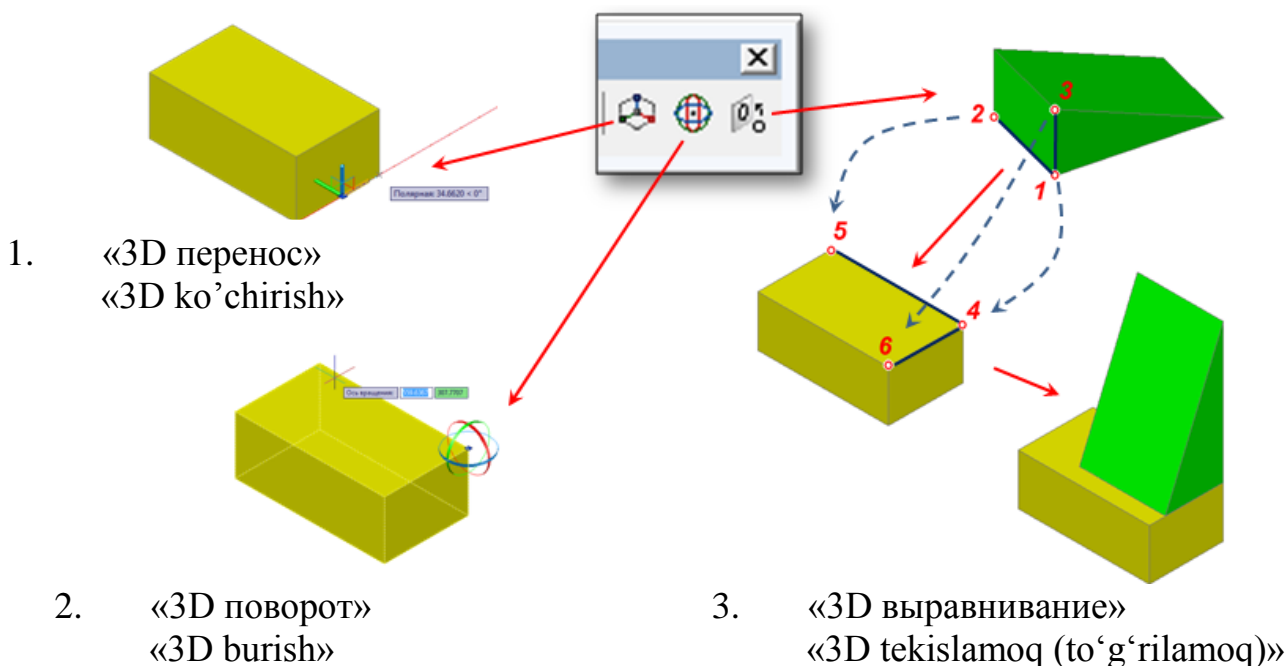

Ko'rinish paneli

Panel asosan 2 bo'limdan iborat.

1-bo'limda asosiy ko'rinishlar bo'lib, unda quyidagi buyruq piktogrammalari joylashgan, bular:

1. «Сверху» – «Ustidan»;
2. «Снизу» – «Ostidan»;
3. «Слева» – «CHadan»;
4. «Справа» – «O'ngdan»;
5. «Спереди» – «Oldindan»;
6. «Сзади» – «Ortdan».

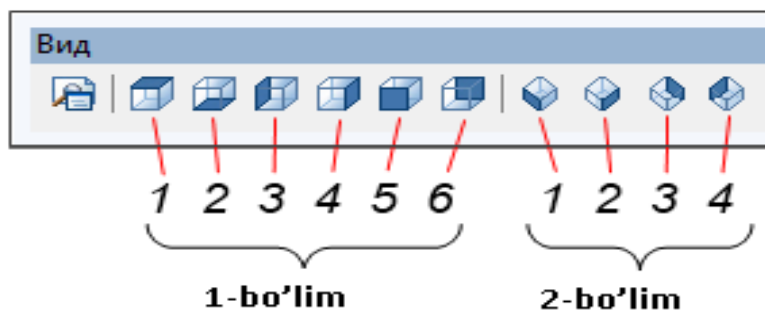

2-bo'limda izometrik proeksiya ko'rinishlarini buyruq piktogrammalarini joylashgan, bular:

1. «ЮЗ (юго-западная)» – «JG' (janubiy-g'arbiy)»;
2. «ЮВ (юго-восточная)» – «JSh (janubiy-sharqiy)»;
3. «СВ (северо-восточная)» – «ShSh (shimoliy-sharqiy)»;
4. «СЗ (северо-западная)» – «ShG' (shimoliy-g'arbiy)».

Orbita paneli

Odatda 3D ob'ektlari izometrik proeksiyalar muhitida bajariladi, sababi bu muhitda uchala koordinata o'qlari (x,y,z) to'liq ko'rinib turadi va qurilayotgan ob'ekt to'la namoyon bo'lib turadi.

Ko'rinishlar asosida 3D ob'ektlarni ixtiyoriy olti tomondan va 4 xil vaziyatdagi izometrik proeksiyalarda ko'rsatish mumkin bo'ladi.

Ayrim 3D ob'ektlari 4 ta izometrik proeksiyalardan birida qulay vaziyatdagi tasvirni bermasligi mumkin. Misol uchun kubni olsak. Bunda kub izometriyada teng yonli olti burchak shaklida ko'rinib qoladi.

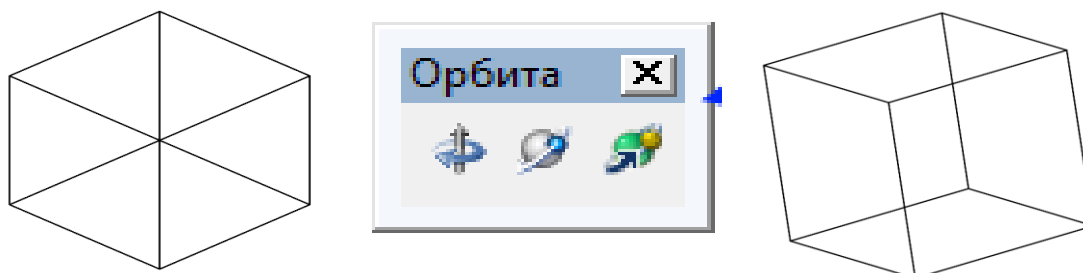

Shuning uchun ko'rinishlarda va umuman modellashtirishda «Orbita» panelidan foydalanish ancha qulayliklarga ega. Ushbu panel asosida ob'ekt ko'rinishi ixtiyoriy burchak ostida burilib ko'rsatilishi va harakatlantirilishi mumkin.

Jismni tahrirlash paneli

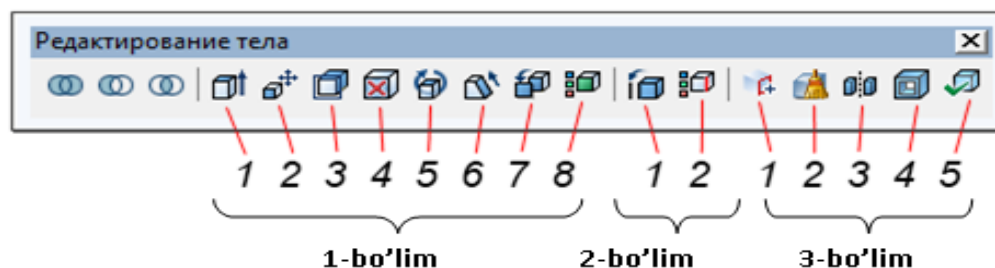

1-bo'lim jism yoqlarini tahrirlash (cho'zish, qisqartirish, burish, rangini o'zgartirish va nusxa ko'chirish)ga qaratilgan buyruq piktogrammalaridan iborat. Bu bo'lim asosida jismdan sirtlarni ajratib olish mumkin bo'ladi.

2-bo'lim jism qirralarini tahrirlash (nusxa ko'chirish, rangini o'zgartirish)ga qaratilgan buyruq piktogrammalaridan iborat.

3-bo'lim jismlarda murakkab tahrirlash ishlarini amalga oshirish (qo'shimcha qirra qo'shish asosida yangi yoqlarni hosil qilish, jismlarni soddalashtirish orqali 3D ob'ektini yaxlitligini tekshirish, jism sirtlariga qalinlik berish orqali jism ichida bo'shliq hosil qilish kabi funksiyalar)ga qaratilgan.

Eslatma

Jismlarni geometrik tuzilishidan kelib chiqib bitta 3D ob'ektini turli usulda bajarish imkoniyatlari mavjud. 3D ob'ektini qaysi usulda yaratish muhim emas, asosiysi ushbu ob'ektlarni foydalanuvchi o'ziga qulay qilib o'zlashtirgan uslubda bajarishi va model keyingi loyihalash jarayonlarida qo'llanish imkoniyatiga ega bo'lishi muhimdir.

3Dmodelashtirishhaqidatushuncha

Berilgan aksonometriya proyeksiyadan uchda perpendikulyar proyeksiyalash

Вариант 1

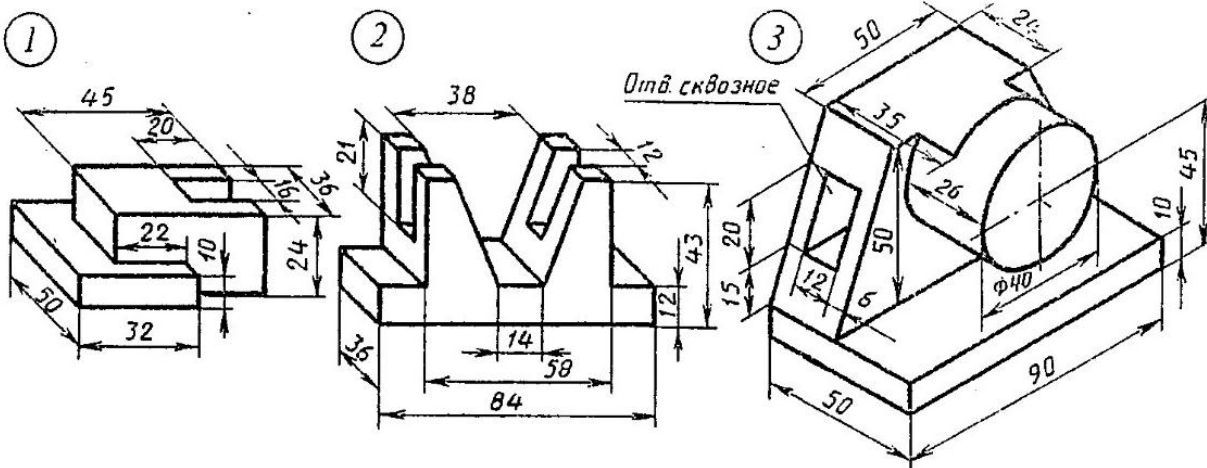

Вариант 2

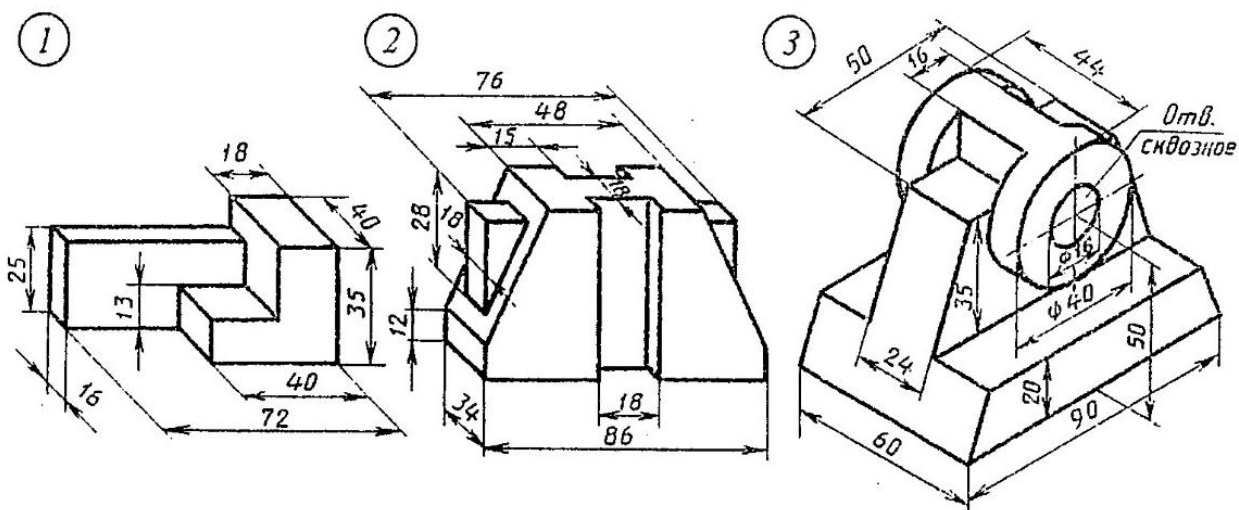

Вариант 3

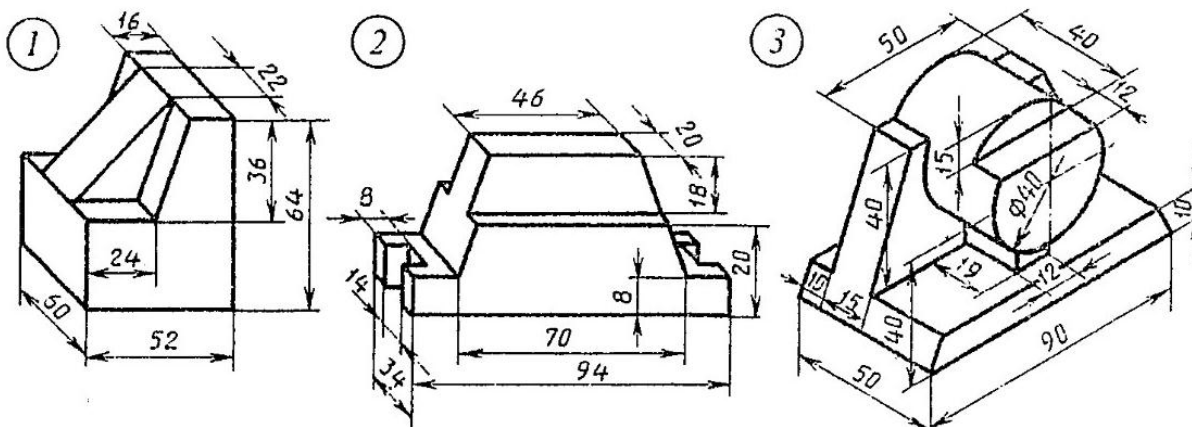

Вариант 4

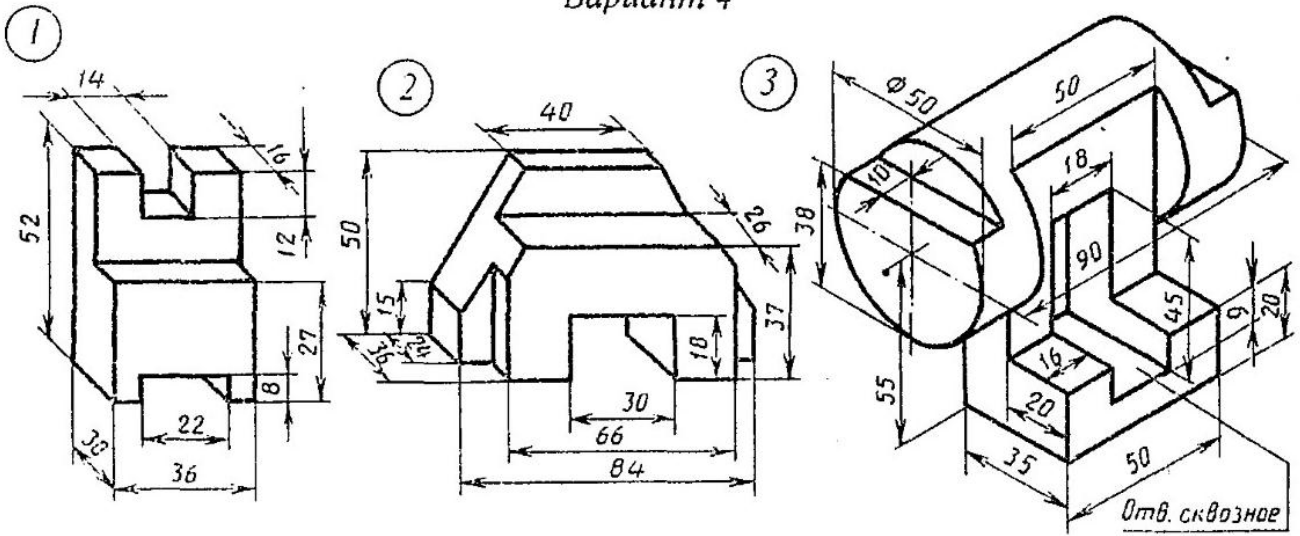

Вариант 5

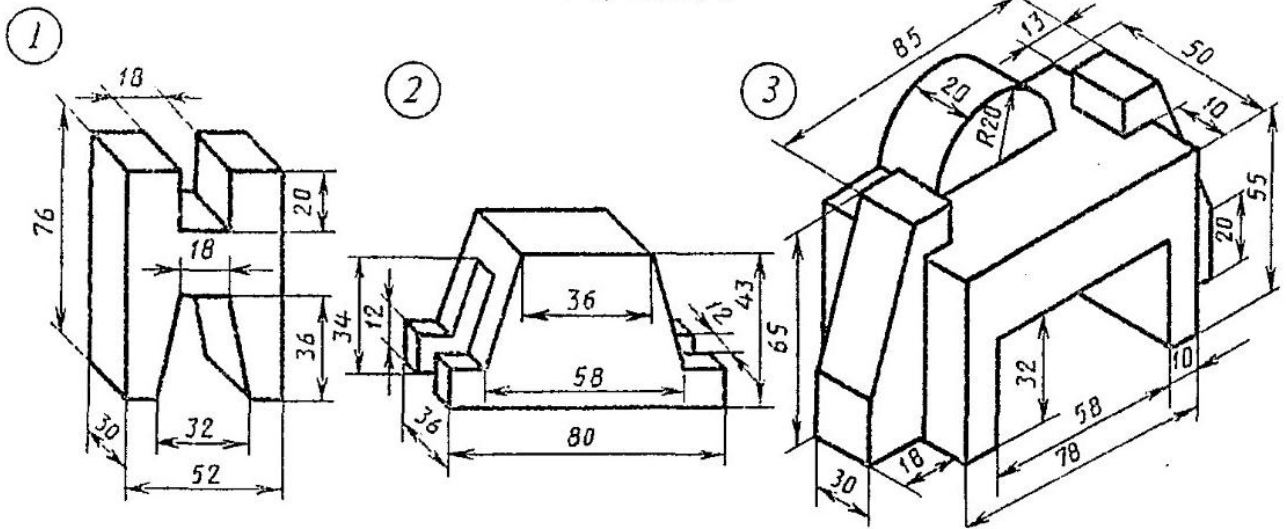

Вариант 6

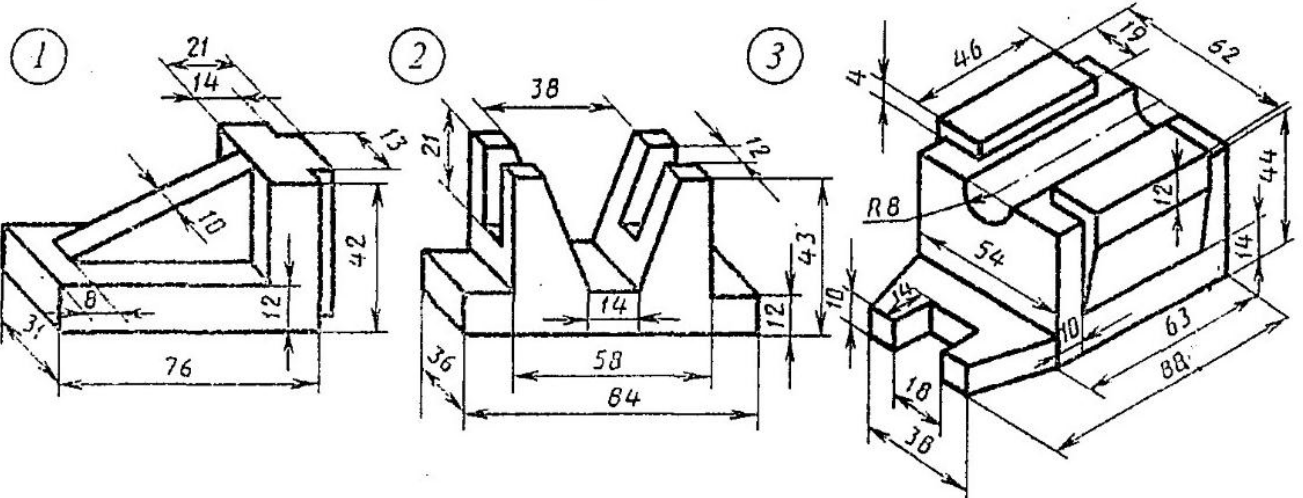

Вариант 7

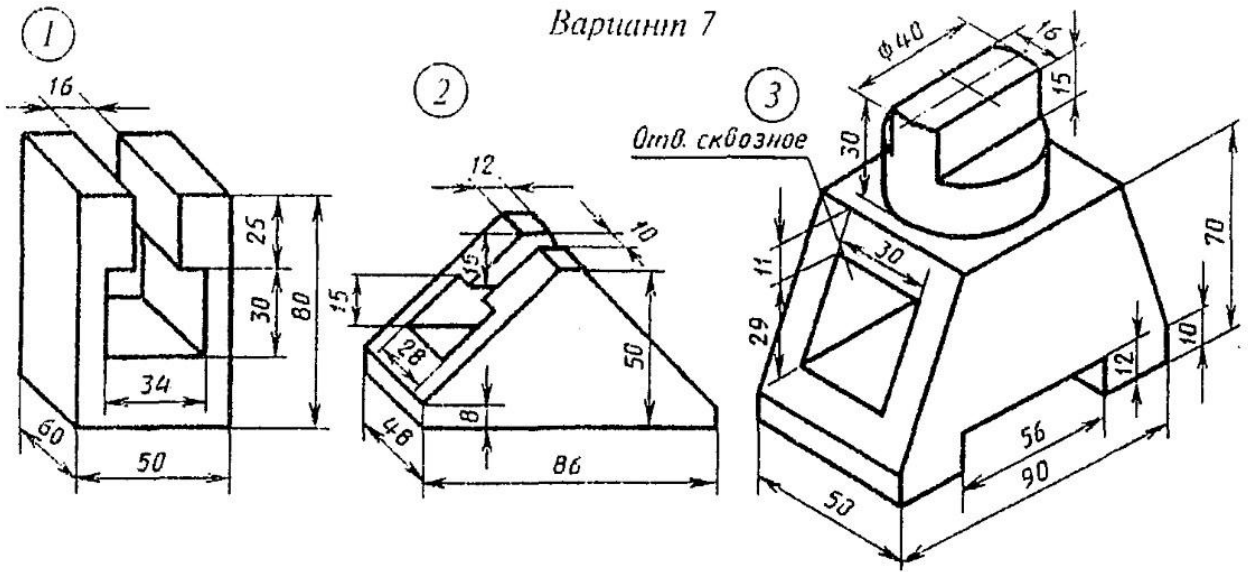

Вариант 8

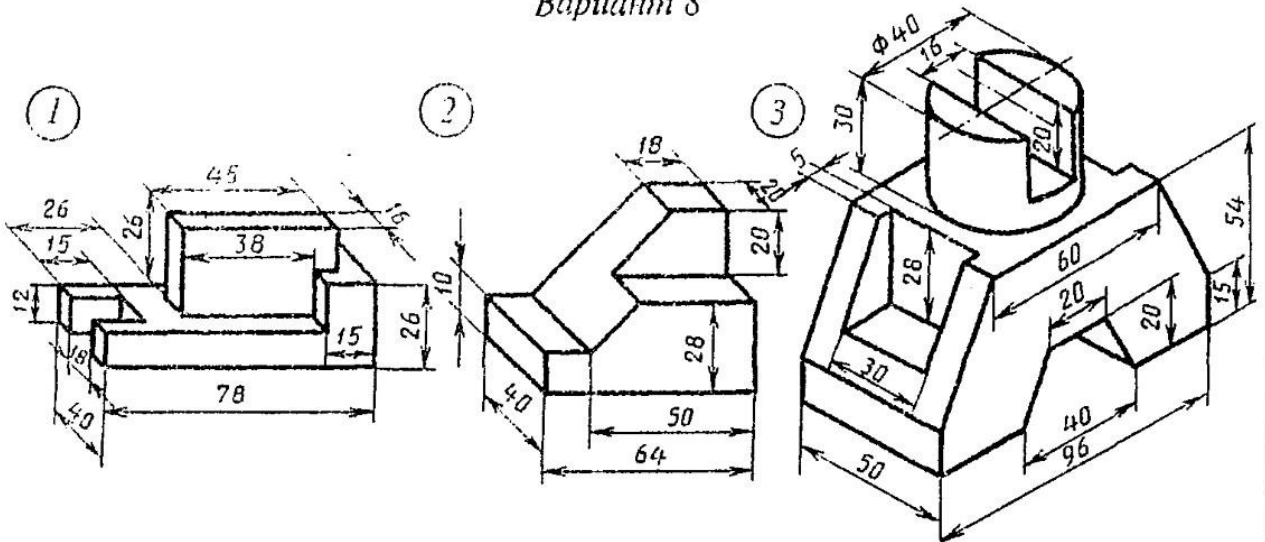

Вариант 9

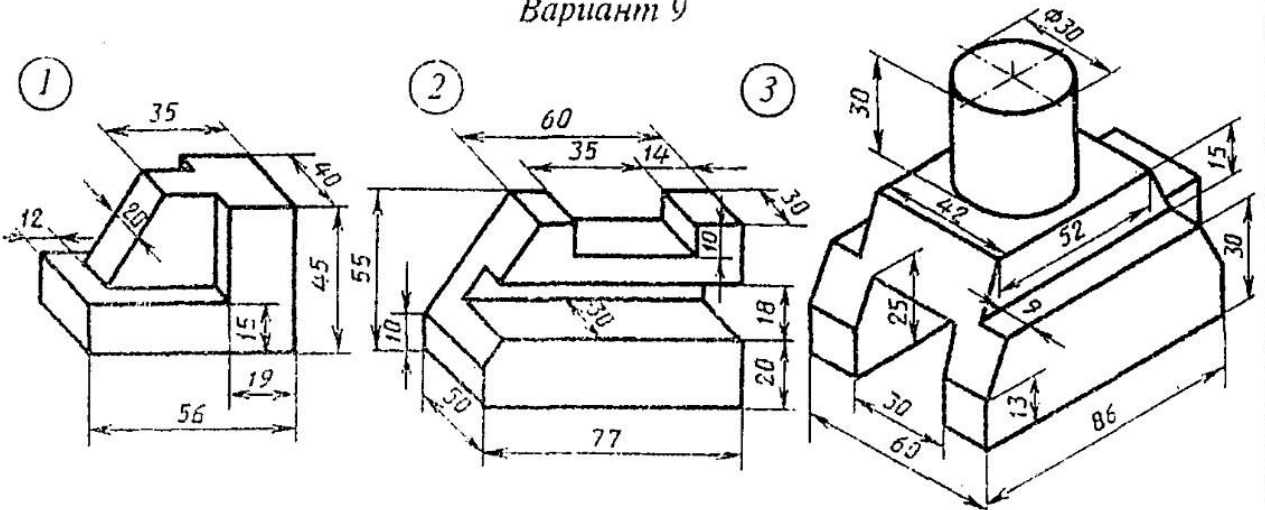

Вариант 10

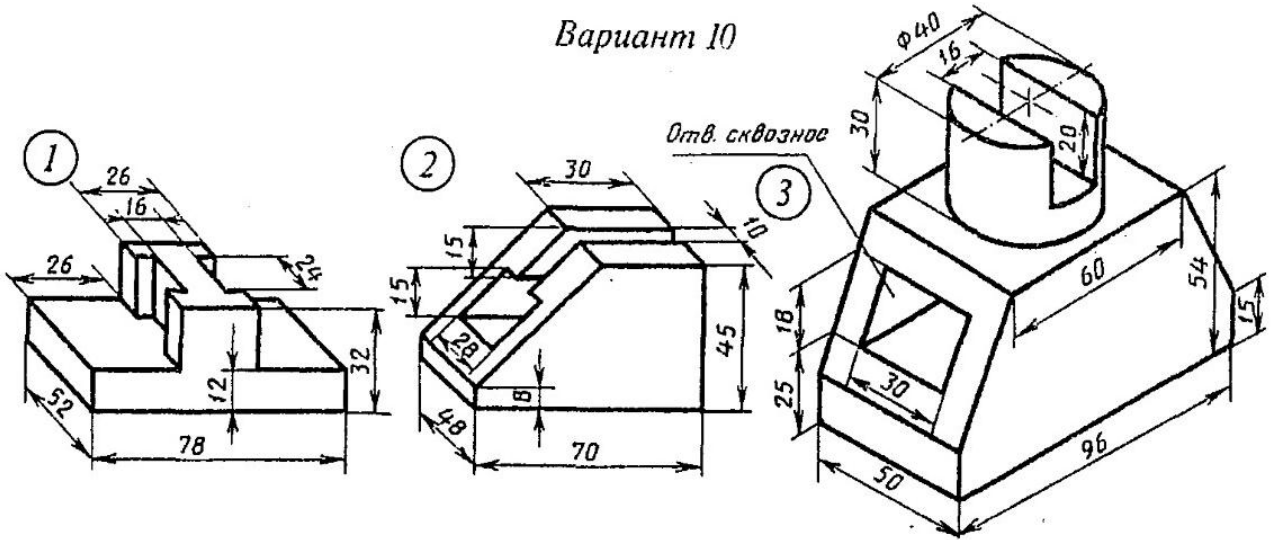

Вариант 11

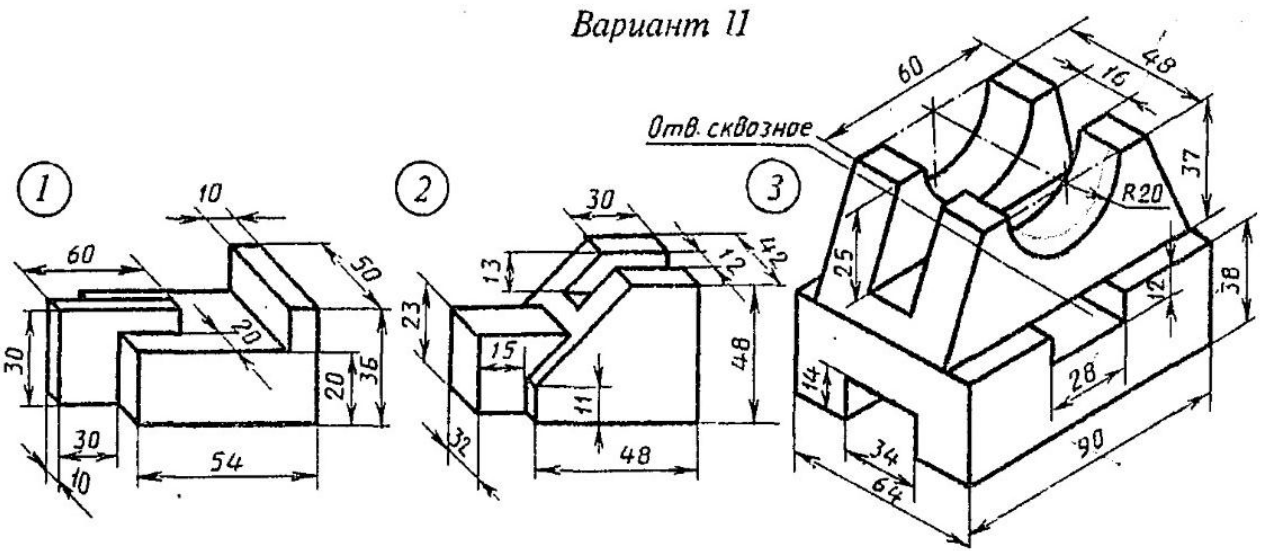

Вариант 12

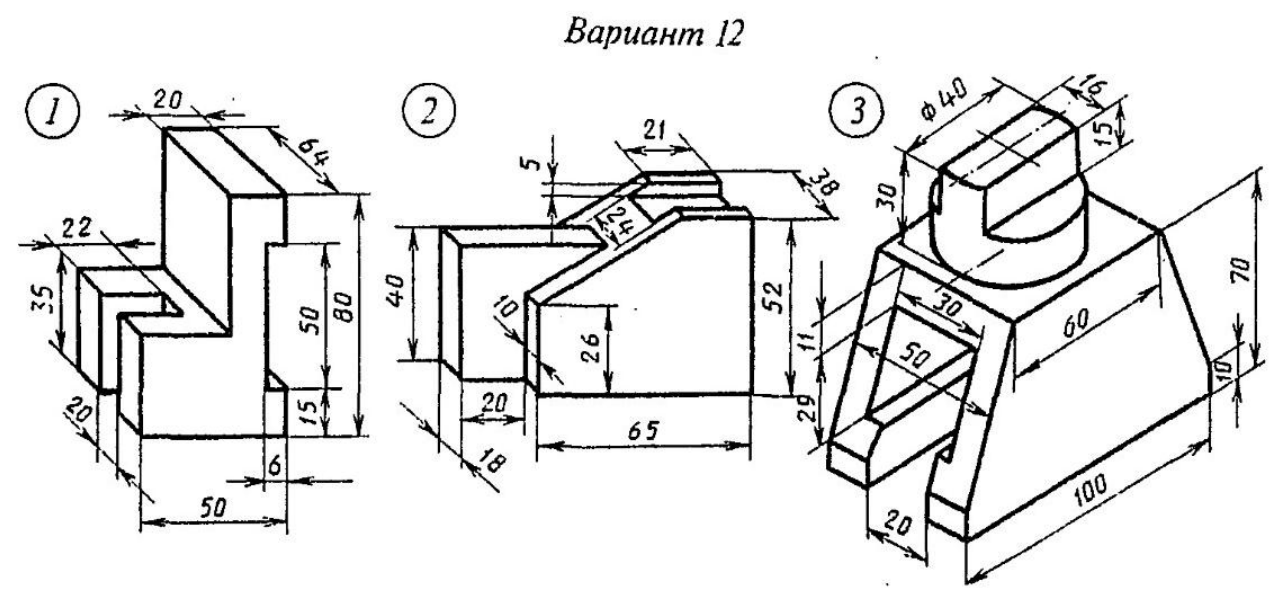

Вариант 13

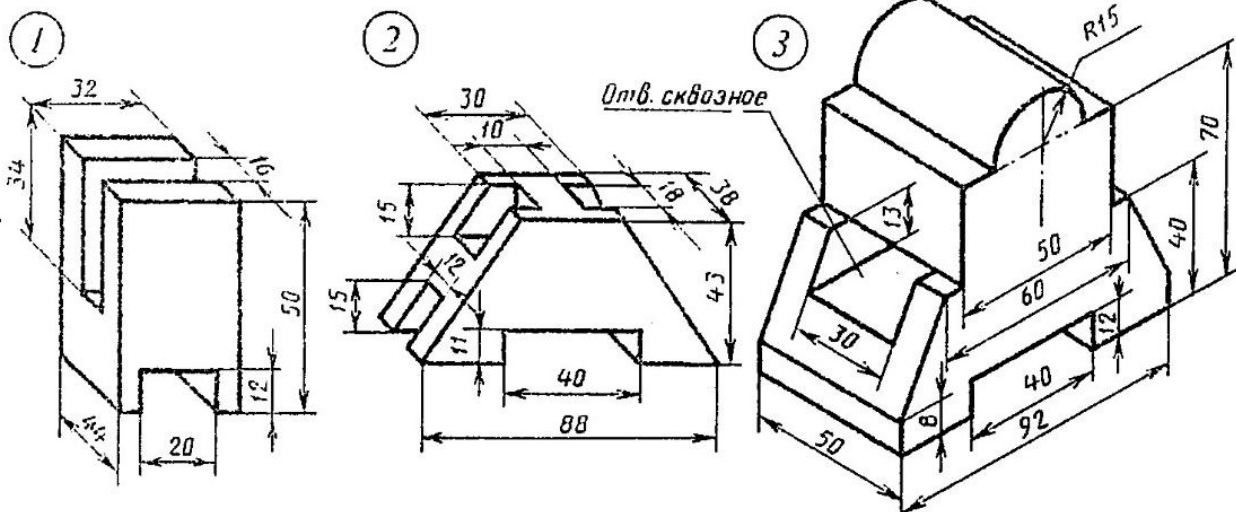

Вариант 14

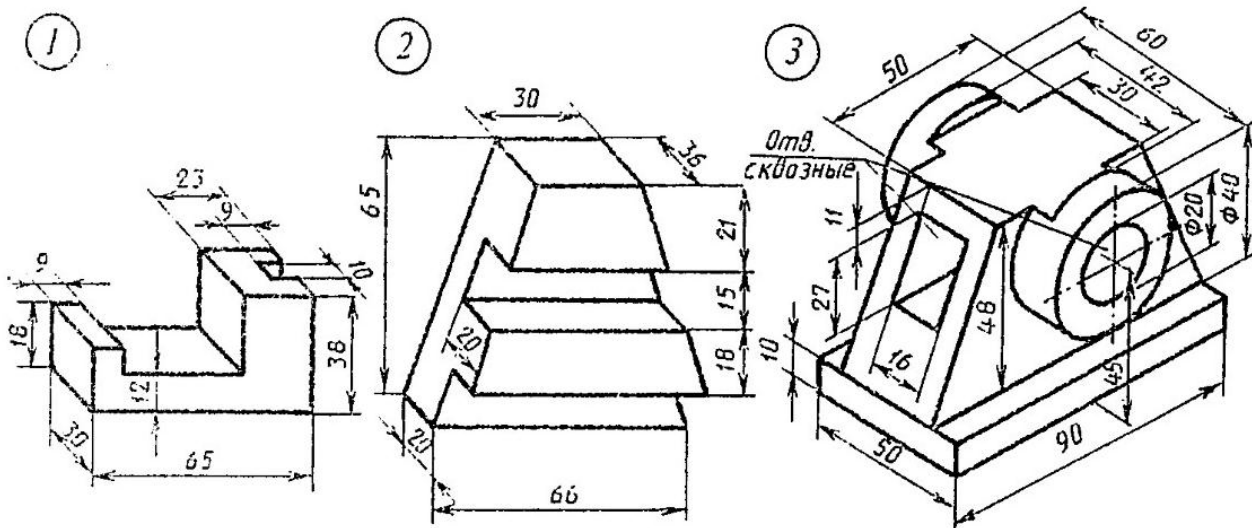

Вариант 15

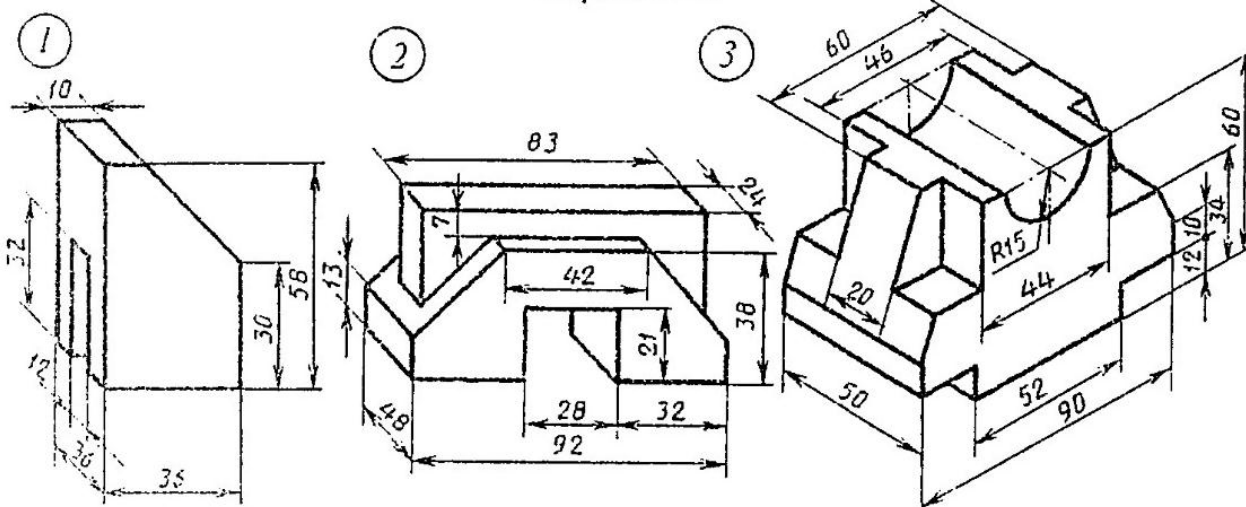

Вариант 16

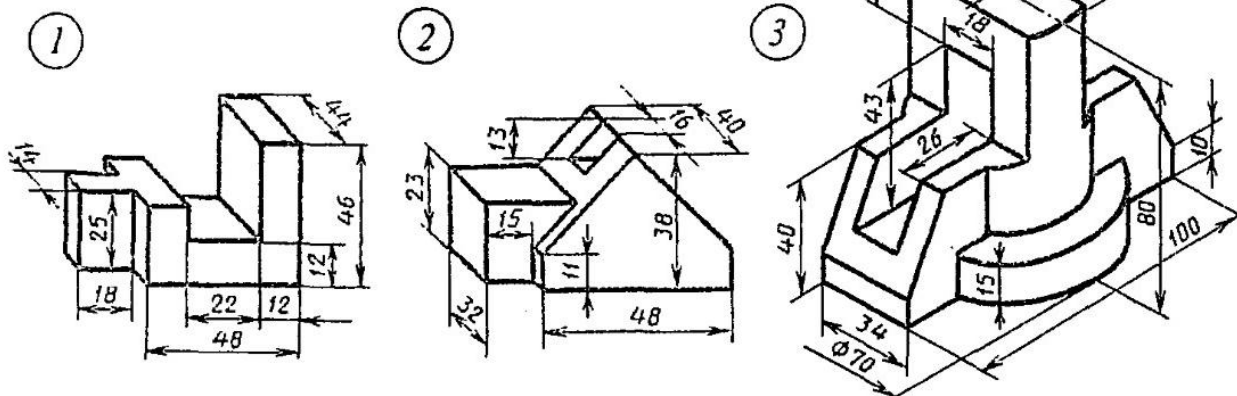

Вариант 17

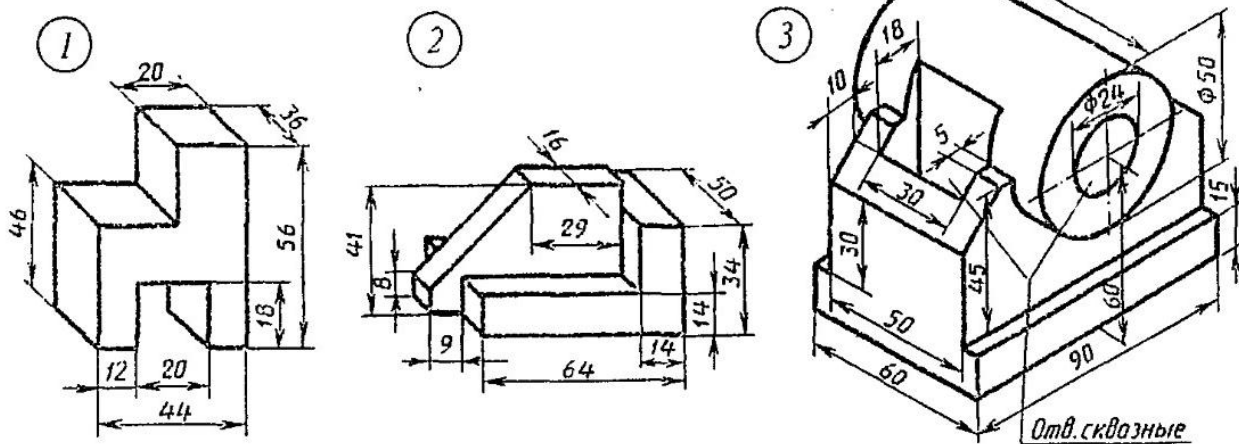

Вариант 18

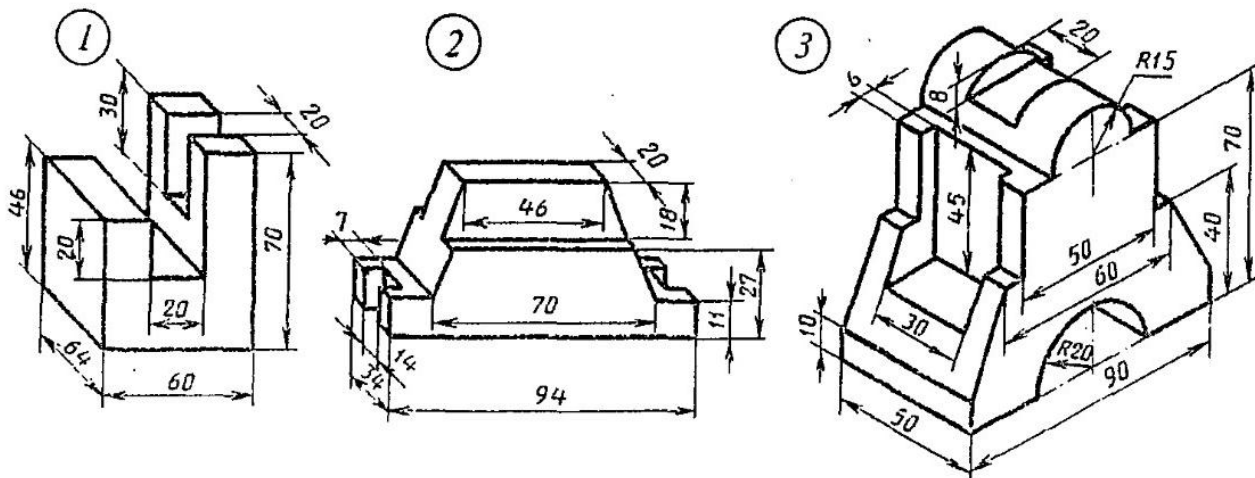

Вариант 19

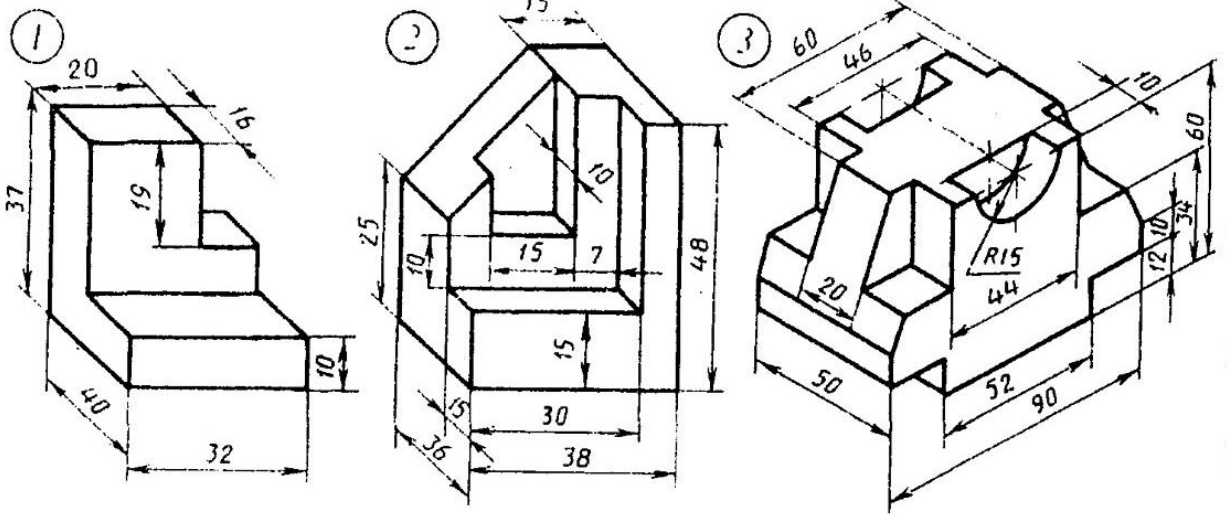

Вариант 20

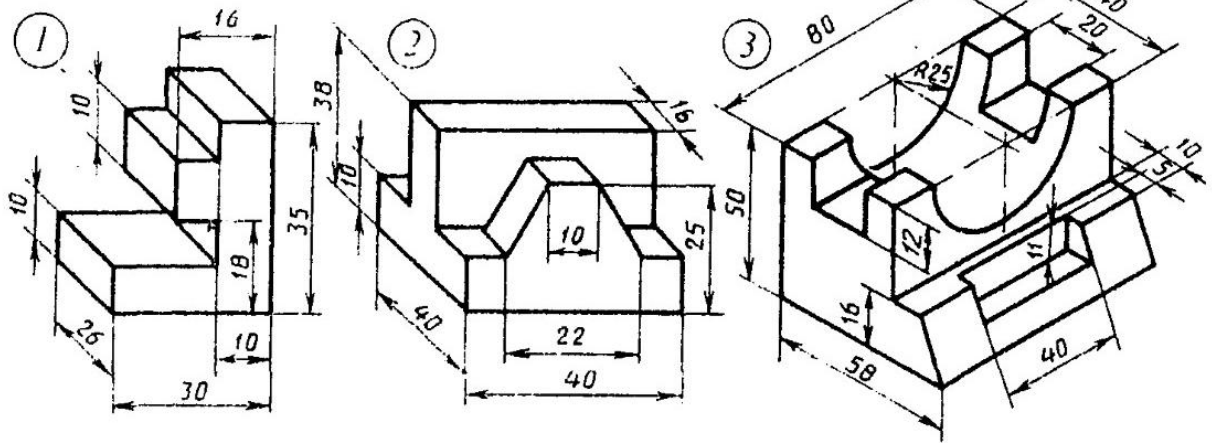

Вариант 21

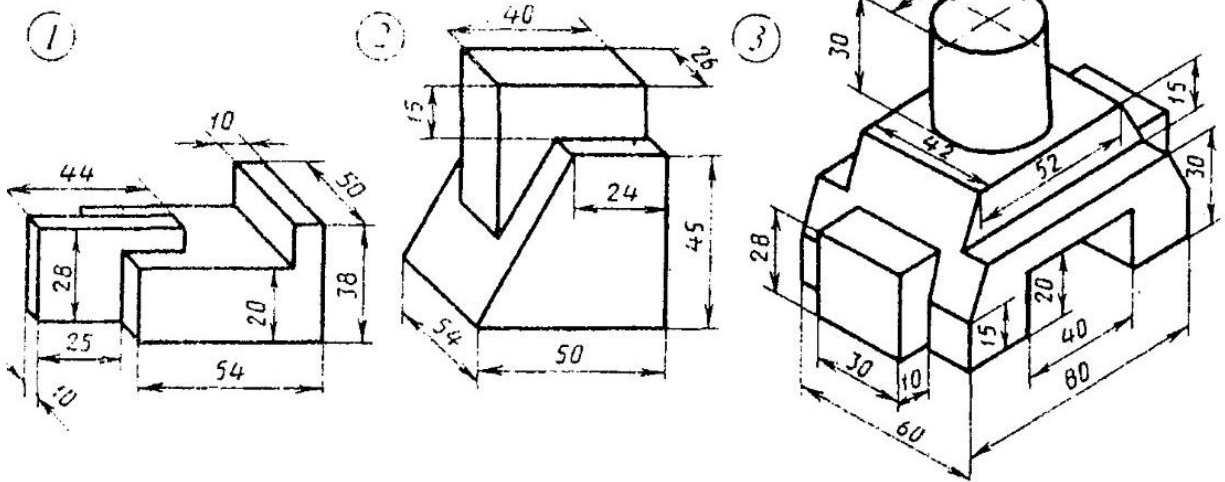

Вариант 22

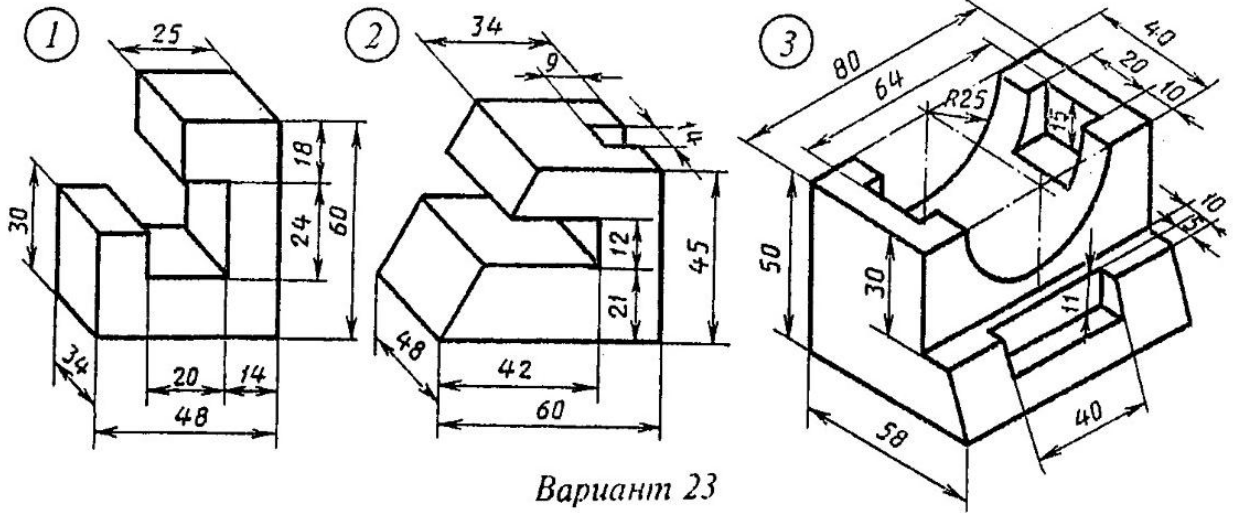

Вариант 23

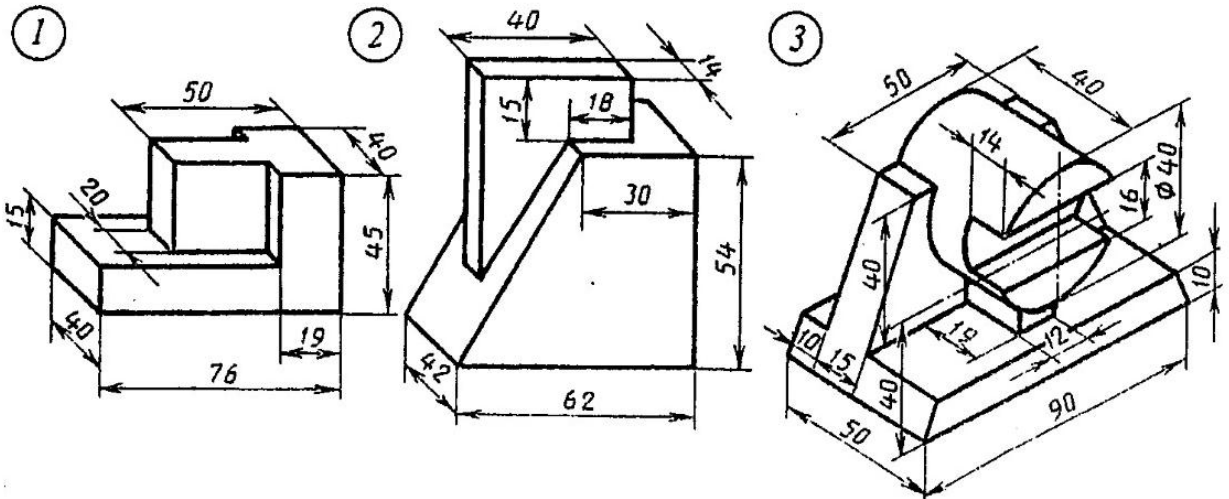

Вариант 24

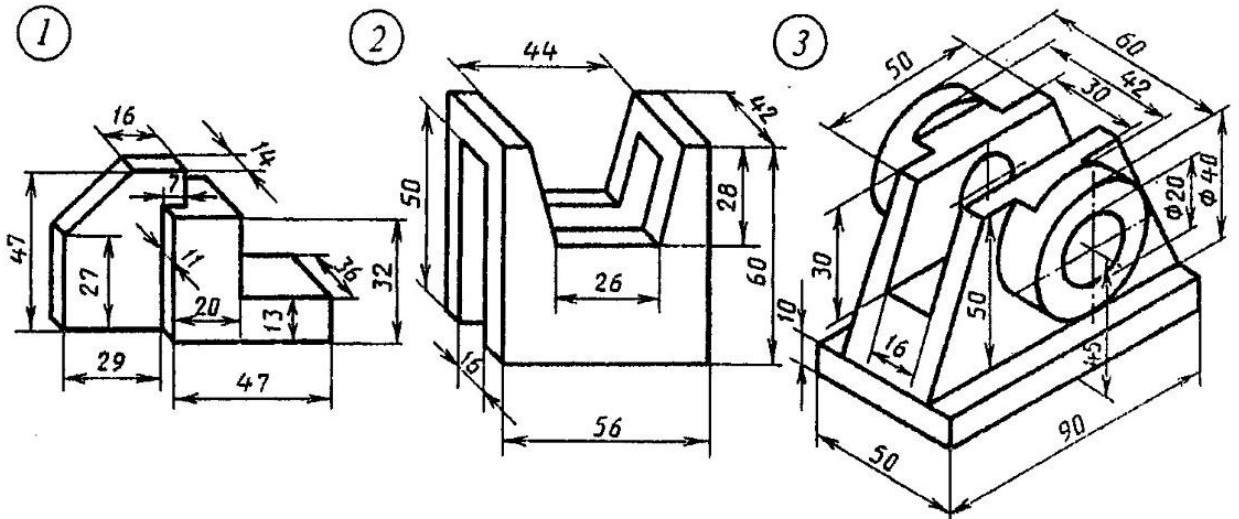

Вариант 25

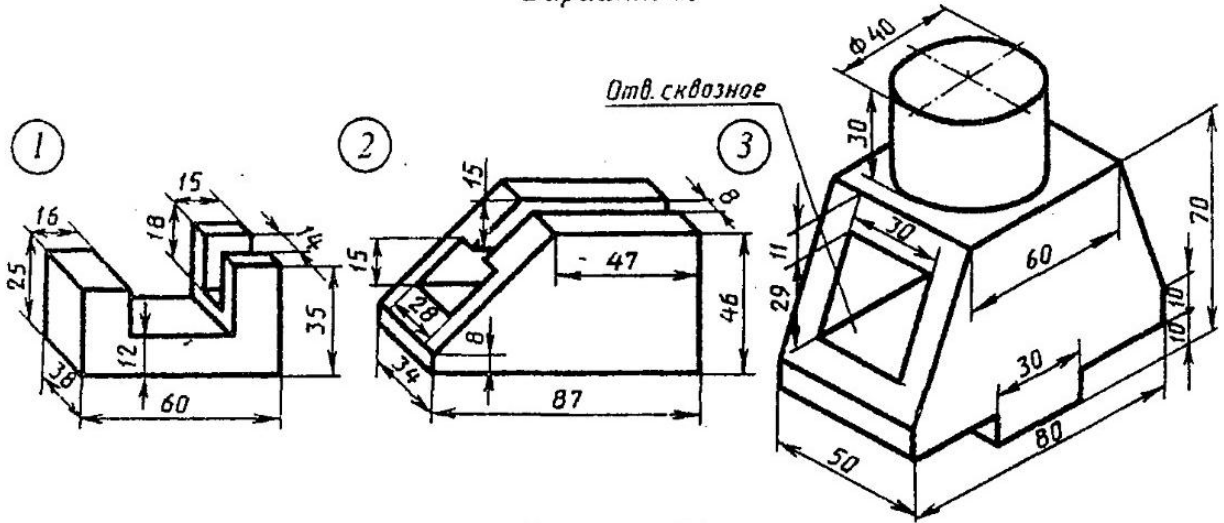

Вариант 26

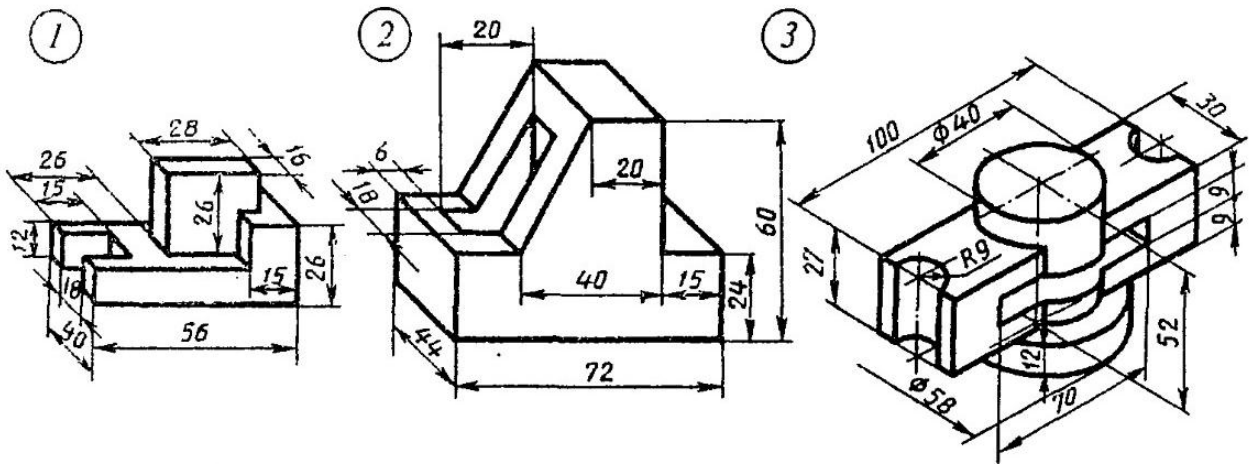

Вариант 27

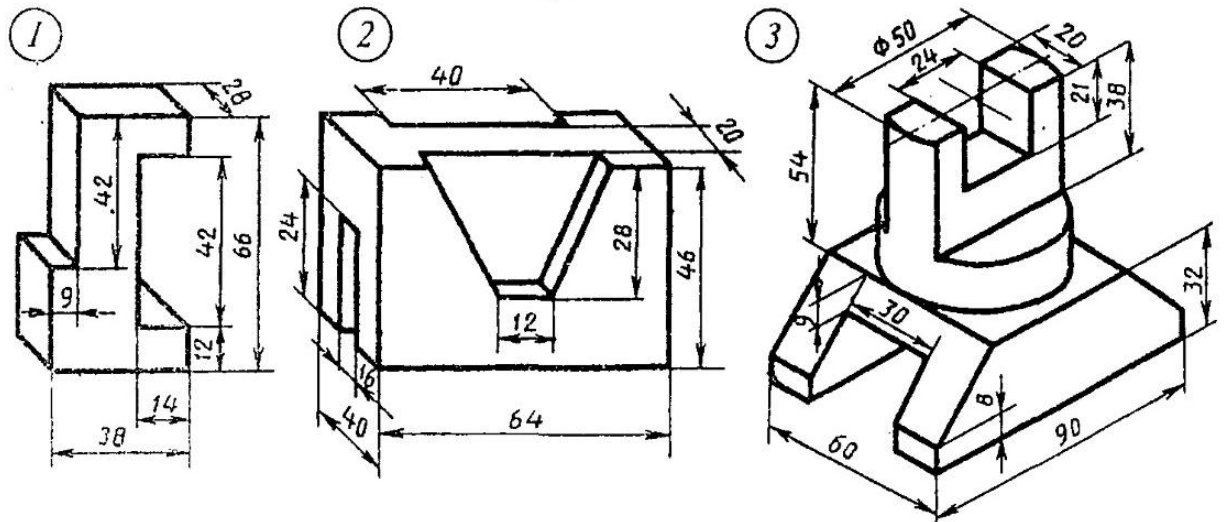

Вариант 28

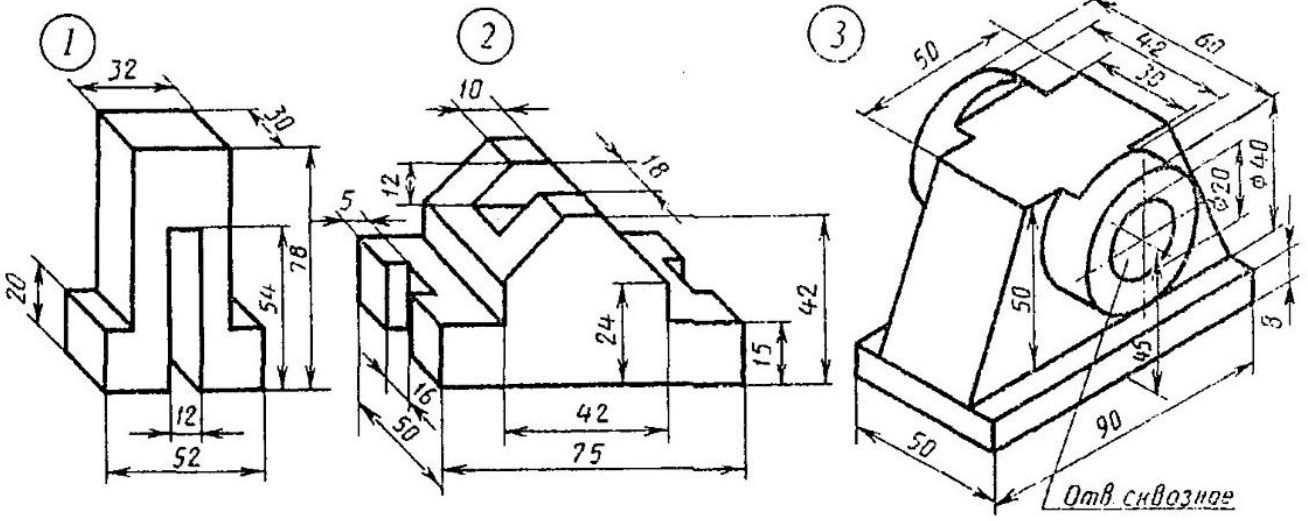

Вариант 29

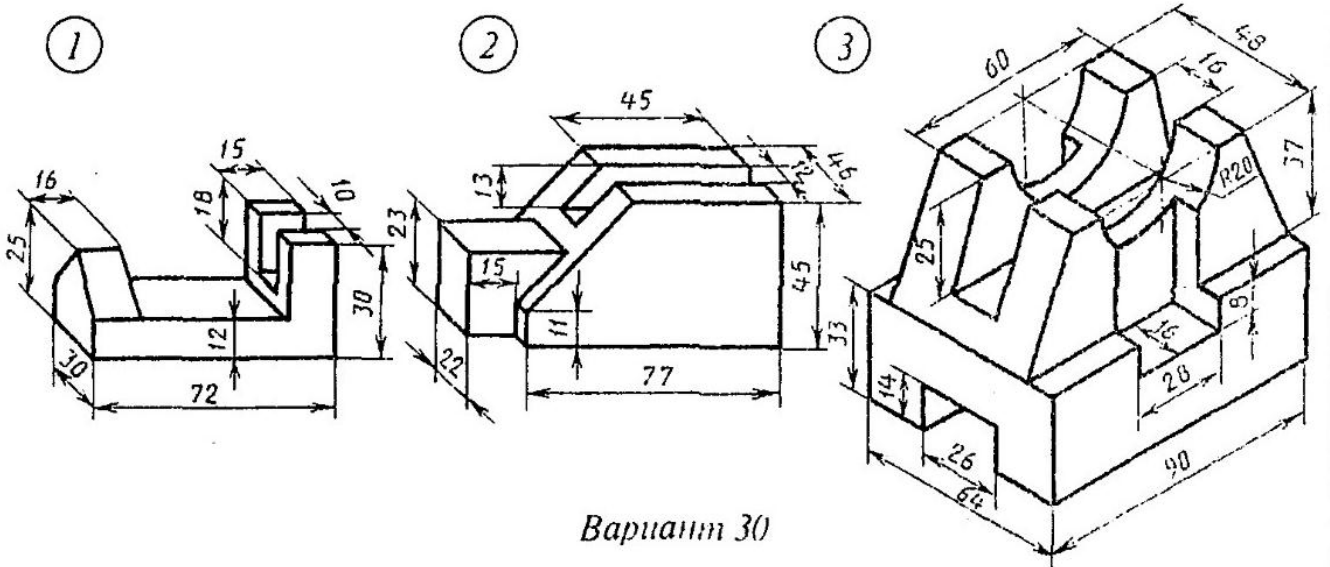

Вариант 30

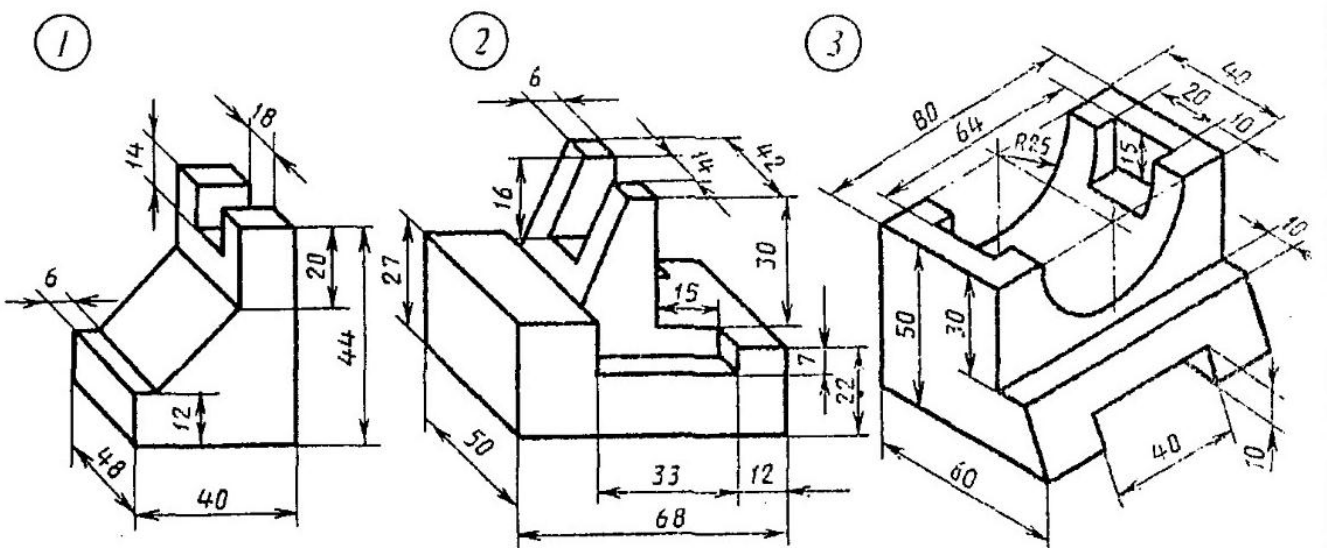

MAVZU №8: AUTOCAD DA 3D OB'EKTLARNI TAHRIRLASH, LOYIHANI RASMIYLASHTIRISH VA PRINTERDA CHOP ETISH

Geometrik modellashtirish uchun elementar geometriya, chizma geometriya qoidalarini bilish talab etiladi. Geometrik modellashtirish elementlari nuqta, chiziq (to'g'ri chiziq), sirt (tekislik)dir. Shu o'rinda ushbu elementlarning uzviy bog'liqligini unutmaslik lozim. Ya'ni:

Har qanday sirt chiziqlar to'plamidan iborat, chiziqlar esa nuqtalar to'plamidan tashkil topadi. Demak sirtni nuqtalar to'plamidan iborat deb qarash mumkin.

Chiziqni xususiy holi to'g'ri chiziqdir, kesma to'g'ri chiziqning bir bo'lagi. Har qanday to'g'ri chiziqdan kesma ajratib olish mumkin, har qanday kesma orqali cheksizlikka yo'naltirilgan bitta to'g'ri chiziq o'tkazish mumkin.

Har qanday sirtni yasovchilari va yo'naltiruvchilari mavjud. Tekislik yasovchisi va yo'naltiruvchisi to'g'ri chiziqlardan iborat sirtidir. Har qanday sirtga tegishli nuqta shu sirtga tegishli bo'lgan chiziqqa tegishli bo'ladi.

Geometrik modellashtirishda qabul qilingan standart qoidalari – O'zDST talablarini bilish modelni to'g'ri o'qishni va hammabopligini ta'minlaydi. Ya'ni:

Modellashtirish uchun format tanlash O'zDST 2.301-96 (Formatlar)ga asosan;

Modelni formatga joylashtirish O'zDST 2.302-97 (Masshtablar)ga asosan;

Modelda chiziq turlari O'zDST 2.303-97 (CHizma chiziqlari) ga asosan;

Modeldagi yozma axborotlar O'zDST 2.304-97 (SHriflar), O'zDST 2.104-68 (Asosiy yozuv) ga asosan;

Model ko'rinishlari soni va ularni proeksion bog'lanishi O'zDST 2.305-97 (Ko'rinishlar, qirqimlar, kesimlar) ga asosan;

Modelning geometrik axborotlari O'zDST 2.307-96 (O'lcham qo'yish qoidalari) ga asosan bajarilishi zarur.

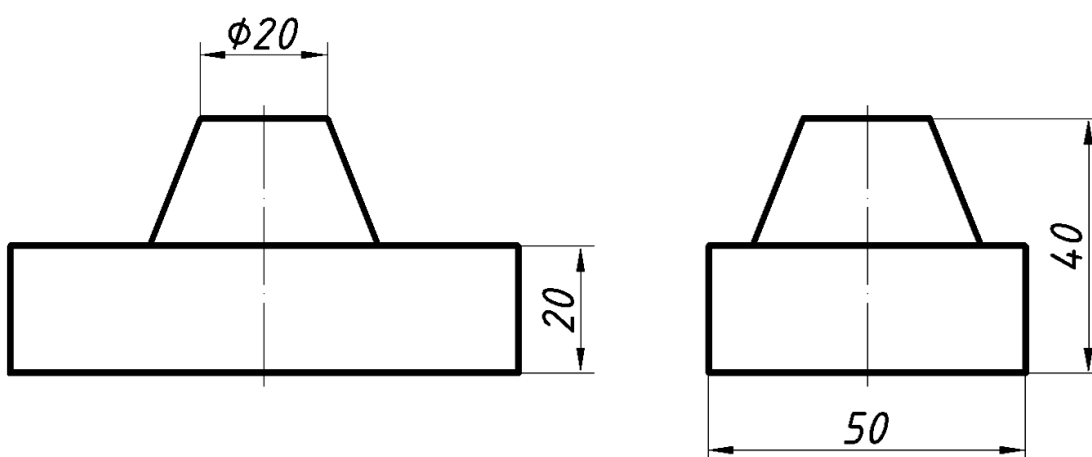

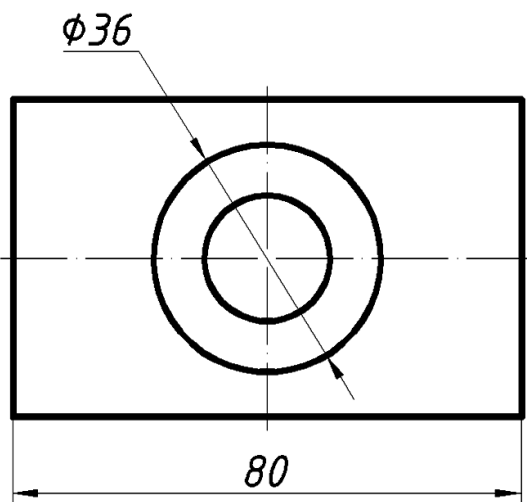

Ortogonal proeksiyalash usuliga asoslangan geometrik modellashtirish apparati va O'zDST talablari asosida bajarilgan model original ob'ekt ma'lumotlarini o'zida mujassamlashtiradi va unga tenglashtiriladi.

Bugungi kunda geometrik modellashtirishga bo'lgan asosiy ehtiyoj shundan iboratki kompyuterda turli hodisa va jarayonlarni modellashtirish uchun fazoviy ob'ektlarning geometrik modellari zarur. O'ch o'lchamli geometrik modellarga to'rtinchi, beshinchi, oltinchi va h. parametrlarni bergan holda murakkab muhandislik masalalarning maqbul echimlarini topish mumkin.

Bunday modellashtirish kompyuterda modellashtirish deyiladi

Konstruktorlik xujjatlarining turlari.

Konstruktorlik xujjatlariga GOST 2.102-60 ga muvofiq, grafikaviy va tekstli xujjatlar kiradi. Bu xujjatlar ayrim yoki yig'ilgan holda buyumning tarkibi va tuzilishi, uni tuzish yoki tayyorlash, shuningdek, nazorat, qabul qilish, ishlatish va remont qilish uchun zarur ma'lumotlarni o'z ichiga oladi.

Qo'yida konstruktorlik xujjatlarning ayrimlariga tushuncha berib utamiz.

Detal chizmasi – detalning tasviri hamda detalni tayirlash va nazorat qilish uchun zarur bo'lgan ma'lumotlarni o'z ichiga olgan xujjat.

Yig'ish chizmasi – buyumning tasviri hamda buyumni tayyorlash, yig'ish va nazorat qilish uchun zarur bo'lgan ma'lumotlarni o'z ichiga olgan xujjat. SHuningdek, yig'ish chizmalari qatoriga gidromontaj, pnevmomontaj, elektromontaj va sho'nga o'xshash chizmalarni ham kiritish mumkin.

Umumiy ko'rinish chizmasi - buyumning Konstruksiyasini, uning asosiy tarkibiy qismlarining o'zaro bog'lanishini va buning ishlash prinsipini aniqlovchi xujjat.

Nazariy chizma – buyumning geometrik shakli va tarkibiy qismlarini aniqlovchi xujjat.

Gabarit chizma – buyumning kontur (soddalashtirilgan) tasviri va uning gabarit, o'rnatish va biriktirish o'lchamlari keltirilgan xujjat.

Montaj chizma – buyumning kontur tasviri, shuningdek, uning montaji (urnatish) uchun zarur ma'lumotlarga ega bo'lgan xujjat.

Montaj chizmalariga buyumni o'rnatish uchun alohida tuzilgan poydevor chizmalarini ham kiritish mumkin.

Sxema – buyumning yoki uning qismlarini va ularning o‘zaro bog‘lanishining shartli ravishda tasviri ko‘rsatilgan xujjat.

Spetsifikatsiya – yig‘ma birlik, komplekt va komplekslarning tarkibini aniqlovchi xujjat.

Konstruktorlik xujjatlari loyihalash darajasiga qarab, *loyixa* va *ish* xujjatlariga bo‘linadi.

Loyixa xujjatlariga texnikaviy takliflar, eskiz va loyi-xalar kiradi, ish xujjatlariga esa buyumlar va ularning tarkibiy qismlarini ishlab chiqarish, nazorat qilish, ishlatish va remont qilish uchun zarur bo‘lgan ish xujjatlari kiradi.

Konstruktorlik xujjatlari bajarish usuliga qarab qo‘yidagi turlarga bo‘linadi.

1. **Originallar** – istalgan materialda bajarilgan xujjatlar bo‘lib, ular asl tayyorlash uchun mo‘ljallangan.

2. **Asl nusxalar**–ko‘plab nusxa ko‘chirish imkoniyatini beradigan materialda bajarilgan va mas‘ul shaxslarning asl imzolari bilan rasmiylashtirilgan xujjat.

Asl nusxa sifatida original, fotonusxa yoki bosmaxonada nashr qilingan va xujjatni chiqarish uchun mas‘uliyatli shaxslarning asl imzolari bilan rasmiylashtirilgan xujjatlardan foydalanishga yo‘l qo‘yiladi.

Dublikatlar – asl nusxalardan olingan nusxalar bo‘lib, asl nusxalar bilan bir xillikni saqlab, asl nusxalarni qayta tiklash va nusxalar ko‘chirish imkoniyatini beradigan istalgan materialda bajarilgan xujjat.

Nusxalar – asl nusxa yoki dublikat bilan bir xillikni saqlab qolish usuli bilan bajarilgan xujjat bo‘lib, buyumni loyixalashda, ishlab chiqarishda ishlatilish va remont qilishda bevosita foydalanish uchun mo‘ljallanadi.

Ishlab chiqarish bir marta foydalanish uchun ko‘zda tutilgan xujjatlarni konstruktorlik eskiz xujjatlarni ko‘rinishda bajarishga yul qo‘yiladi.

SHuningdek, yig‘ma birliklar qatoriga qo‘yidagi buyumlarni ham kiritish mumkin:

2. Konstruksiyasi bo‘yicha tayyorlovchi korxonalarda upakovka joylashtirish yoki transportirovka qilish maksadida, tarkibiy qismlarga ajratilgan buyumlar, masalan, minorali kranlar, ekskavatorlar, po‘lat konstruksiyali ko‘p rliklar va boshqalar.

3. Umumiy vazifaga ega bo‘lgan yig‘ma birliklar va detallar to‘plamidan tashqil topgan buyumlar bo‘lib, ular tayyorlovchi korxonalarda boshqa yig‘ma birliklarga o‘rnatiladi. Masalan, avtomobil va traktorlarning elektr jixozlari, sovitish tizimi, yonilg‘i bilan ta‘minlash tizimi va shunga o‘xshashlar.....

4. Umumiy vazifaga ega bo‘lgan va tayyorlovchi korxonada joylashtiruvchi vositalarga (kuti, gilof va shunga o‘xshashlarga) qo‘yilgan bo‘lib, ulardan birgalikda foydalanish ko‘zda tutiladi, masalan, gotovalnaya, o‘lchash asboblari, ko‘chirma asbob-uskunalar komplektlari va boshqalar.

Kompleks - ikki va undan ortik maxsuslashtirilgan buyumlar tayyorlovchi korxonada yig‘ish operatsiyalari bilan birlashtiril-magan, ammo o‘zaro bir-biriga bog‘liq ekspluatatsion funksiyalarni bajarish ko‘zda tutilgan buyumlar. Kompleksga kiruvchi har bir buyum kompleks uchun bir yoki bir necha asosiy funksiyalarni bajarishga xizmat qiladi.

Kompleksga stanoklarning potok liniyalari, parmalash qurilmalari, paxta terish mashinalari va shunga o‘xshashlar misol bo‘lishi mumkin.

Kompleksga asosiy funksiyalarni bajaruvchi buyumlardan tashqari yordamchi funksiyalarni bajaruvchi detallar, yig‘ma birliklar ham kirishi mumkin, masalan,

kompleksni o'rganish uchun mo'ljallangan detallar, yig'ma birliklar, extiyoriy qismlar komplekti va shunga o'xshashlar.

Komplekt - tayyorlovchi korxonada yig'ish operatsiyalari bilan biriktirilmagan, umumiy yordamchi harakterdagi vazifalarga ega bo'lgan ikki va undan ortiq bo'lgan buyumlar.

Komplektga extiyot qismlar komplekti, asboblar va jixozlar, ulchash apparatlari komplekti va boshqalar kiradi.

SHuningdek, komplektga yig'ma birliklar va detallar bilan qo'shib jo'natiladigan, ekspluatatsiya qilishda yig'ma birliklar va detallarni ham kiritish mumkin.

Buyumlar tarkibiy qismlari bo'lishi yoki bo'lmasligi qarab ikkiga bo'linadi:

- 1) Spetsifikatsiyalangan (detaillar) – tarkibiy qismlarga ega bo'lmagan;
- 2) Spetsifikatsiyalangan (yig'ma birliklar, komplekslar, komplektlar) – ikki va undan ortiq qismlardan tashkil topgan buyumlar.

SHuni eslatib o'tish kerakki, tarkibiy qism har qanday buyum, masalan, detal, yig'ma birlik, kompleks va komplekt bo'lishi mumkin.

Sotib olinadigan buyumlarga mazkur korxonada tayyorlangan, tayyor holda (hamkorlik tariqasida etkazib beriladigaglardan tashqari) olinadigan buyumlar kiradi.

Topshiriqlarni bajarish tartibi

Payvandlangan buyumning yig'ma chizmasini bajarish

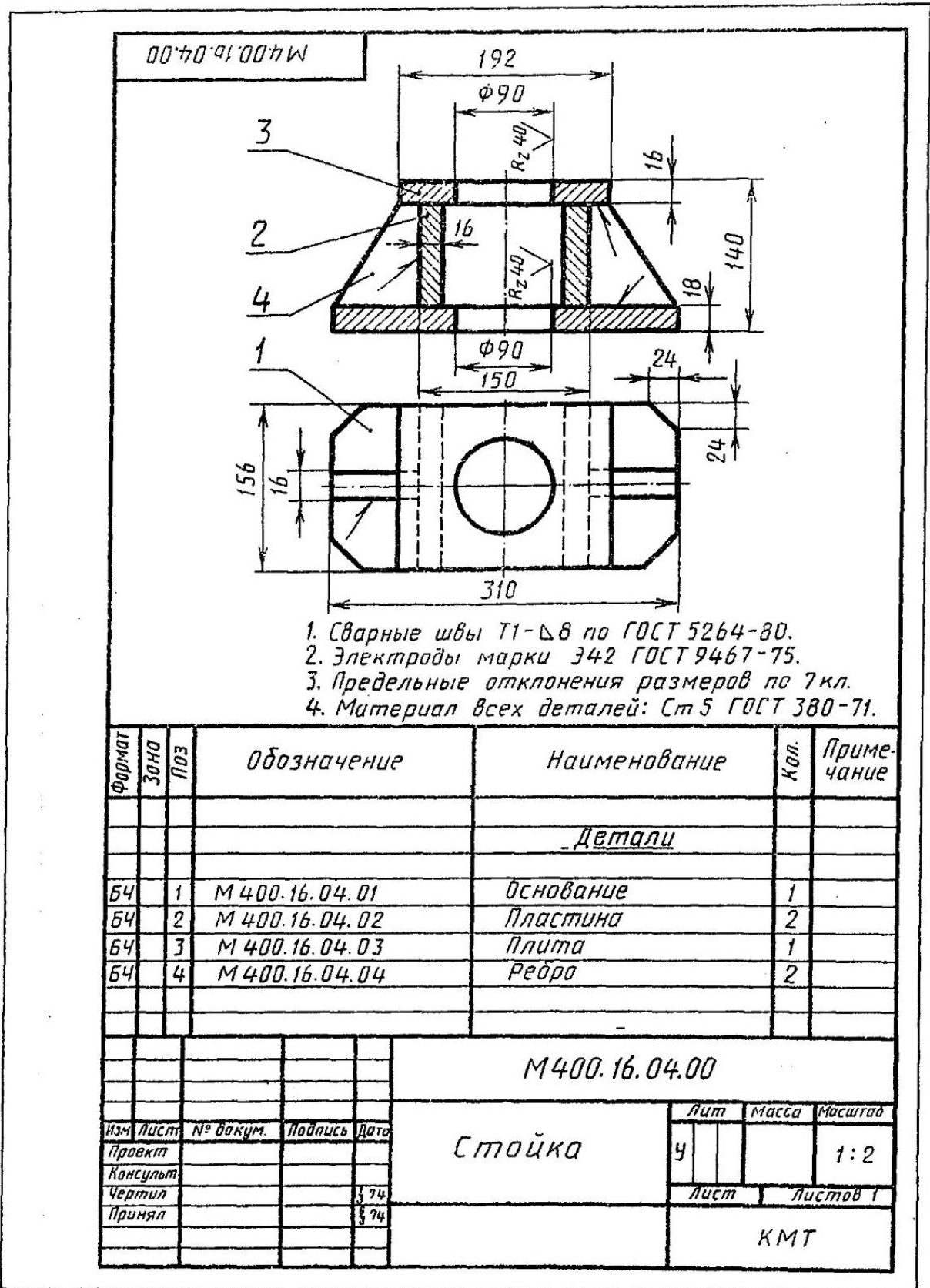

Вариант 1

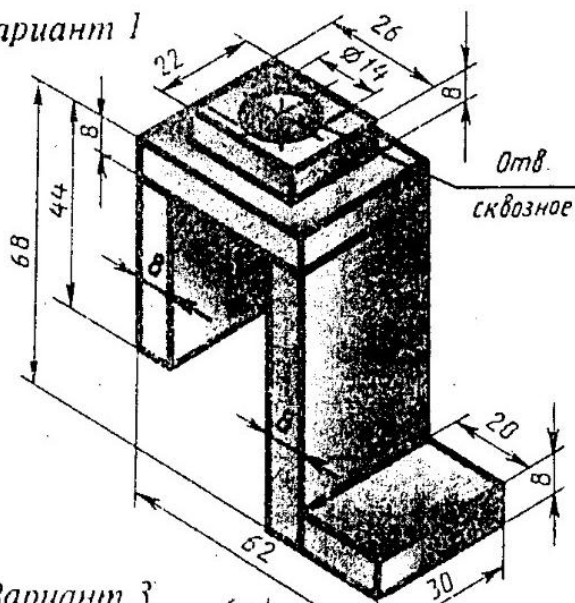

Вариант 2

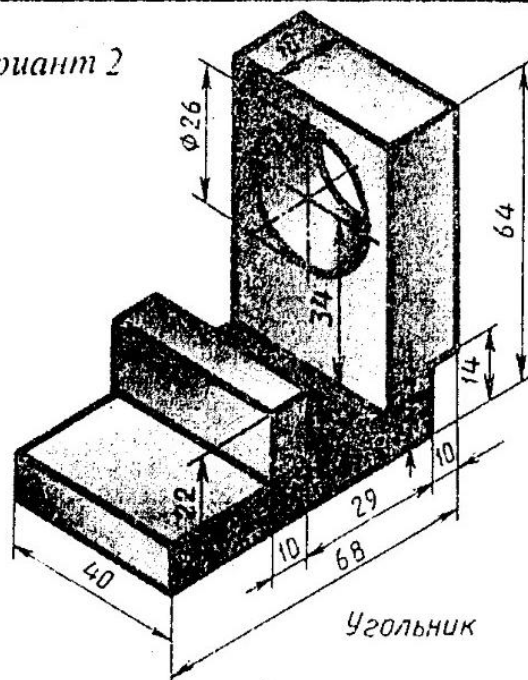

Вариант 3

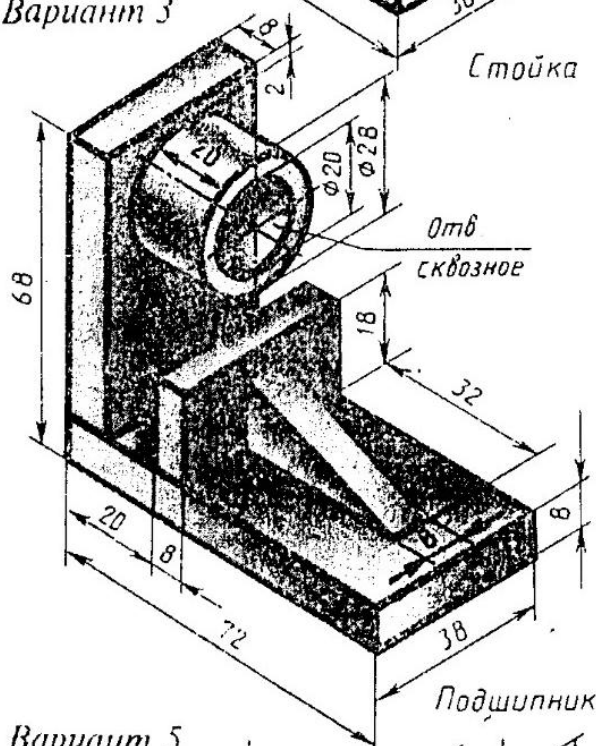

Вариант 4

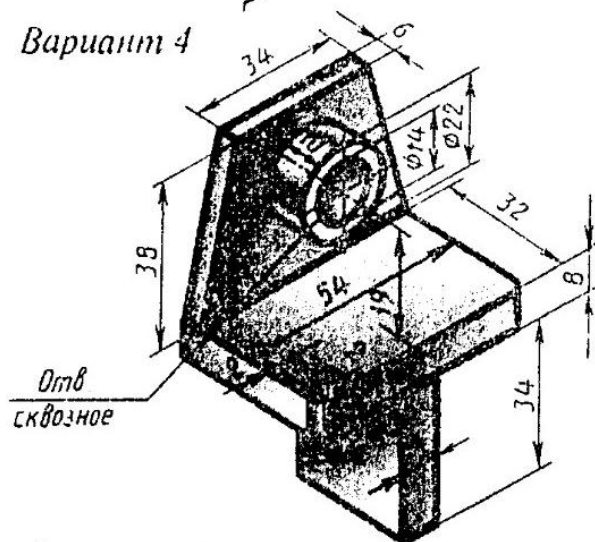

Вариант 6

Кронштейн

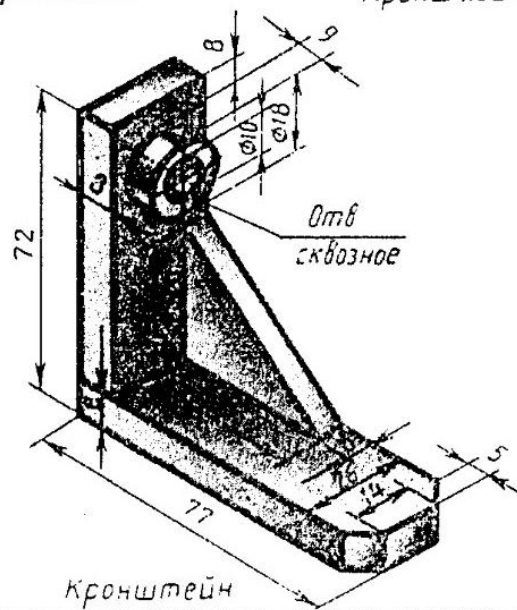

Вариант 5

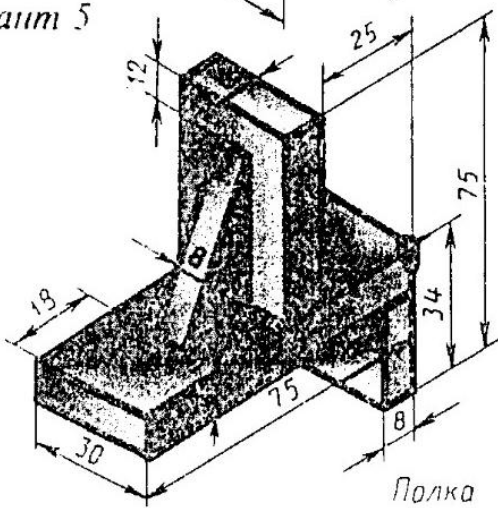

Вариант 7
Отв сквозное

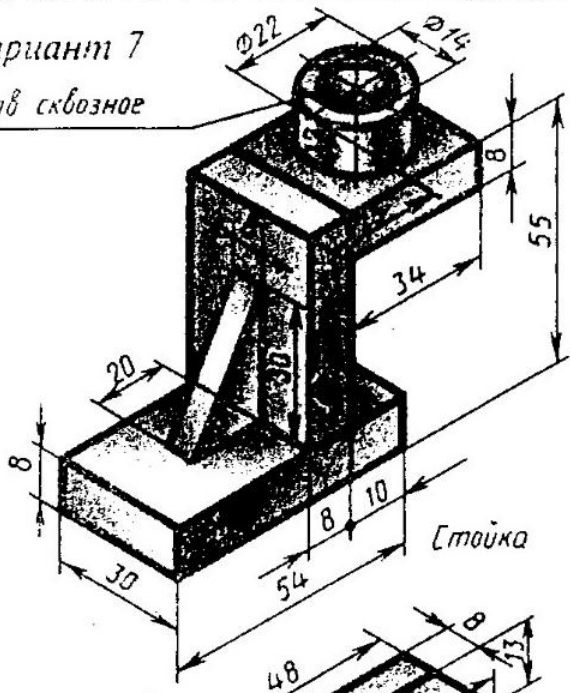

Вариант 8

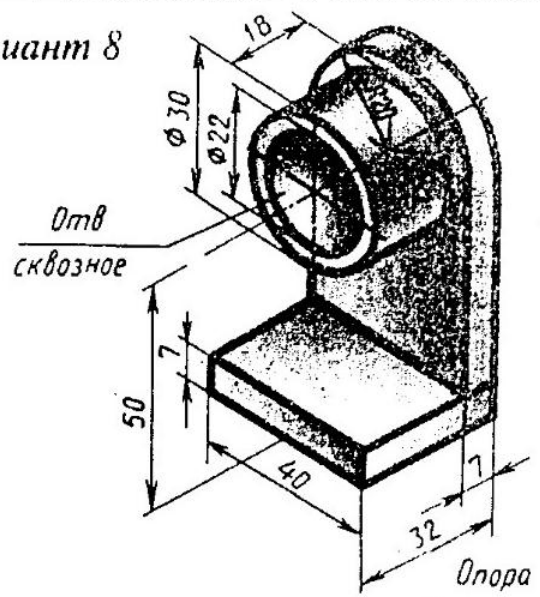

Вариант 9

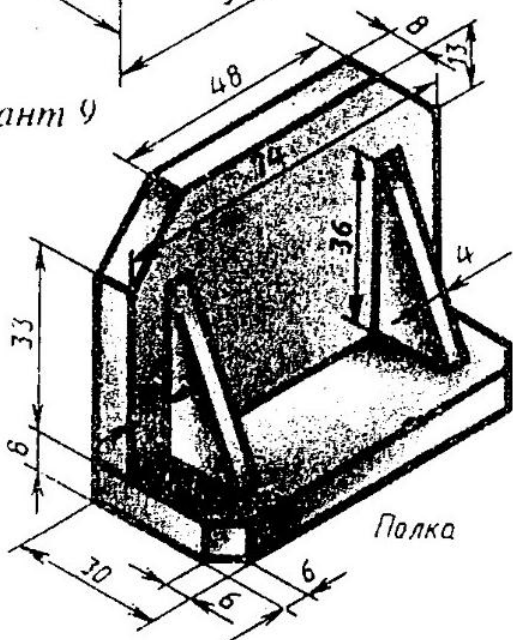

Вариант 10

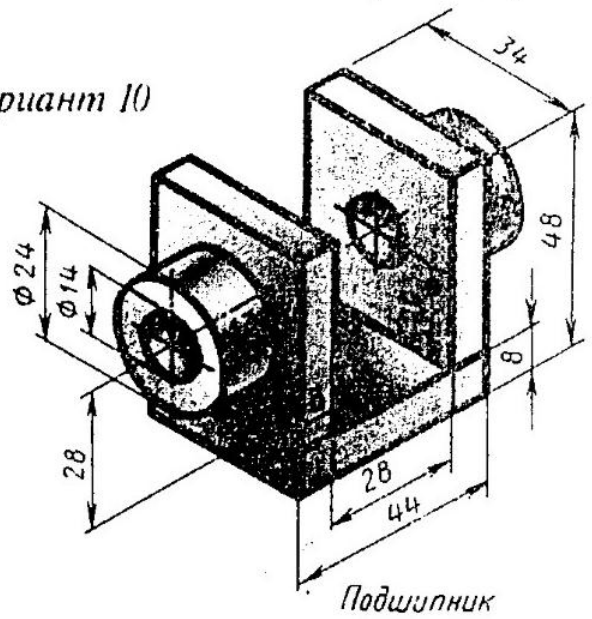

Вариант 11

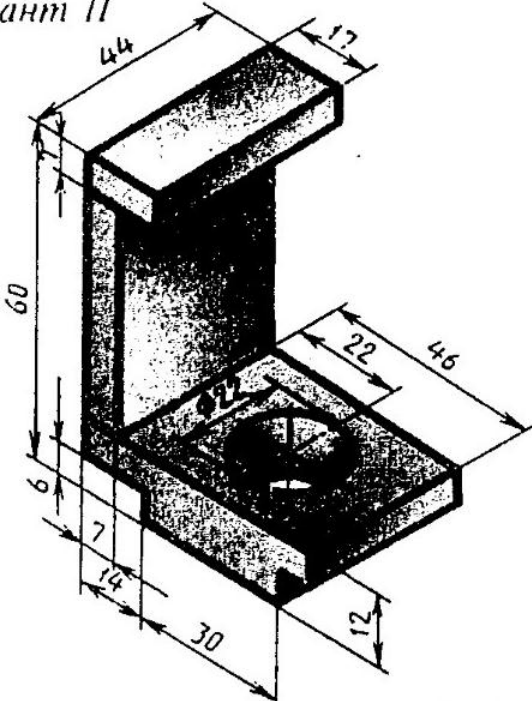

Вариант 12

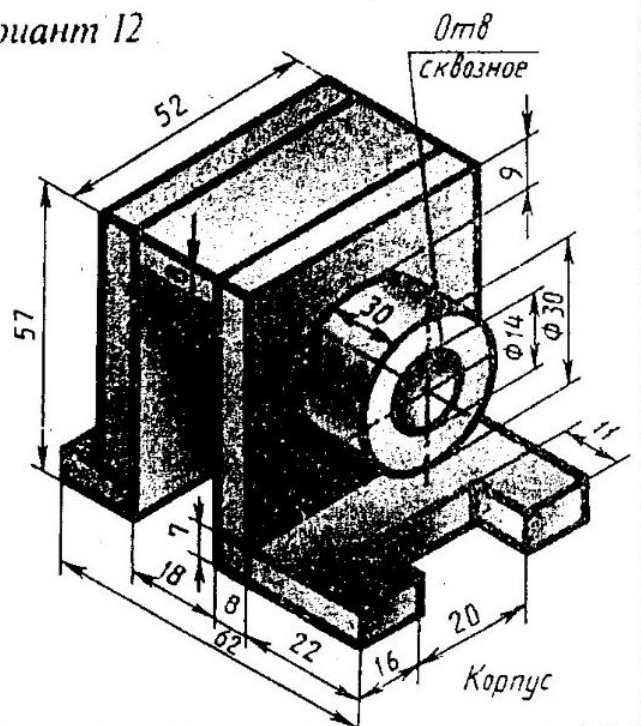

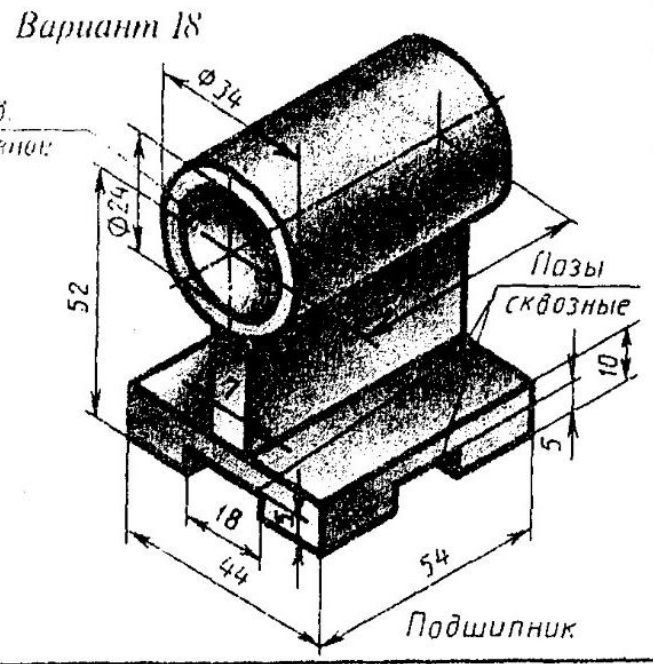
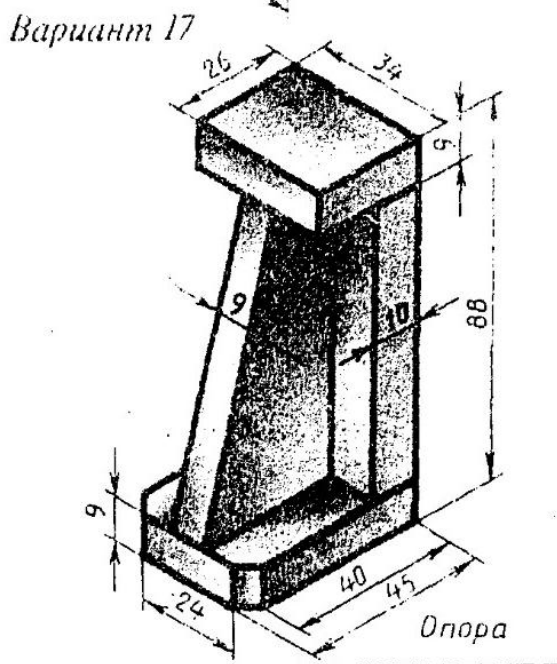
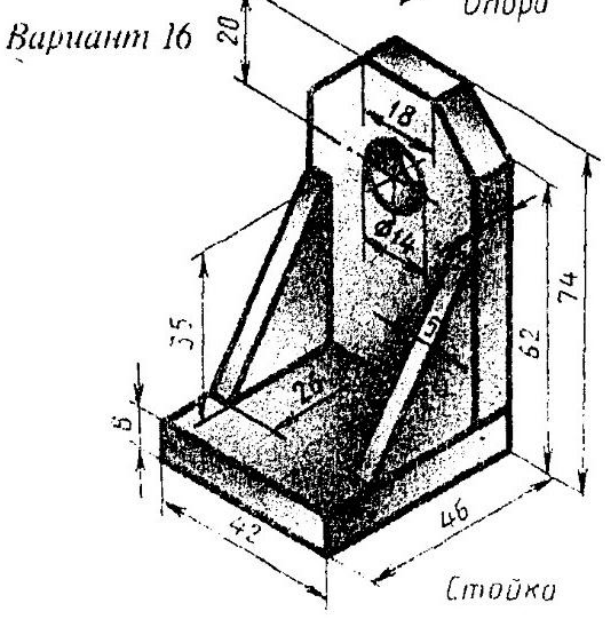
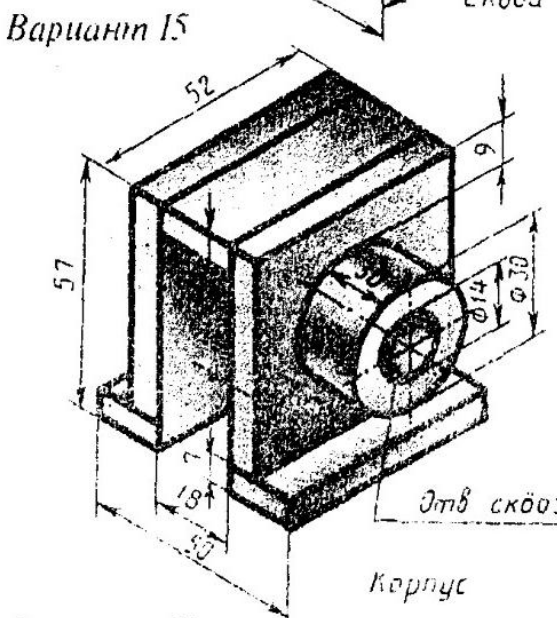
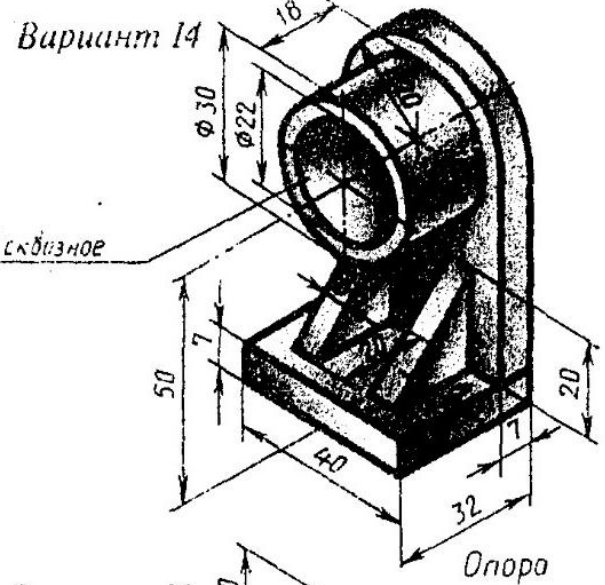
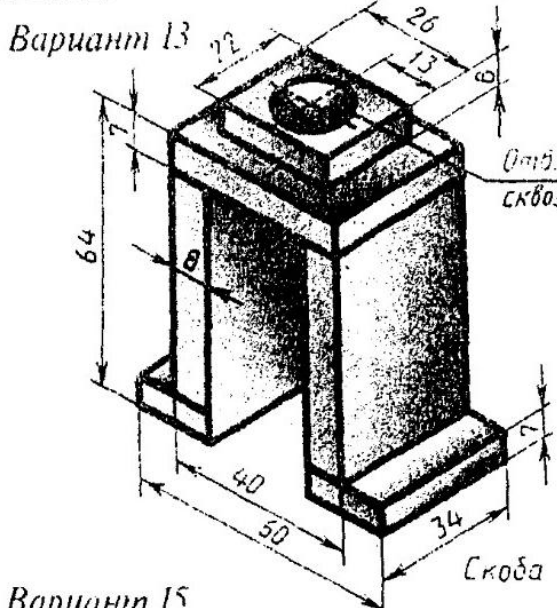

Вариант 19

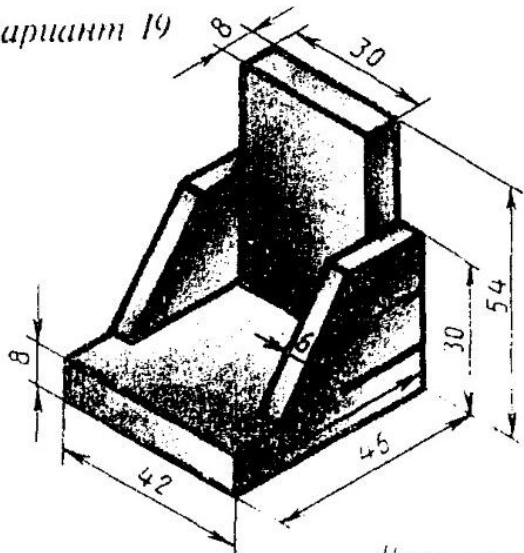

Угольник

Вариант 20

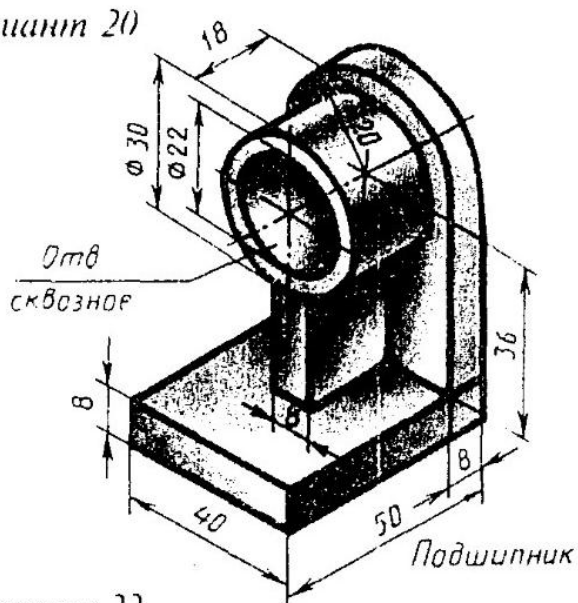

Подшипник

Вариант 21

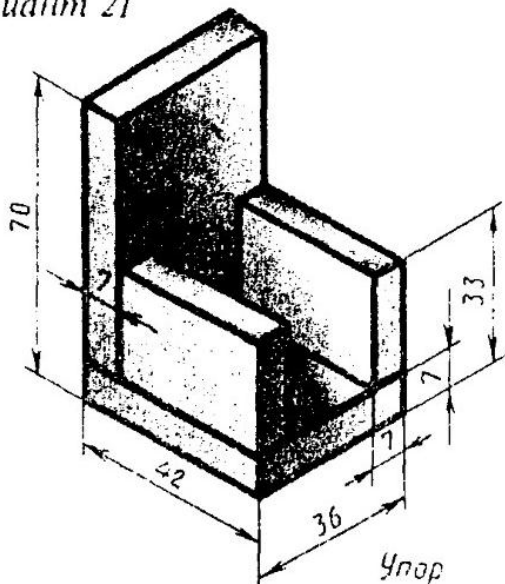

Упор

Вариант 22

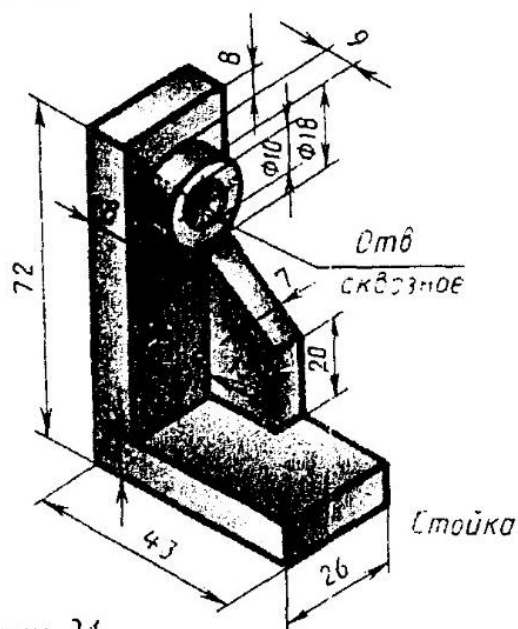

Стойка

Вариант 23

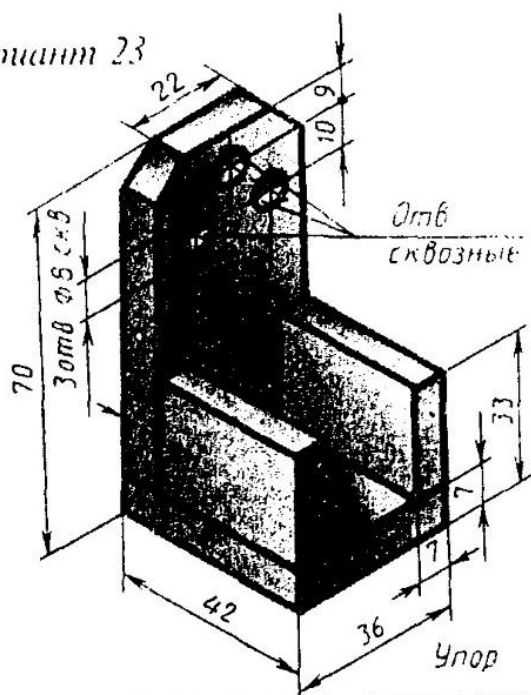

Упор

Вариант 24

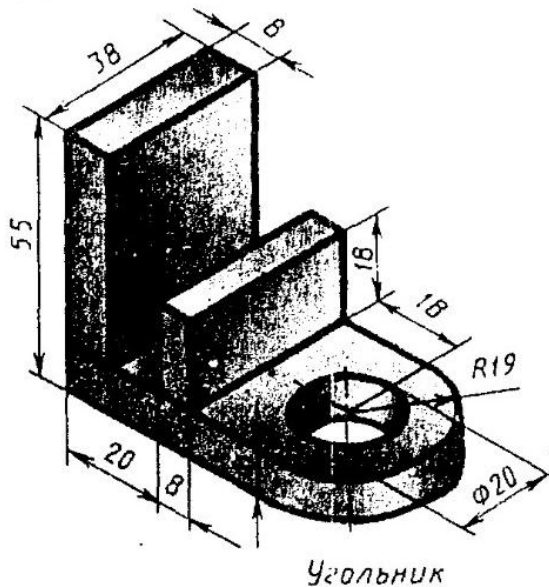

Угольник

Вариант 25

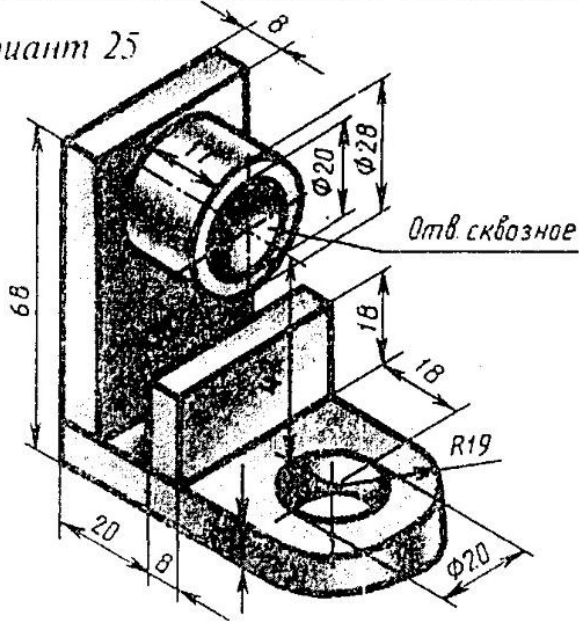

Вариант 26

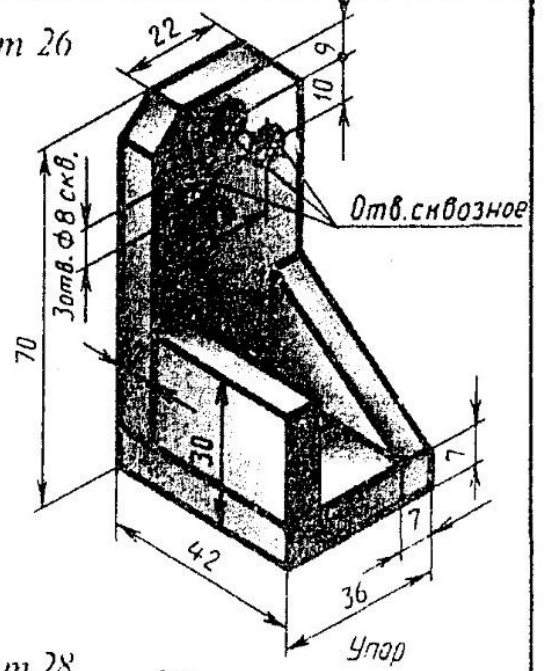

Вариант 27

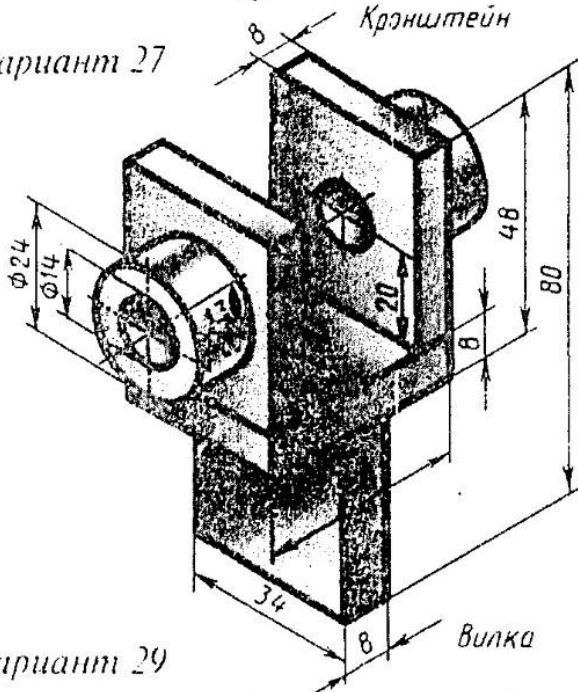

Вариант 28

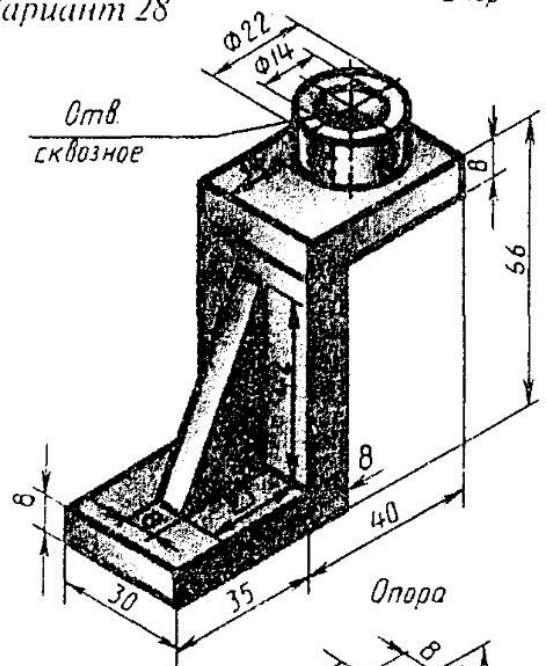

Вариант 29

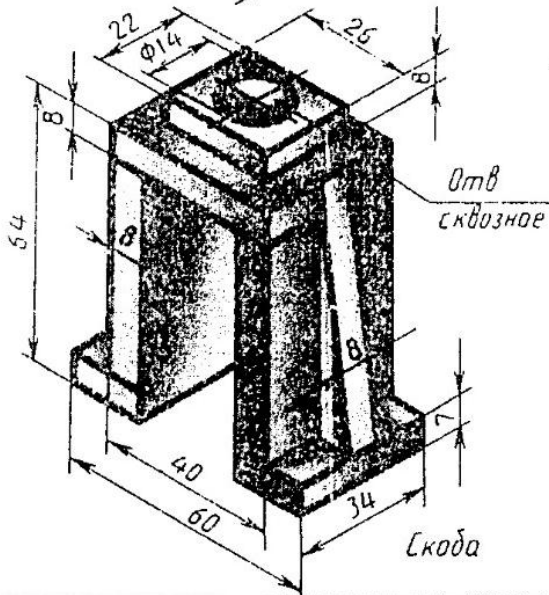

Вариант 30

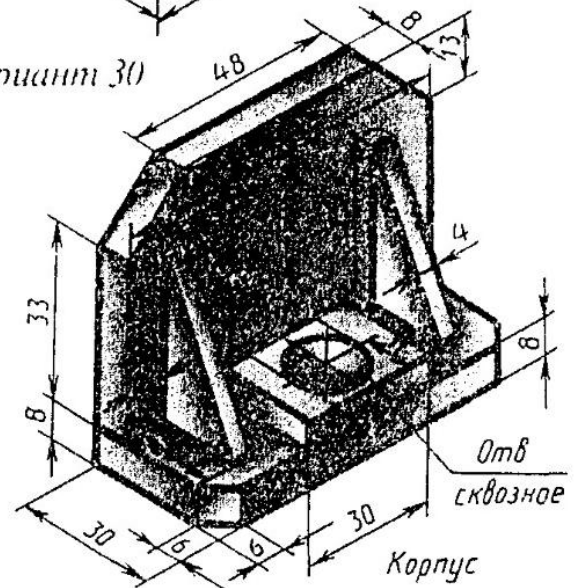

MUNDARIJA

5. PARAMETRIZATSIYA PANELI BILAN ISHLASH VA TASHQI OB'EKTLARNI YUKLASH	3
6. QATLAMLAR (СЛОИ).....	36
7. AUTOCAD DA UCH O'LCHAMLI TASVIRLAR – 3D TUSHUNCHASI VA SIRTLARNI HOSIL QILISH	42
8. AUTOCAD DA 3D OB'EKTLARNI TAHRIRLASH, LOYIHANI RASMIYLASHTIRISH VA PRINTERDA CHOP ETISH.....	60

ASOSIY ADABIYOTLAR

1. Rixsiboev T. Kompyuter grafikasi. – T: 2006

QO'SHIMCHA ADABIYOTLAR

1. Раян Д. Инженерная графика в САПР. – М: 1989
2. Рахмонкулова S.I. IBM PC shaxsiy kompyuterida ishlash. – T: 2002
3. Фролов С.Л. Начертательная геометрия. – М: Машиностроение, 1978
4. Боголюбов С.К. Индивидуальные задания по курсу черчение. – М: Высшая школа, 1989
5. Федоренков А., Кимаев А. AutoCAD 2002. – М.: 2001
6. Котсюбинский А.О. Рисунки на компьютере. – М.: 2000
7. Мураховский В.И. Компьютерная графика. – М., 2002
8. Дисален Д. AutoCAD программирование. – М.: 1992
9. Романичева Э.Т. и др. AutoCAD верс.12,13,14. – М.: 1997

INTERNET SAYTLARI

1. www.ziyo.net
2. www.twirpx.com
www.ing-grafika.ru/1/nachertatelnaya-geometriya.html
<http://antigtu.ru/976-lekcii-po-kompyuternoy-grafike.html>

